

# Unidrive M600 to M702 Size 3 & 4 UL Conduit Box Installation Sheet

## 1 Safety information



### Follow the instructions

The mechanical and electrical installation instructions must be adhered to. Any questions or doubt should be referred to the supplier of the equipment. It is the responsibility of the owner or user to ensure that the installation of the drive and any external option unit, and the way in which they are operated and maintained, comply with any applicable legislation, regulation, and code of practice in the country in which the equipment is used.



### Competence of the installer

The drive must be installed by qualified personnel who are familiar with the requirements for safety and EMC. The installer is responsible for ensuring that the end product or system complies with all the relevant laws in the country where it is to be used.

## 2 Introduction

This document covers the UL conduit box mounting instructions for Unidrive M600 to M702, frame size 3 & 4 drives and derivatives.

When fitted, the drive meets the requirement for Type 1 protection according to UL50 and UL50E.

Type 1 enclosures are intended for indoor use only. They provide a degree of protection to personnel against incidental contact with the enclosed equipment and a degree of protection against falling debris.

The following items are supplied in the kit:

Table 2-1 Contents of the kit (CT part number: 6521-0071)

Description	Image	Qty
Steel conduit plate		x 1
UL conduit box installation sheet		x 1

The installed conduit plate does not change the dimensions of the drive.

Table 2-2 shows the overall drive dimensions.

Table 2-2 Dimensions

Frame size	H		W		D	
	mm	in	mm	in	mm	in
3	365	14.4	83	3.3	200	7.9
4	365	14.4	124	4.9	200	7.9

## 3 Installation



### Stored charge

The drive contains capacitors that remain charged to a potentially lethal voltage after the AC and / or DC power supply has been disconnected. If the drive has been energized, the power supply must be isolated at least ten minutes before work may continue.

Normally, the capacitors are discharged by an internal resistor. Under certain, unusual fault conditions, it is possible that the capacitors may fail to discharge, or be prevented from being discharged by a voltage applied to the output terminals. If the drive has failed in a manner that causes the display to go blank immediately, it is possible the capacitors will not be discharged. In this case, consult Control Techniques or their authorized distributor.

Figure 3-1 Removing the drive terminal cover

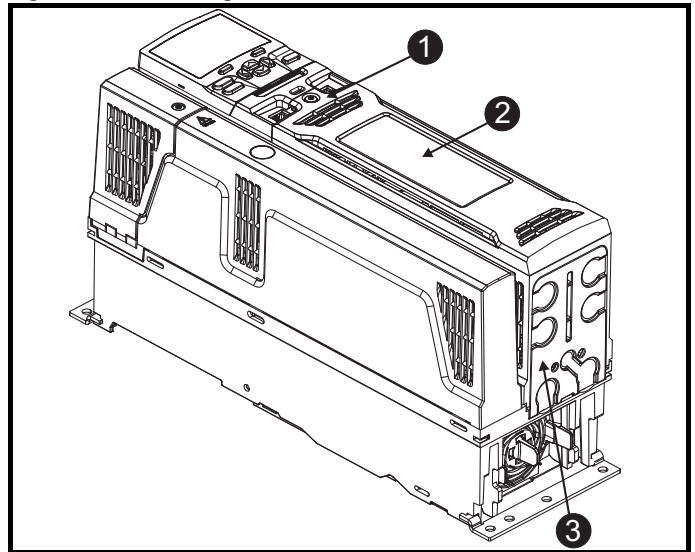

The removal process is the same for both the size 3 and size 4 drives.

- Unscrew (1) to remove the control pod cover (2) and the control finger guard (3).
- Unscrew the two M4 ground nuts and the M4 ground screw.



0478-0389-01

Figure 3-2 Installation of the conduit connection plate

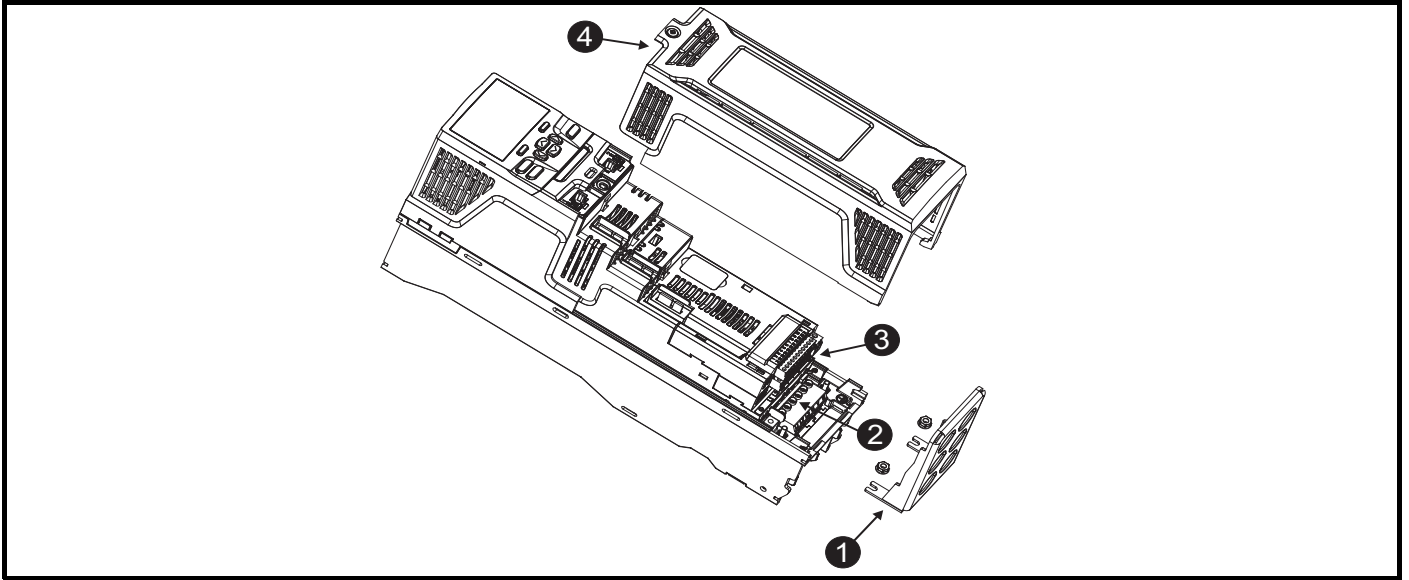

The installation process is the same for both the size 3 and size 4 drives.

- Remove the necessary knockouts on the control conduit plate (1) and then attach to the drive using the two M4 ground nuts. Recommended torque is 2 N m (18 lb in) (maximum torque is 2.5 N m (22 lb in)). Note: These two nut locations can still be used to ground cables and shields.
- Attach the conduit fittings to the conduit connection plate (1); run the conduit to the drive. Motor cables with motor ground wire, supply cables with supply ground wire, and control cables need to be run in separate conduits.
- Run the motor cables (U,V,W) and motor ground wire through the conduit. Connect the wires to the connector (U,V,W) (2). Recommended torque for screw terminals is 0.7 N m (6 lb in) (maximum torque is 0.8 N m (7 lb in)).
- Run the supply cables (L1,L2,L3) and supply ground wire through the conduit. Connect the wires to the connector (L1,L2,L3) (2). Recommended torque for screw terminals is 0.7 N m (6 lb in) (maximum torque is 0.8 N m (7 lb in)).
- Insert connector into the drive (2).
- Fasten M4 ring terminals, suitable for the wire size, to the supply ground and motor ground wires. Connect the ground wires to the M4 x 10 taptite screw. Recommended torque is 2 N m (18 lb in) (maximum torque is 3 N m (26 lb in)).
- Run the control cables through the conduit. Connect the control cables to the control connector as required (3). Maximum recommended torque for control terminals is 0.5 N m (4 lb in).
- Replace the control pod cover (4). Recommended torque for the cover screw is 1 N m (9 lb in) (maximum torque is 2 N m (18 lb in)).

