

Right choice for ultimate yield

LSIS strives to maximize customers' profit in gratitude of choosing us for your partner.

Programmable Logic Controller

Temperature Controller

XGT Series

User's Manual

XGF-TC4RT



Safety Instructions

- Read this manual carefully before installing, wiring, operating, servicing or inspecting this equipment.
- Keep this manual within easy reach for quick reference.

LS Industrial Systems

<http://eng.lsis.biz>

Before using the product ...

For your safety and effective operation, please read the safety instructions thoroughly before using the product.

- ▶ Safety Instructions should always be observed in order to prevent accident or risk with the safe and proper use the product.
- ▶ Instructions are divided into “Warning” and “Caution”, and the meaning of the terms is as follows.

 **Warning** This symbol indicates the possibility of serious injury or death if some applicable instruction is violated

 **Caution** This symbol indicates the possibility of severe or slight injury, and property damages if some applicable instruction is violated

Moreover, even classified events under its caution category may develop into serious accidents relying on situations. Therefore we strongly advise users to observe all precautions properly just like warnings.

- ▶ The marks displayed on the product and in the user’s manual have the following meanings.

 Be careful! Danger may be expected.

 Be careful! Electric shock may occur.

- ▶ The user’s manual even after read shall be kept available and accessible to any user of the product.

Safety Instructions for design process

Warning

- ▶ **Please install a protection circuit on the exterior of PLC so that the whole system may operate safely regardless of failures from external power or PLC.** Any abnormal output or operation from PLC may cause serious problems to safety in whole system.
 - Install protection units on the exterior of PLC like an interlock circuit that deals with opposite operations such as emergency stop, protection circuit, and forward/reverse rotation or install an interlock circuit that deals with high/low limit under its position controls.
 - If any system error (watch-dog timer error, module installation error, etc.) is detected during CPU operation in PLC, all output signals are designed to be turned off and stopped for safety. However, there are cases when output signals remain active due to device failures in Relay and TR which can't be detected. Thus, you are recommended to install an addition circuit to monitor the output status for those critical outputs which may cause significant problems.
- ▶ **Never overload more than rated current of output module nor allow to have a short circuit.** Over current for a long period time may cause a fire .
- ▶ **Never let the external power of the output circuit to be on earlier than PLC power,** which may cause accidents from abnormal output operation.
- ▶ **Please install interlock circuits in the sequence program for safe operations in the system when exchange data with PLC or modify operation modes using a computer or other external equipments** Read specific instructions thoroughly when conducting control operations with PLC.

Safety Instructions for design process

Caution

- ▶ **I/O signal or communication line shall be wired at least 100mm away from a high-voltage cable or power line.** Fail to follow this

Safety Instructions on installation process

Caution

- ▶ **Use PLC only in the environment specified in PLC manual or general standard of data sheet.** If not, electric shock, fire, abnormal operation of the product may be caused.
- ▶ **Before install or remove the module, be sure PLC power is off.** If not, electric shock or damage on the product may be caused.
- ▶ **Be sure that every module is securely attached after adding a module or an extension connector.** If the product is installed loosely or incorrectly, abnormal operation, error or dropping may be caused. In addition, contact failures under poor cable installation will be causing malfunctions as well.
- ▶ **Be sure that screws get tighten securely under vibrating environments.** Fail to do so will put the product under direct vibrations which will cause electric shock, fire and abnormal operation.
- ▶ **Do not come in contact with conducting parts in each module,** which may cause electric shock, malfunctions or abnormal operation.

Safety Instructions for wiring process

Warning

- ▶ **Prior to wiring works, make sure that every power is turned off.** If not, electric shock or damage on the product may be caused.
- ▶ **After wiring process is done, make sure that terminal covers are installed properly before its use.** Fail to install the cover may cause electric shocks.

Caution

- ▶ **Check rated voltages and terminal arrangements in each product prior to its wiring process.** Applying incorrect voltages other than rated voltages and misarrangement among terminals may cause fire or malfunctions.
- ▶ **Secure terminal screws tightly applying with specified torque.** If the screws get loose, short circuit, fire or abnormal operation may be caused. Securing screws too tightly will cause damages to the module or malfunctions, short circuit, and dropping.
- ▶ **Be sure to earth to the ground using Class 3 wires for FG terminals which is exclusively used for PLC.** If the terminals not grounded correctly, abnormal operation or electric shock may be caused.
- ▶ **Don't let any foreign materials such as wiring waste inside the module while wiring,** which may cause fire, damage on the product or abnormal operation.
- ▶ **Make sure that pressed terminals get tighten following the specified torque. External connector type shall be pressed or soldered using proper equipments.**

Safety Instructions for test-operation and maintenance

Warning

- ▶ **Don't touch the terminal when powered.** Electric shock or abnormal operation may occur.
- ▶ **Prior to cleaning or tightening the terminal screws, let all the external power off including PLC power.** If not, electric shock or abnormal operation may occur.
- ▶ **Don't let the battery recharged, disassembled, heated, short or soldered.** Heat, explosion or ignition may cause injuries or fire.

Caution

- ▶ **Do not make modifications or disassemble each module.** Fire, electric shock or abnormal operation may occur.
- ▶ **Prior to installing or disassembling the module, let all the external power off including PLC power.** If not, electric shock or abnormal operation may occur.
- ▶ **Keep any wireless equipment such as walkie-talkie or cell phones at least 30cm away from PLC.** If not, abnormal operation may be caused.
- ▶ **When making a modification on programs or using run to modify functions under PLC operations, read and comprehend all contents in the manual fully.** Mismanagement will cause damages to products and accidents.
- ▶ **Avoid any physical impact to the battery and prevent it from dropping as well.** Damages to battery may cause leakage from its fluid. When battery was dropped or exposed under strong impact, never reuse the battery again. Moreover skilled workers are needed when exchanging batteries.

Safety Instructions for waste disposal



Caution

- ▶ **Product or battery waste shall be processed as industrial waste.** The waste may discharge toxic materials or explode itself.

Revision History

Version	Date	Contents	Chapter
V 1.0	'10.9	First edition	-

※ The number of User's manual is indicated right part of the back cover.

© 2009 LS Industrial Systems Co., Ltd All Rights Reserved.

Thank you for purchasing PLC of LS Industrial System Co.,Ltd.

Before use, make sure to carefully read and understand the User's Manual about the functions, performances, installation and programming of the product you purchased in order for correct use and importantly, let the end user and maintenance administrator to be provided with the User's Manual.

The User's Manual describes the product. If necessary, you may refer to the following description and order accordingly. In addition, you may connect our website (<http://eng.lsis.biz/>) and download the information as a PDF file.

Relevant User's Manuals

Title	Description
XG5000 User's Manual (for XGK, XGB)	XG5000 software user manual describing online function such as programming, print, monitoring, debugging by using XGK, XGB CPU
XG5000 User's Manual (for XGI, XGR)	XG5000 software user manual describing online function such as programming, print, monitoring, debugging by using XGI, XGR CPU
XGK/XGB Instructions & Programming User's Manual	User's manual for programming to explain how to use instructions that are used PLC system with XGK, XGB CPU.
XGI/XGR/XEC Instructions & Programming User's Manual	User's manual for programming to explain how to use instructions that are used PLC system with XGI, XGR, XEC CPU.
XGK CPU User's Manual (XGK-CPUA/CPUE/CPUH/CPUS/CPUU)	XGK-CPUA/CPUE/CPUH/CPUS/CPUU user manual describing about XGK CPU module, power module, base, IO module, specification of extension cable and system configuration, EMC standard
XGI CPU User's Manual (XGI-CPUU/CPUH/CPUS)	XGI-CPUU/CPUH/CPUS user manual describing about XGI CPU module, power module, base, IO module, specification of extension cable and system configuration, EMC standard
XGR redundant series User's Manual	XGR- CPUH/F, CPUH/T user manual describing about XGR CPU module, power module, extension drive, base, IO module, specification of extension cable and system configuration, EMC standard

Current XGF-TC4UD manual is written based on the following version.

Related OS version list

Product name	OS version
XGK-CPUH, CPUS, CPUA, CPUE, CPUU	V3.3
XGI-CPUU, CPUH, CPUS	V3.1
XGR-CPUH/F, CPUH/T	V1.6
XG5000(XG-PD)	V3.5

Contents

Chapter 1 Introduction 1-1 ~ 1-2

- 1.1 Features..... 1-1
- 1.2 Terms 1-2

Chapter 2 Specifications 2-1 ~ 2-6

- 2.1 General Specifications 2-1
- 2.2 Performance Specifications 2-2
- 2.3 Names and Functions of Major Components 2-3
- 2.4 Characteristics of Input and Output Conversion..... 2-4
 - 2.4.1 Characteristics of Input Conversion 2-4
 - 2.4.2 Precision by Input Type 2-4
 - 2.4.3 Characteristics of output part conversion 2-5
- 2.5 Main Functions 2-6

Chapter 3 Installation and Wiring 3-1 ~ 3-4

- 3.1 Installation..... 3-1
 - 3.1.1 Conditions for Installation 3-1
 - 3.1.2 Cautions in Handling the Module 3-1
- 3.2 Wiring..... 3-2
 - 3.2.1 Wiring of the Input Part 3-2
 - 3.2.2 Wiring of the Output Part..... 3-4

Chapter 4 Configuration and Functions of Internal Memory (XGK).....4-1 ~ 4-11

- 4.1 U Device Area..... 4-1
 - 4.1.1 U Device Area 4-1
- 4.2 Parameter Setting Area (using PUT/GET command)..... 4-5
 - 4.2.1 Parameter Setting Area 4-5
 - 4.2.2 How to Use PUT/GET Command 4-8

Chapter 5 Configuration and Functions of Internal Memory (XGI/XGR)..... 5-1 ~ 5-15

- 5.1 Global Variables (Data Area) 5-1
 - 5.1.1 Global Variables (Data Area) 5-1
 - 5.1.2 How to Use Global Variables..... 5-3
- 5.2 PUT/GET Function Block Area (Parameter Area) 5-10
 - 5.2.1 PUT/GET Function Block Area (Parameter Area) 5-10
 - 5.2.2 PUT/GET function block..... 5-12
 - 5.2.3 Example of Use of PUT/GET function block 5-14

Chapter 6 Function 6-1 ~ 6-36

- 6.1 Input Parameter 6-1
 - 6.1.1 Type of input 6-1
 - 6.1.2 Input processing 6-4
- 6.2 Control Parameter 6-7
 - 6.2.1 Configuration of the control target..... 6-7
 - 6.2.2 Address the control target 6-9
 - 6.2.3 Control type 6-11

6.2.4 Control processing technique.....	6-15
6.2.5 Auto tuning	6-22
6.3 Output Parameter.....	6-24
6.3.1 Output settings	6-24
6.3.2 Heating output.....	6-25
6.3.3 Cooling output	6-31
6.4 Other Functions	6-35
6.4.1 Alarm function.....	6-35
6.4.2 Output alarm.....	6-36

Chapter 7 Software Package (XG-TCON).....	7-1 ~ 7-37
--	-------------------

7.1 Introduction	7-1
7.1.1 Features of XG-TCON.....	7-1
7.1.2 Functions of XG-TCON.....	7-1
7.1.3 Files Created with XG-TCON.....	7-1
7.2 Main Screen	7-2
7.2.1 Title.....	7-2
7.2.2 Menu	7-3
7.2.3 Tool Bar	7-8
7.2.4 Project Window	7-9
7.2.5 Main Screen	7-10
7.2.6 Command Window.....	7-13
7.2.7 Message Window	7-13
7.2.8 Status Bar.....	7-15
7.3 Screen Components.....	7-16
7.3.1 New Project Dialog.....	7-16
7.3.2 Open Project	7-17
7.3.3 Save As	7-17
7.3.4 Add Module	7-18
7.3.5 Compare Projects.....	7-18
7.3.6 Print Preview Window	7-20
7.3.7 Print Project.....	7-21
7.3.8 Parameter Register Information.....	7-22
7.3.9 Connection Setting.....	7-30
7.3.10 Customize	7-31
7.3.11 Option Dialog.....	7-32
7.3.12 Graph Setting	7-33
7.3.13 Trend Setting.....	7-34
7.3.14 Logging Data Setting.....	7-35
7.3.15 Error Code.....	7-36

Chapter 8 Programming (for XGK).....	8-1 ~ 8-7
---	------------------

8.1 Pre-operation Setting-up Procedure.....	8-1
8.2 Sample Program.....	8-2
8.2.1 Auto Tuning	8-2
8.2.2 Temperature Control Program.....	8-3
8.2.3 Sample Program using PUT/GET Command	8-6

Chapter 9 Programming (for XGI/XGR).....	9-1 ~ 9-9
---	------------------

9.1 Pre-operation Setting-up Procedure.....	9-1
9.2 Sample Program.....	9-2
9.2.1 Auto Tuning	9-2
9.2.2 Temperature Control Program.....	9-3

9.2.3 Sample Program9-7

Chapter 10 Diagnosis 10-1 ~ 10-5

10.1 Error Code10-1
10.2 Diagnosis10-3
 10.2.1 RUN LED is OFF.....10-3
 10.2.2 ALM LED is ON.....10-3
 10.2.3 ERR LED is ON.....10-3
 10.2.4 ERR LED flashes at 1 second intervals.....10-3
 10.2.5 A/D Converted value is not changed.....10-3
 10.2.6 The digital output is not in relation with the analog input value.....10-4
 10.2.7 Out of Control.....10-4
 10.2.8 Checking Temperature Controller Module Status with Software Package.....10-5

Appendix Appendix 1

Chapter 1 Introduction

This User Manual describes the specifications, handling and programming method of the XGF-TC4RT RTD input type Temperature Controller Module (hereinafter, "Temperature controller module") which is used in combination with the CPU modules of XGT PLC series.

The Temperature controller module converts the analog signals (temperature) from the external devices of PLC to i6 bit binary digital signals with signs. The module also provides transistor output for temperature control through PID operation.

1.1 Features

(1) Optimized temperature control function

Temperature control function can be implemented using the built-in input/output function by setting up the PID parameters only.

(2) 3 types of RTD input

PT100, JPT100, PT1000

(3) Isolation between input loops

High reliability signal process can be accomplished without interference between loops.

(4) Transistor outputs

Transistor output available for control output.

(5) Operation parameter setting/monitoring using exclusive software package

Easy to use by using exclusive software package supporting enhanced user interface, which replaced previous method setting operation parameter by instruction. If you use exclusive software package, you can reduce the sequence program. And you can monitor temperature controller module easily by using [Data monitor] and [Trend monitor].

(6) Diverse control type

2 types of control type are supported and each type is as follows.

PID control: general control method using Proportional, Integral, Derivative item.

On/Off control: control method turning on/off MV based on SV

(7) Function detecting disconnection

When using temperature input range, you can detect disconnection of circuit.

(8) Diverse input operation functions

Supports bias, averaging function

(9) Auto-tuning function

Calculation of PID coefficient by auto-tuning is available.

1.2 Terms

1.2.1 PID control (Proportional Integral Derivative Control)

This is one of the feed-back controls keeping output in reference voltage and combination of Proportional control, Proportional-Integral control and Proportional-Derivative control. P control multiplies deviation between reference signal and current signal by P coefficient and makes the control signal. I control executes integral for deviation and adds the result to P control in parallel. D control executes derivative for deviation and adds the results to P control in parallel. It is used to measure reaction of automation system or control reaction. And it is usually used to control temperature, pressure, flow, speed of rotation and can improve the problem of PI or PD control such as transient.

1.2.2 Proportional Control

As one of the control methods, the bigger gap between target value and current value, the bigger manipulated value to return to target value. It is smoother than On/Off control.

1.2.3 On/Off Control

As one of the control methods, it reiterates turning manipulated value on/off and is called Bang Bang control. It has hysteresis characteristic so error within hysteresis range occurs.

1.2.4 Integral Action

Makes the manipulated value proportional to integral value of action signal and called I action. If you use this action, you can eliminate the remaining deviation.

1.2.5 Derivative Action

Makes the manipulated value proportional to derivative value of action signal and called D action. When action signal is getting bigger, it is used to modify action signal properly and make the control stable.

1.2.6 Cascade Control

A series of control steps are connected continuously so one control unit is controlled by other front control unit and controls other back control unit.

1.2.7 Feedback Control

It compares current value with target value and makes the current be target value by using output signal as input signal. Control that removes external disturbance is called constant value control and control whose target value changes rapidly is called variable value control. Both controls make the deviation 0. Process control, automatic control, servo device are classified as Feedback control

1.2.8 XG-TCON

Exclusive software tool to set and monitor input/control/output parameter of temperature controller

Chapter 2 Specifications

2.1 General Specifications

Table 2.1 shows the general specifications of the XGT series.

[Table 2.1] General specifications

No.	Items	Specifications	Related standards			
1	Operating temperature	0 ~ 55 °C				
2	Storage temperature	-25 ~ +70 °C				
3	Operating humidity	5 ~ 95%RH (Non-condensing)				
4	Storage humidity	5 ~ 95%RH (Non-condensing)				
5	Vibration resistance	Occasional vibration			-	IEC61131-2
		Frequency	Acceleration	Amplitude	How many times	
		10 ≤ f < 57Hz	-	0.075mm		
		57 ≤ f ≤ 150Hz	9.8m/s ² (1G)	-	10 times each directions (X, Y and Z)	
		Continuous vibration				
		Frequency	Acceleration	Amplitude		
				10 ≤ f < 57Hz	-	
		57 ≤ f ≤ 150Hz	4.9m/s ² (0.5G)	-		
6	Shock resistance	<ul style="list-style-type: none"> • Peak acceleration: 147 m/s²(15G) • Duration: 11ms • Half-sine, 3 times each direction per each axis 	IEC61131-2			
7	Noise resistance	Square wave impulse noise	±1,500 V		LSIS standard	
		Electrostatic discharge	4kV		IEC61131-2 IEC61000-4-2	
		Radiated electromagnetic field noise	80 ~ 1,000 MHz, 10V/m		IEC61131-2, IEC61000-4-3	
		Fast transient/burst noise	Segment	Power supply module	Digital/analog input/output communication interface	IEC61131-2 IEC61000-4-4
Voltage	2kV		1kV			
8	Environment	Free from corrosive gasses and excessive dust				
9	Altitude	Up to 2,000 ms				
10	Pollution degree	Less than equal to 2				
11	Cooling	Air-cooling				

Note

1) IEC (International Electrotechnical Commission):

An international nongovernmental organization which promotes internationally cooperated standardization in electric/electronic field, publishes international standards and manages applicable estimation system related with.

2) Pollution degree:

An index indicating pollution degree of the operating environment which decides insulation performance of the devices. For instance, Pollution degree 2 indicates the state generally that only non-conductive pollution occurs. However, this state contains temporary conduction due to dew produced.

2.2 Performance Specifications

Table 2.2 shows the performance specifications of the thermo-controller module.

Items		Specifications	
Control loop		4 loop	
RTD type and input range	Pt100	-200 ~ 850 °C	
	JPt100	-200 ~ 600 °C	
	Pt1000	-200 ~ 800 °C	
Precision	Standard precision	±0.2% or less (25 °C, normal temperature)	
	Temperature coefficient	±60ppm/°C (0.006%/°C)	
Resolution		0.1 °C	
Sampling period		400ms/ 4 loop	
Control method		PID CONTROL, ON/OFF CONTROL	
Control parameter	Target value(SV)	Setting within range according to input type (temperature unit setting)	
	Proportional gain	0: ON/OFF CONTROL, REAL	
	Integral time	0: Except integral control, REAL	
	Derivative time	0: Except derivative control, REAL	
Transistor output	Output point	4	
	Rated load voltage	DC 24 V	
	Load voltage range	21.6V~26.4V	
	Max. load current	0.1 A / Output point	
	Max. voltage drop when on	DC 0.3 V or less	
	Leakage current when off	0.1 mA or less	
	Response time	On => Off	1 ms or less
		Off => On	1 ms or less
	Control output cycle	0.5 ~ 100.0 sec (Setting unit: 0.1 sec.)	
Time proportional resolution	Larger one of either 10 ms or 0.05% of the full-scale		
Insulation	Between input channels	Insulation method: transformer, photo-coupler Withstanding voltage: 1500V AC, 50/60Hz 1min, leakage current 10mA or less Insulation resistor: 500V DC, 10 MΩ or above	
	Input terminal – PLC power		
	Output terminal- PLC power		
	Between output channels	Non-insulation	
Access terminal	18 point terminal		
IO occupation point	Fixed: 64 points, movable: 16 points		
Power supply	5 V, DC 24 V		
Current consumed	DC 5 V : 310 mA, DC 24 V : 28 mA		

[Table 2.2] Performance specifications

Note

- 1) When you use the XGR system
- XGR system can be used in an extension base but not in a basic base.

2.3 Names and Functions of Major Components

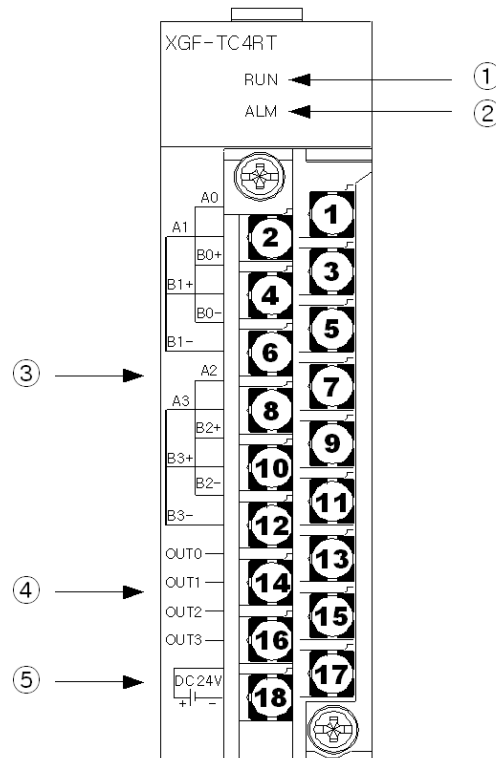

No.	Name	Description
①	RUN LED	<ul style="list-style-type: none"> ▶ Indicates H/W operating status On: normal operation Off: H/W error (request a custom service) Flicker: error have been occurred
②	ALM LED	<ul style="list-style-type: none"> ▶ Alarm status Off: normal input status flicker: alarm have been occurred
③	Terminal block	<ul style="list-style-type: none"> ▶ Input part Connect RTD sensor
④		<ul style="list-style-type: none"> ▶ Output part Terminal block for connecting a external device
⑤		<ul style="list-style-type: none"> ▶ External 24V power supply part Connect a 24V power supply device

2.4 Characteristics of Input and Output Conversion

2.4.1 Characteristics of Input Conversion

RTD input characteristics

It directly connects 3 types of RTD sensors and the input characteristics are as follows.

RTD type	Applying standard	Temperature range		Resistance range
		°C	°F	
Pt100	JIS C1604-1997	-200.0 ~ 850.0	-328.0 ~ 1562.0	18.52 ~ 390.48
JPt100	JIS C1604-1989	-200.0 ~ 600.0	-328.0 ~ 1112.0	17.14 ~ 317.28
Pt1000	DIN 60751	-200.0 ~ 850.0	-328.0 ~ 1562.0	185201 ~ 3904811

2.4.2 Precision by Input Type

The precision by input type is as follows.

RTD type	Display range [°C]	Precision		Resolution
		Room temperature (25°C)	55°C (±100 ppm/°C)	
Pt100	-200 ~ 850	±2.1	±4.0	0.1°C
JPt100	-200 ~ 600	±1.6	±3.6	0.1°C
Pt1000	-200 ~ 850	±2.1	±4.0	0.1°C

Precision in case of 55°C

<How to calculate>

Precision at room temperature + (55°C - 25°C) × 60ppm × whole temperature range

(e.g.) Pt100 type 55°C Precision

$$\pm[2.1 + (55^\circ\text{C} - 25^\circ\text{C}) \times 60\text{ppm} \times 1050] = \pm 3.99^\circ\text{C} = \text{about } \pm 4.0^\circ\text{C}$$

2.4.3 Characteristics of output part conversion

Transistor output characteristics

Transistor output characteristics are as follows.

Item		Specifications		
Transistor output	Output point	4		
	Rated load voltage	DC 24 V		
	Max. load current	0.1 A / output point		
	Max. voltage drop when on	DC 0.3 V or less		
	Leakage current when off	0.1 mA or less		
	Response time	On -> Off	1 ms or less	
		Off -> On	1 ms or less	
	Control output cycle	0.5 ~ 100.0 sec		
Time proportional resolution	Larger one of 10 ms or 0.05% of full-scale			

2.5 Main Functions

Items	Functions	Description	
Functions of input part	Input type	Choose input type	The sensor type can be chosen.
		Handles disconnect	The set input value applies in case of input disconnect.
		Upper limit of effective input	The user defines the effective upper range of the input
		Lower limit of effective input	The user defines the effective lower of the input
	Input processing	Input bias	Bias applies to the input.
		Average type	Select weighted averaging or moving averaging
		Average value	Set averaging value or moving averaging value
Input alarm	Input alarm	The further upper limit, upper limit, lower limit and further lower limit are defined for alarm.	
	Alarm HVS	Set hysteresis for 4 types of input alarm	
Functions of control part	Auto-tuning	Auto-tuning SV	Ordinary SV and Auto-tuning SV are dualized.
		Auto-tuning Hysteresis	Auto-tuning considering the sensor vibration.
	Target setting	SV upper/lower limit	Caps the SV upper and lower limits.
		PV tracking	Set to go along PV to prevent sudden change of SV
	Control setting	Control type	Select one from PID or ON/OFF control
		ON/OFF control HYS	Set hysteresis used for ON/OFF control
		Forward/reverse action	Forward/reverse action can be converted
		Dead band	Set SV upper/lower dead band area
		Anti-windup	Removes overshoot by preventing over-integration occurring from start, disturbance and rapid change in SV
		No impulse manual escape	When manual operation converts auto operation, it relieve the impulse and protect the driver
		Choose proportional source	Choose the source to perform the proportional operation between PV/EV.
	Control factor	Choose differential source	Choose the source to perform differential operation between PV/EV.
		Set control factor	Control factors can be changed as a whole set.
Control BIAS		Bias to MV after control	
Functions of output part	Basic setting	Heating/cooling	Heating/cooling/heating and cooling can be set.
	Output setting Heating/Cooling Setting	PWM output	PWM output is supported and the cycle can be set.
		Output upper/lower limit	The output value can be capped as the upper and lower limit.
		Output change limit	Limited when the output gets out of a certain range.
		Output reference	Bias after setting the reference value to the output.
	Output alarm	Failure output	Output can be set in case of failure.
		Output alarm	When output reaches the designated upper/lower limit, it creates alarm
Alarm HYS		Sets hysteresis for output alarm	

Chapter 3 Installation and Wiring

3.1 Installation

3.1.1 Conditions for Installation

Although this module has high reliability regardless of the surrounding conditions, pay attention to the following conditions to secure the reliability and stability of the system.

(1) Environment

- Install on a water-proof and vibration-proof control panel.
- Where there is no persistent shock or vibration
- Where there is no direct sun
- Where there is no condensation due to sudden change in the temperature
- Where the temperature is kept at 0-55 °C

(2) Installation work

- Be careful so that foreign substances do not enter the PLC when you drill screw holes or do the wiring work.
- Put the module where you can easily manipulate.
- Do not install the module in the same panel as a high voltage device.
- Place the module at least 50mm away from a duct and other nearby modules.
- Connect the module to earth where there is not much noise.

3.1.2 Cautions in Handling the Module

The following is what you need to pay attention to from when you open the module to when you install it.

- (1) Do not drop it or give a strong shock.
- (2) Do not detach the PCB from the case, which might cause a failure.
- (3) Be careful so that foreign substances do not enter the PLC when you drill screw holes or do the wiring work. If there is any inside, remove them.
- (4) Do not mount or dismount the module while the power is on.
- (5) Install the module more than 100mm away when you place the module in front of the PLC to avoid the radiating noise or heat (inside the door). Any device should be placed more than 50mm away from either side of the base.

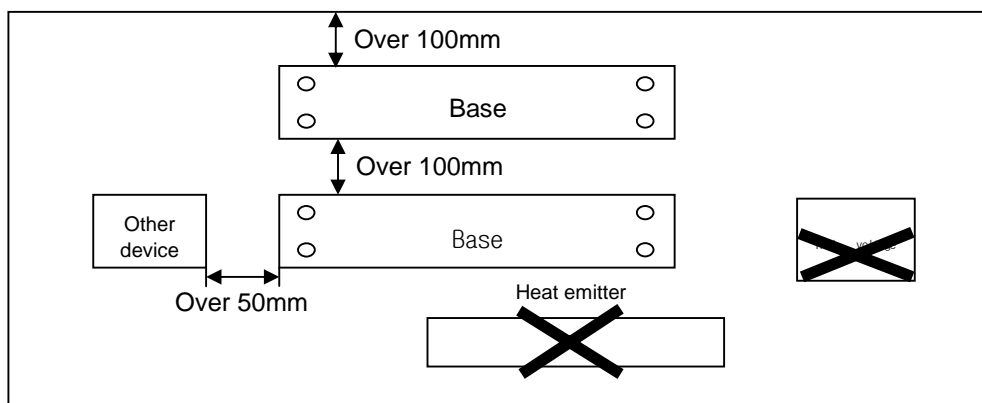

3.2 Wiring

3.2.1 Wiring of the Input Part

(1) Input part 2-wire type wiring

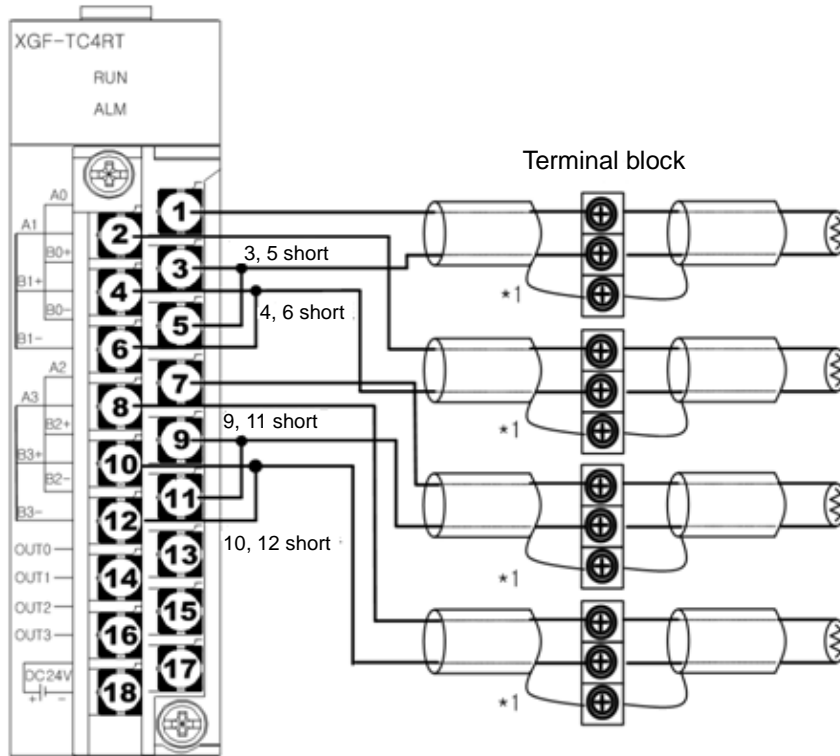

*1 In case sensor and compensating wire is shielded, shield connection to PLC FG is available.

(2) Input part 3-wire type wiring

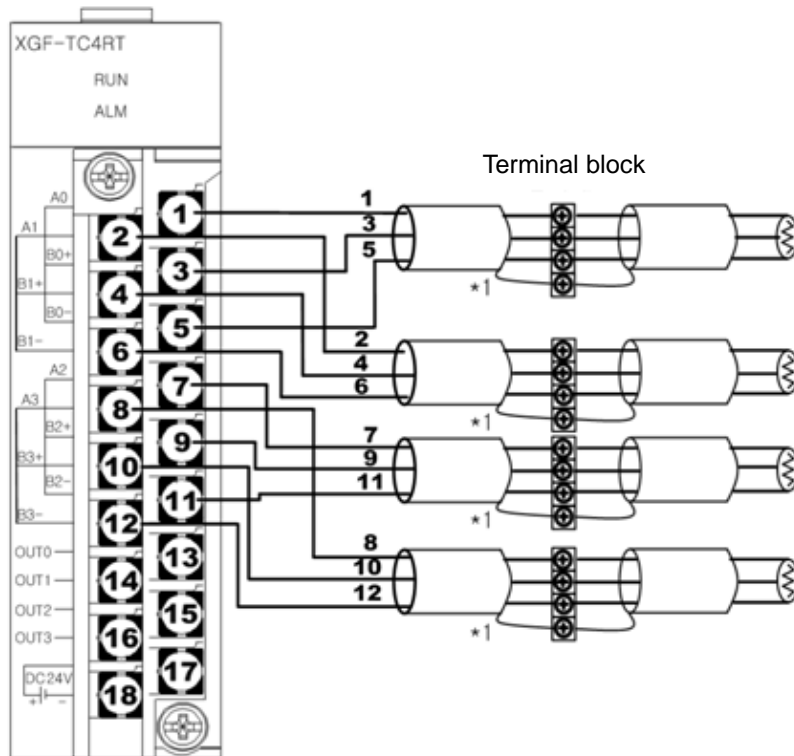

*1 In case sensor and compensating wire is shielded, shield connection to PLC FG is available.

(2) Input part 4-wire type wiring

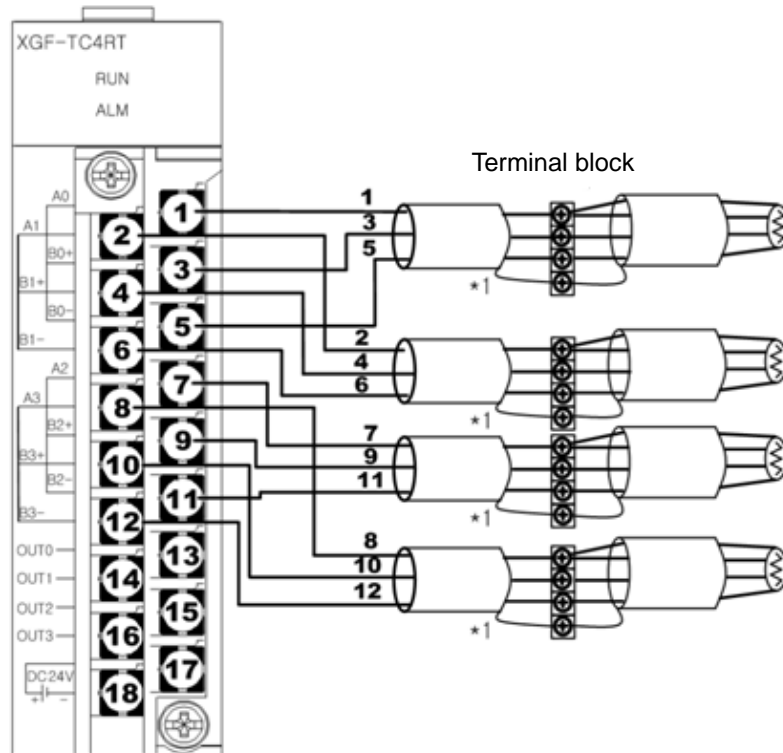

*1 In case sensor and compensating wire is shielded, shield connection to PLC FG is available.

3.2.2 Wiring of the Output Part

(1) Output part wiring

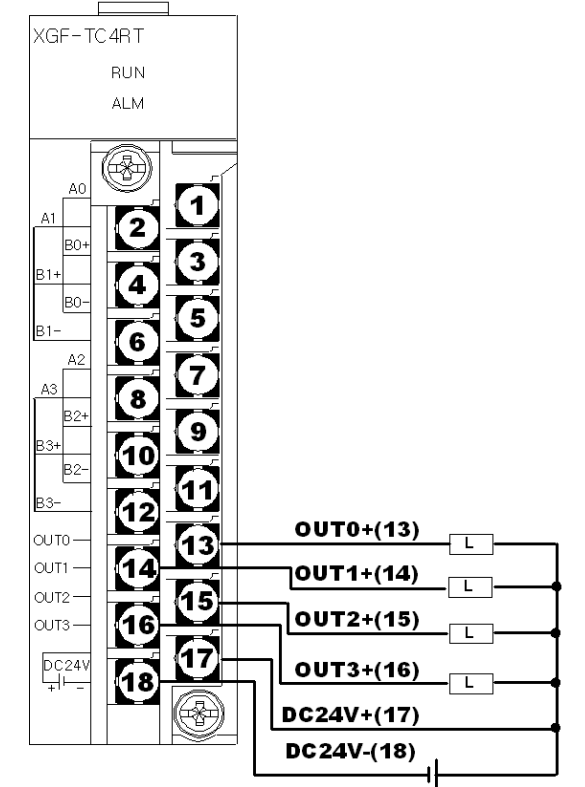

– It is recommended you use the noise filter for the module when you use an external power supply.

Chapter 4 Configuration and Functions of Internal Memory (XGK)

4.1 U Device Area

4.1.1 U Device Area

Table 4.1 shows the U device area of the temperature-controller.

Device		Symbol	Description
Word	Bit		
U00.00	U00.00.0	_00_CH0_ACT	channel0 operating
	U00.00.1	_00_CH1_ACT	channel1 operating
	U00.00.2	_00_CH2_ACT	channel2 operating
	U00.00.3	_00_CH3_ACT	channel3 operating
	These are read-only areas and display the operating information of each channel. When the corresponding bit is On, it means the corresponding channel is operating.		
	U00.00.4	_00_CH0_BOUT	channel0 disconnect
	U00.00.5	_00_CH1_BOUT	channel1 disconnect
	U00.00.6	_00_CH2_BOUT	channel2 disconnect
	U00.00.7	_00_CH3_BOUT	channel3 disconnect
	These are read-only areas and display the disconnection of each channel. When the corresponding bit is On, it means the sensor of the corresponding channel is disconnected.		
	U00.00.8	_00_CH0_ADCERR	channel0 A/D CONVERSION error
	U00.00.9	_00_CH1_ADCERR	channel1 A/D CONVERSION error
	U00.00.A	_00_CH2_ADCERR	channel2 A/D CONVERSION error
	U00.00.B	_00_CH3_ADCERR	channel3 A/D CONVERSION error
	These are read-only areas and display the input part error of each channel. When the corresponding bit is On, it means there is an error at the input part of the channel.		
	U00.00.D	_00_CHECKSUMERR	module backup memory error
These are read-only areas and display the backup memory error of the module. When the corresponding bit is On, it means there is an error during the backup of the module.			
U00.00.E	_00_ERR	module error	
These are read-only areas and display the action error of the module. When the corresponding bit is On, it means there is an error about the action of the module.			
U00.00.F	_00_RDY	module Ready	
These are read-only areas and display the action error of the module. When the corresponding bit is On, the module is on normal standby.			
U00.01	U00.01.0	_00_WR_ING	saving parameter (writing)
	These are read-only areas and display the backup action of the module. When the corresponding bit is On, the module data is being saved		
	U00.01.8	_00_RD_ING	Restoring parameter (reading)
These are read-only areas and display the backup action of the module. When the corresponding bit is On, the module data is being restored.			

[Table 4 .1] U device area

Device		Device	Description
Word	Word		
U00.02	U00.02.0	_00_CH0_ALINHH	channel0 input alarm further upper limit
	U00.02.1	_00_CH0_ALINH	channel0 input alarm upper limit
	U00.02.2	_00_CH0_ALINL	channel0 input alarm lower limit
	U00.02.3	_00_CH0_ALINLL	channel0 input alarm further lower limit
	U00.02.4	_00_CH0_ALHOH	channel0 heating output alarm upper limit
	U00.02.5	_00_CH0_ALHOL	channel0 heating output alarm lower limit
	U00.02.6	_00_CH0_ALCOH	channel0 cooling output alarm upper limit
	U00.02.7	_00_CH0_ALCOL	channel0 cooling output alarm lower limit
U00.03	U00.03.0	_00_CH1_ALINHH	channel1 input alarm further upper limit
	U00.03.1	_00_CH1_ALINH	channel1 input alarm upper limit
	U00.03.2	_00_CH1_ALINL	channel1 input alarm lower limit
	U00.03.3	_00_CH1_ALINLL	channel1 input alarm further lower limit
	U00.03.4	_00_CH1_ALHOH	channel1 heating output alarm upper limit
	U00.03.5	_00_CH1_ALHOL	channel1 heating output alarm lower limit
	U00.03.6	_00_CH1_ALCOH	channel1 cooling output alarm upper limit
	U00.03.7	_00_CH1_ALCOL	channel1 cooling output alarm lower limit
U00.04	U00.04.0	_00_CH2_ALINHH	channel2 input alarm further upper limit
	U00.04.1	_00_CH2_ALINH	channel2 input alarm upper limit
	U00.04.2	_00_CH2_ALINL	channel2 input alarm lower limit
	U00.04.3	_00_CH2_ALINLL	channel2 input alarm further lower limit
	U00.04.4	_00_CH2_ALHOH	channel2 heating output alarm upper limit
	U00.04.5	_00_CH2_ALHOL	channel2 heating output alarm lower limit
	U00.04.6	_00_CH2_ALCOH	channel2 cooling output alarm upper limit
	U00.04.7	_00_CH2_ALCOL	channel2 cooling output alarm lower limit
U00.05	U00.05.0	_00_CH3_ALINHH	channel3 input alarm further upper limit
	U00.05.1	_00_CH3_ALINH	channel3 input alarm upper limit
	U00.05.2	_00_CH3_ALINL	channel3 input alarm lower limit
	U00.05.3	_00_CH3_ALINLL	channel3 input alarm further lower limit
	U00.05.4	_00_CH3_ALHOH	channel3 heating output alarm upper limit
	U00.05.5	_00_CH3_ALHOL	channel3 heating output alarm lower limit
	U00.05.6	_00_CH3_ALCOH	channel3 cooling output alarm upper limit
	U00.05.7	_00_CH3_ALCOL	channel3 cooling output alarm lower limit
U00.06	-	_00_CH0_PV	channel0 input value
U00.07	-	_00_CH1_PV	channel1 input value
U00.08	-	_00_CH2_PV	channel2 input value
U00.09	-	_00_CH3_PV	channel3 input value
U00.10	-	_00_CH0_HOUT	channel0 heating output value
U00.11	-	_00_CH1_HOUT	channel1 heating output value
U00.12	-	_00_CH2_HOUT	channel2 heating output value
U00.13	-	_00_CH3_HOUT	channel3 heating output value
U00.14	-	_00_CH0_COUT	channel0 cooling output value
U00.15	-	_00_CH1_COUT	channel1 cooling output value
U00.16	-	_00_CH2_COUT	channel2 cooling output value
U00.17	-	_00_CH3_COUT	channel3 cooling output value

Device		Device	Description
Word	Word		
U00.18	U00.18.0	_00_CH0_RUN	channel0 operating command
	U00.18.1	_00_CH0_MAN	channel0 manual mode command
	U00.18.2	_00_CH0_ATEN	channel0 auto-tuning command
	U00.18.3	_00_CH0_EXIN	channel0 external input allowing command
U00.19	U00.19.0	_00_CH1_RUN	channel1 operating command
	U00.19.1	_00_CH1_MAN	channel1 manual mode command
	U00.19.2	_00_CH1_ATEN	channel1 auto-tuning command
	U00.19.3	_00_CH1_EXIN	channel1 external input allowing command
U00.20	U00.20.0	_00_CH2_RUN	channel2 operating command
	U00.20.1	_00_CH2_MAN	channel2 manual mode command
	U00.20.2	_00_CH2_ATEN	channel2 auto-tuning command
	U00.20.3	_00_CH2_EXIN	channel2 external input allowing command
U00.21	U00.21.0	_00_CH3_RUN	channel3 operating command
	U00.21.1	_00_CH3_MAN	channel3 manual mode command
	U00.21.2	_00_CH3_ATEN	channel3 auto-tuning command
	U00.21.3	_00_CH3_EXIN	channel3 external input allowing command
U00.22	-	_00_CH0_EXINV	channel0 external input data
U00.23	-	_00_CH1_EXINV	channel1 external input data
U00.24	-	_00_CH2_EXINV	channel2 external input data
U00.25	-	_00_CH3_EXINV	channel3 external input data
U00.26	-	_00_CH0_CSET	channel0 control set selection
U00.27	-	_00_CH1_CSET	channel1 control set selection
U00.28	-	_00_CH2_CSET	channel2 control set selection
U00.29	-	_00_CH3_CSET	channel3 control set selection
U00.30	U00.30.0	_00_WRITE	parameter backup command (write)
	U00.30.8	_00_READ	parameter restoring command (read)

- (1) In device allocation, x and y respectively refer to the base number and the slot number with a module.
- (2) The channel 0 conversion value of the thermo-controller mounted on base No. 0, slot No. 4 is expressed as U04.06.

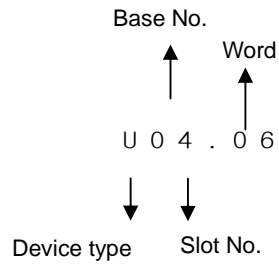

- (3) The channel0 operating command of a thermo-controller mounted on base No. 0 and slot No. 5 is expressed as U05.18.0. (when mounted on slot No. 10, it is U0A.18.0)

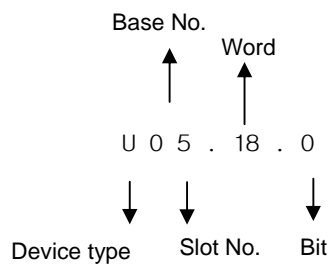

Note

U device: The memory of PLC CPU that you use to read or write a certain area (defined in the data and module that should be periodically read) of a special/ communication module in XGK PLC per each scan. The data you always read and write is allotted in this area like the conversion data of the special module. Like other devices, it can be directly used for ordinary commands such as MOV, CMP, and ADD (PUT/GET command should be used for the parameter area of the module).

4.2 Parameter Setting Area (using PUT/GET command)

- To set the parameter, we recommend you use the software package (XG-TCON) exclusively for the temperature-controller.
- Below is how to change the parameter by using the PUT/GET command in XG5000 program.

4.2.1 Parameter Setting Area

Channel				Read/Write	Type	Description
channel0	channel1	channel2	channel3			
0	128	256	384	Read	BIT	channel status
1	129	257	385	Read	INT	sensor input value
2	130	258	386	Read	INT	Current control target
3	131	259	387	Read	INT	control output value
4	132	260	388	Read	REAL	control error
6	134	262	390	Read	WORD	auto-tuning step
9	137	265	393	Read	WORD	channel error
10	138	266	394	Read/Write	BIT	channel command
11	139	267	395	Read/Write	WORD	scale decimal point set value
12	140	268	396	Read/Write	WORD	dead zone(blind sector) set value
13	141	269	397	Read/Write	BIT	input setting
14	142	270	398	Read/Write	WORD	sensor code
15	143	271	399	Read/Write	INT	scale upper limit set value
16	144	272	400	Read/Write	INT	scale lower limit set value
18	146	274	402	Read/Write	INT	effective input upper limit set value
19	147	275	403	Read/Write	INT	effective input lower limit set value
20	148	276	404	Read/Write	INT	input alarm further upper limit set value
21	149	277	405	Read/Write	INT	input alarm upper limit set value
22	150	278	406	Read/Write	INT	input alarm lower limit set value
23	151	279	407	Read/Write	INT	input alarm further lower limit set value
24	152	280	408	Read/Write	WORD	LOWCUT set value
25	153	281	409	Read/Write	INT	input BIAS set value
26	154	282	410	Read/Write	WORD	filter factor/average frequency set value
27	155	283	411	Read/Write	WORD	filter factor/average frequency set value
28	156	284	412	Read/Write	BIT	control setting
29	157	285	413	Read/Write	INT	auto-tuning target
30	158	286	414	Read/Write	WORD	auto-tuning hysteresis set value
31	159	287	415	Read/Write	INT	control target upper limit set value
32	160	288	416	Read/Write	INT	control target lower limit set value
33	161	289	417	Read/Write	WORD	rising PV tracking set value
34	162	290	418	Read/Write	WORD	falling PV tracking set value
35	163	291	419	Read/Write	WORD	ONOFF control hysteresis set value
36	164	292	420	Read/Write	INT	heating cooling proportional value

Channel				Read/ Write	Type	Description
channel0	channel1	channel2	channel3			
37	165	293	421	Read/Write	WORD	heating PWM cycle setting
38	166	294	422	Read/Write	INT	heating output upper limit
39	167	295	423	Read/Write	INT	heating output lower limit
40	168	296	424	Read/Write	WORD	heating output change upper limit
41	169	297	425	Read/Write	INT	heating output reference value
42	170	298	426	Read/Write	INT	failure heating output setting
43	171	299	427	Read/Write	INT	heating manual output value
44	172	300	428	Read/Write	INT	heating output upper limit alarm value
45	173	301	429	Read/Write	INT	heating output lower limit alarm value
48	176	304	432	Read/Write	WORD	cooling PWM cycle setting
49	177	305	433	Read/Write	INT	cooling output upper limit
50	178	306	434	Read/Write	INT	cooling output lower limit
51	179	307	435	Read/Write	WORD	cooling output change upper limit
52	180	308	436	Read/Write	INT	cooling output reference value
53	181	309	437	Read/Write	INT	failure cooling output setting
54	182	310	438	Read/Write	INT	cooling manual output value
55	183	311	439	Read/Write	INT	cooling output upper limit alarm value
56	184	312	440	Read/Write	INT	cooling output lower limit alarm value
57	185	313	441	Read/Write	WORD	output alarm common hysteresis value
59	187	315	443	Read/Write	WORD	cool access point compensation method
60	188	316	444	Read/Write	INT	External RJC
61	189	317	445	Read	INT	cool access point compensation temperature monitoring
64	192	320	448	Read/Write	INT	target set value 0
65	193	321	449	Read/Write	INT	cycle setting 0
66	194	322	450	Read/Write	REAL	proportional factor set value 0
68	196	324	452	Read/Write	REAL	integral factor set value 0
70	198	326	454	Read/Write	REAL	differential factor set value 0
72	200	328	456	Read/Write	INT	control BIAS set value 0
73	201	329	457	Read/Write	INT	target set value 1
74	202	330	458	Read/Write	INT	cycle setting 1
75	203	331	459	Read/Write	REAL	proportional factor set value 1
77	205	333	461	Read/Write	REAL	integral factor set value 1
79	207	335	463	Read/Write	REAL	differential factor set value 1
81	209	337	465	Read/Write	INT	control BIAS set value 1
82	210	338	466	Read/Write	INT	target set value 2
83	211	339	467	Read/Write	INT	cycle setting 2
84	212	340	468	Read/Write	REAL	proportional factor set value 2
86	214	342	470	Read/Write	REAL	integral factor set value 2
88	216	344	472	Read/Write	REAL	differential factor set value 2
90	218	346	474	Read/Write	INT	control BIAS set value 2
91	219	347	475	Read/Write	INT	target set value 3

Channel				Read/ Write	Type	Description
channel0	channel1	channel2	channel3			
92	220	348	476	Read/Write	INT	cycle setting 3
93	221	349	477	Read/Write	REAL	proportional factor set value 3
95	223	351	479	Read/Write	REAL	integral factor set value 3
97	225	353	481	Read/Write	REAL	differential factor set value 3
99	227	355	483	Read/Write	INT	control BIAS set value 3
100	228	356	484	Read/Write	INT	target set value 4
101	229	357	485	Read/Write	INT	cycle setting 4
102	230	358	486	Read/Write	REAL	proportional factor set value 4
104	232	360	488	Read/Write	REAL	integral factor set value 4
106	234	362	490	Read/Write	REAL	differential factor set value 4
108	236	364	492	Read/Write	INT	control BIAS set value 4
109	237	365	493	Read/Write	INT	target set value 5
110	238	366	494	Read/Write	INT	cycle setting 5
111	239	367	495	Read/Write	REAL	proportional factor set value 5
113	241	369	497	Read/Write	REAL	integral factor set value 5
115	243	371	499	Read/Write	REAL	differential factor set value 5
117	245	373	501	Read/Write	INT	control BIAS set value 5

Note) Read/Write is written based on the PLC. In case of Read, PLC reads the data from the module and in case of Write, PLC writes the data to the module

4.2.2 How to Use PUT/GET Command

(1) PUT command

Command	Areas available														step	Flag			
	PMK	F	L	T	C	S	Z	D.x	R.x	constant	U	N	D	R		error (F110)	Zero (F111)	carry (F112)	
PUT(P)	sl	-	-	-	-	-	-	-	-	-	O	-	-	-	-	4~7	-	-	-
	S1	-	-	-	-	-	-	-	-	-	O	-	-	-	-				
	S2	O	-	O	-	-	-	-	-	-	O	O	O	O					
	N	O	-	O	-	-	-	-	-	-	O	-	-	-					

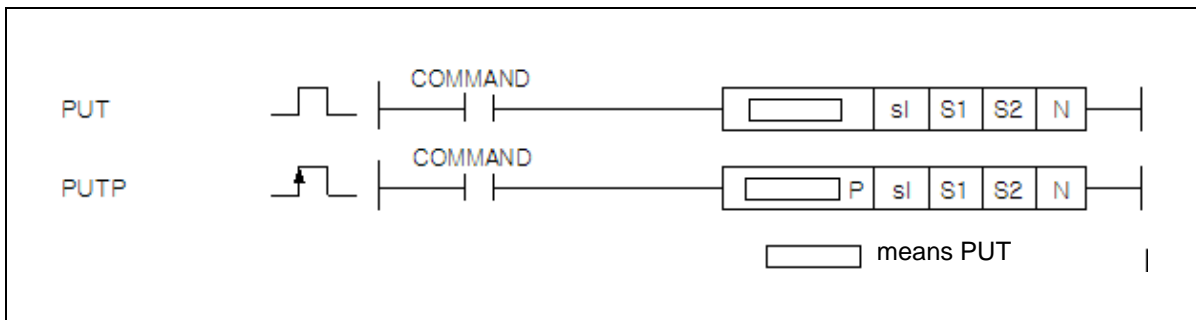

[Area setting]

Operand	Description	Data size
sl	The number of the slot with a special module (set as a hexadecimal number)	WORD
S1	The channel of the internal memory of a special module	WORD
S2	The first number of constant of the device where the data is stored which you want to save in the special module	WORD
N	The number of the data to be stored	WORD

[Flag set]

Flag	Description	Device No.
PUT/GET error	- when the special module is not in the designated slot - when the PUT/GET command has not been properly carried out	F0015 ~ F0022

- This command is used when you want to use data for the special module with a memory.
- It uses N word data from the device designated as S2 for the memory (designated as S2) of the special module designated as sl (the slot number of the special module).
- When the special module is not in the place designated as sl (the slot number of the special module) of the PUT command has not been properly carried out, the bit of the corresponding place of F0015~F0022(WORD), which is PUT/GET error Flag, is set.
- sl (the slot number of the special module) shall be set in two places as a hexadecimal number. As shown below, for instance, in the case of h14, the number 1 refers to the number of the base and 4 the slot number.

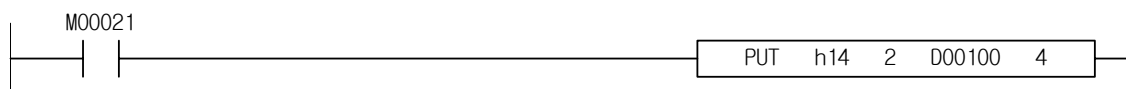

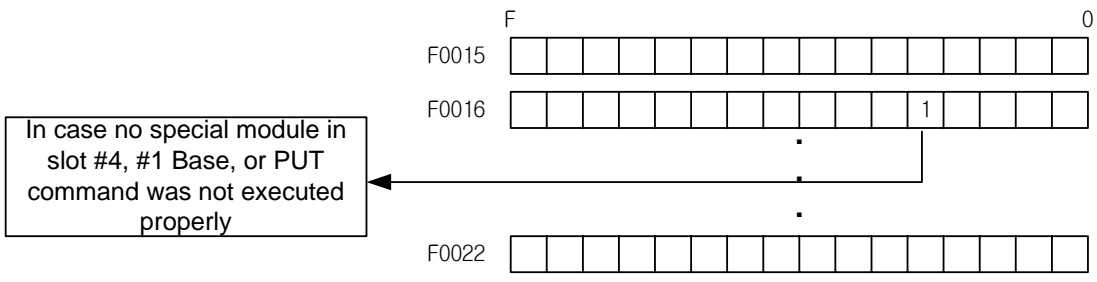

(2) Example of usage of PUT command

(a) The program that uses 40 words of D1000 ~D1039 from 10Channel to 40 channel of the special module mounted on slot number 7 of base 0 when the M00000 of the input signal is On.

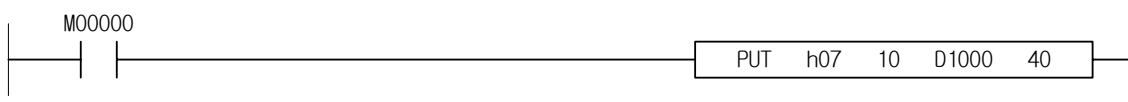

(b) The program that uses the data of 3 words between 5Channel and 7Channel of the internal memory of A/D module mounted in slot 3 of base 0 for the contents of words M00010~M00012

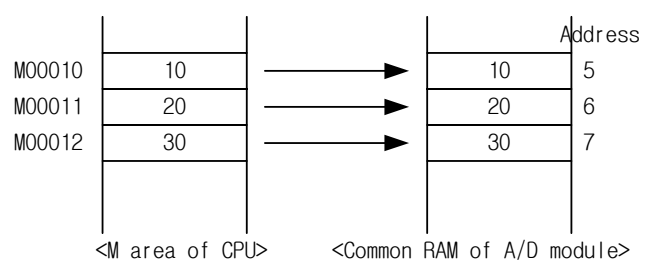
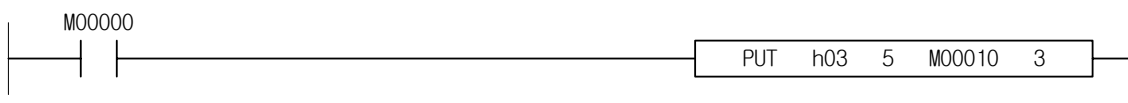

(3) GET command

Command	Available area														step	Flag			
	PMK	F	L	T	C	S	Z	D.x	R.x	con stan t	U	N	D	R		error (F110)	zero (F111)	carry (F112)	
GET(P)	sl	-	-	-	-	-	-	-	-	-	O	-	-	-	-	4~7	-	-	-
	S	-	-	-	-	-	-	-	-	-	O	-	-	-	-				
	D	O	-	O	-	-	-	-	-	-	-	O	O	O	O				
	N	O	-	O	-	-	-	-	-	-	O	O	O	O	O				

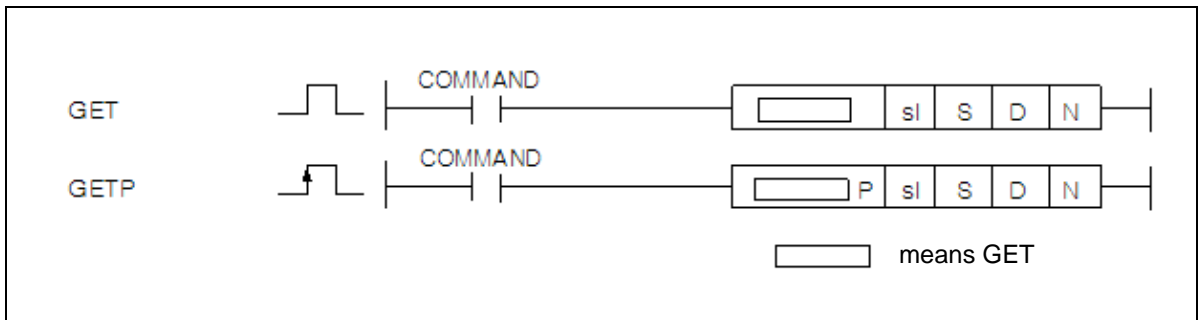

[Area setting]

Operand	Description	Data size
sl	The number of the slot with a special module (set as a hexadecimal number)	WORD
S	The starting channel of the internal memory of a special module	WORD
D	The first number of the device in the CPU where the data to read will be stored	WORD
N	The number of data to read	WORD

[Flag set]

Flag	Description	Device No.
PUT/GET error	- when the special module is not in the designated slot - when the PUT/GET command has not been properly carried out	F0015 ~ F0022

- This command is used when you want to read data for the special module with a memory
- It saves the N word data in the internal device area designated as D from the memory (designated as S: address) of the memory of the special module designated as sl (the slot number of the special module).
- When the special module is not in the place designated as sl (the slot number of the special module) or the GET command has not been properly carried out, the bit of the corresponding place of F0015~F0022(WORD), which is the PUT/GET error Flag, is set.
- sl (the slot number of the special module) shall be set in two places as a hexadecimal number. As shown below, for instance, in the case of h10, the number 1 refers to the number of the base and 0 the slot number.

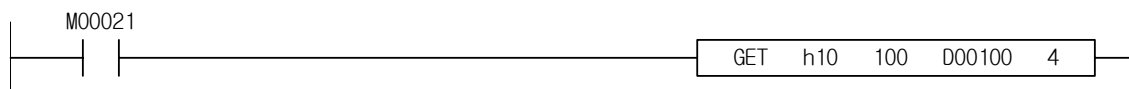

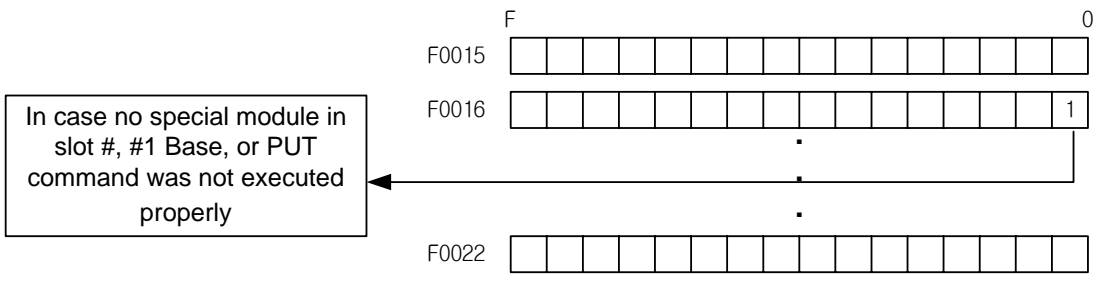

(4) Example of usage of GET command

(a) It stores 4 word data between D00010 and D00013 from the internal memory 0 channel of the special module mounted in the third slot of base 0 when P0001 is on.

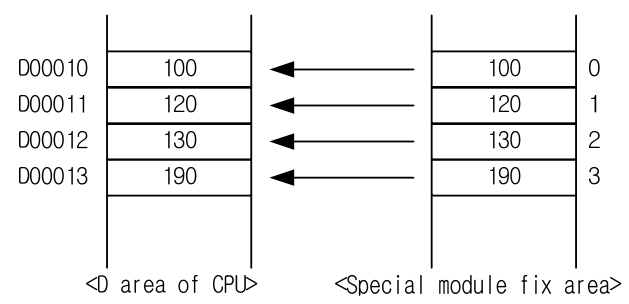
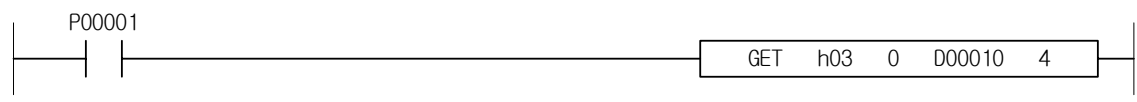

Chapter 5 Configuration and Functions of Internal Memory (XGI/XGR)

5.1 Global Variables (Data Area)

5.1.1 Global Variables (Data Area)

Table 5.1 shows the U device area of the thermo-controller.

Global variables	Data type	Description
_xxyy_CH0_ACT	BOOL	channel0 operating
_xxyy_CH1_ACT	BOOL	channel1 operating
_xxyy_CH2_ACT	BOOL	channel2 operating
_xxyy_CH3_ACT	BOOL	channel3 operating
_xxyy_CH0_BOUT	BOOL	channel0 disconnect
_xxyy_CH1_BOUT	BOOL	channel1 disconnect
_xxyy_CH2_BOUT	BOOL	channel2 disconnect
_xxyy_CH3_BOUT	BOOL	channel3 disconnect
_xxyy_CH0_ADCERR	BOOL	channel0 A/D conversion error
_xxyy_CH1_ADCERR	BOOL	channel1 A/D conversion error
_xxyy_CH2_ADCERR	BOOL	channel2 A/D conversion error
_xxyy_CH3_ADCERR	BOOL	channel3 A/D conversion error
_xxyy_CHECKSUMERR	BOOL	module backup memory error
_xxyy_ERR	BOOL	module error
_xxyy_RDY	BOOL	module Ready
_xxyy_WR_ING	BOOL	parameter backup (writing)
_xxyy_RD_ING	BOOL	parameter restoring (reading)
_xxyy_CH0_ALINHH	BOOL	channel0 input alarm further upper limit
_xxyy_CH0_ALINH	BOOL	channel0 input alarm upper limit
_xxyy_CH0_ALINL	BOOL	channel0 input alarm lower limit
_xxyy_CH0_ALINLL	BOOL	channel0 input alarm further lower limit
_xxyy_CH0_ALHOH	BOOL	channel0 heating output alarm upper limit
_xxyy_CH0_ALHOL	BOOL	channel0 heating output alarm lower limit
_xxyy_CH0_ALCOH	BOOL	channel0 cooling output alarm upper limit
_xxyy_CH0_ALCOL	BOOL	channel0 cooling output alarm lower limit
_xxyy_CH1_ALINHH	BOOL	channel1 input alarm further upper limit
_xxyy_CH1_ALINH	BOOL	channel1 input alarm upper limit
_xxyy_CH1_ALINL	BOOL	channel1 input alarm lower limit
_xxyy_CH1_ALINLL	BOOL	channel1 input alarm further lower limit
_xxyy_CH1_ALHOH	BOOL	channel1 heating output alarm upper limit
_xxyy_CH1_ALHOL	BOOL	channel1 heating output alarm lower limit
_xxyy_CH1_ALCOH	BOOL	channel1 cooling output alarm upper limit
_xxyy_CH1_ALCOL	BOOL	channel1 cooling output alarm lower limit

[Table 5. 1] U device area

- In device assignment, xx represents the number of the base with a module and yy the number of the slot with a module.

Chapter 5 Configuration and Functions of Internal Memory (XGI/XGR)

Global variables	Data type	Description
_xxyy_CH2_ALINHH	BOOL	channel2 input alarm further upper limit
_xxyy_CH2_ALINH	BOOL	channel2 input alarm upper limit
_xxyy_CH2_ALINL	BOOL	channel2 input alarm lower limit
_xxyy_CH2_ALINLL	BOOL	channel2 input alarm further lower limit
_xxyy_CH2_ALHOH	BOOL	channel2 heating output alarm upper limit
_xxyy_CH2_ALHOL	BOOL	channel2 heating output alarm lower limit
_xxyy_CH2_ALCOH	BOOL	channel2 cooling output alarm upper limit
_xxyy_CH2_ALCOL	BOOL	channel2 cooling output alarm lower limit
_xxyy_CH3_ALINHH	BOOL	channel3 input alarm further upper limit
_xxyy_CH3_ALINH	BOOL	channel3 input alarm upper limit
_xxyy_CH3_ALINL	BOOL	channel3 input alarm lower limit
_xxyy_CH3_ALINLL	BOOL	channel3 input alarm further lower limit
_xxyy_CH3_ALHOH	BOOL	channel3 heating output alarm upper limit
_xxyy_CH3_ALHOL	BOOL	channel3 heating output alarm lower limit
_xxyy_CH3_ALCOH	BOOL	channel3 cooling output alarm upper limit
_xxyy_CH3_ALCOL	BOOL	channel3 cooling output alarm lower limit
_xxyy_CH0_PV	WORD	channel0 input value
_xxyy_CH1_PV	WORD	channel1 input value
_xxyy_CH2_PV	WORD	channel2 input value
_xxyy_CH3_PV	WORD	channel3 input value
_xxyy_CH0_HOUT	WORD	channel0 heating output value
_xxyy_CH1_HOUT	WORD	channel1 heating output value
_xxyy_CH2_HOUT	WORD	channel2 heating output value
_xxyy_CH3_HOUT	WORD	channel3 heating output value
_xxyy_CH0_COUT	WORD	channel0 cooling output value
_xxyy_CH1_COUT	WORD	channel1 cooling output value
_xxyy_CH2_COUT	WORD	channel2 cooling output value
_xxyy_CH3_COUT	WORD	channel3 cooling output value
_xxyy_CH0_RUN	BOOL	channel0 operating command
_xxyy_CH0_MAN	BOOL	channel0 manual mode command
_xxyy_CH0_ATEN	BOOL	channel0 auto-tuning command
_xxyy_CH0_EXIN	BOOL	channel0 external input allowing command
_xxyy_CH1_RUN	BOOL	channel1 operating command
_xxyy_CH1_MAN	BOOL	channel1 manual mode command
_xxyy_CH1_ATEN	BOOL	channel1 auto-tuning command
_xxyy_CH1_EXIN	BOOL	channel1 external input allowing command
_xxyy_CH2_RUN	BOOL	channel2 operating command
_xxyy_CH2_MAN	BOOL	channel2 manual mode command
_xxyy_CH2_ATEN	BOOL	channel2 auto-tuning command
_xxyy_CH2_EXIN	BOOL	channel2 external input allowing command
_xxyy_CH3_RUN	BOOL	channel3 operating command
_xxyy_CH3_MAN	BOOL	channel3 manual mode command
_xxyy_CH3_ATEN	BOOL	channel3 auto-tuning command
_xxyy_CH3_EXIN	BOOL	channel3 external input allowing command
_xxyy_CH0_EXINV	BOOL	channel0 external input data
_xxyy_CH1_EXINV	BOOL	channel1 external input data
_xxyy_CH2_EXINV	BOOL	channel2 external input data
_xxyy_CH3_EXINV	BOOL	channel3 external input data
_xxyy_CH0_CSET	WORD	channel0 control set selection
_xxyy_CH1_CSET	WORD	channel1 control set selection
_xxyy_CH2_CSET	WORD	channel2 control set selection
_xxyy_CH3_CSET	WORD	channel3 control set selection
_xxyy_WRITE	BOOL	parameter backup command (writing)
_xxyy_READ	BOOL	parameter restoring command (reading)

5.1.2 How to Use Global Variables

(1) Registration of the I/O Parameter

- Register the module you want to use with I/O parameter.

(a) Double click on I/O parameter in the project window.

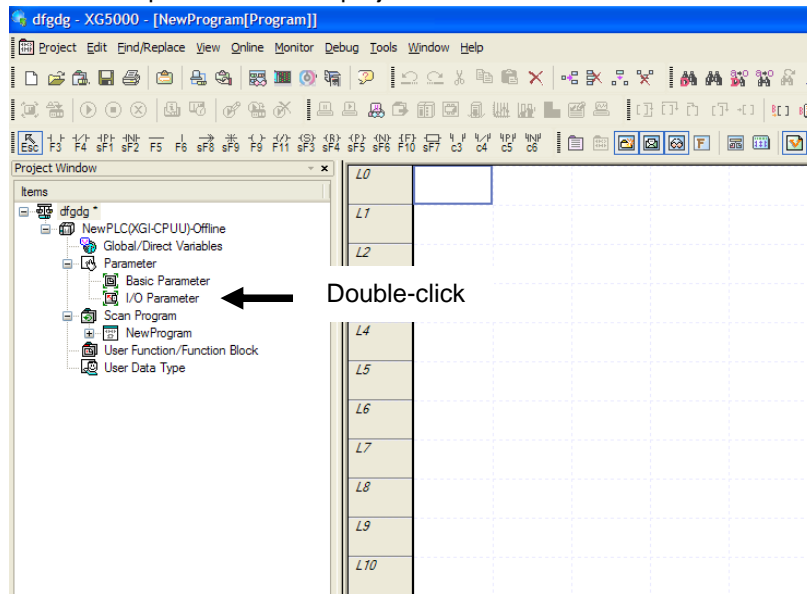

(b) Choose XGF-TC4RT module in the I/O parameter window.

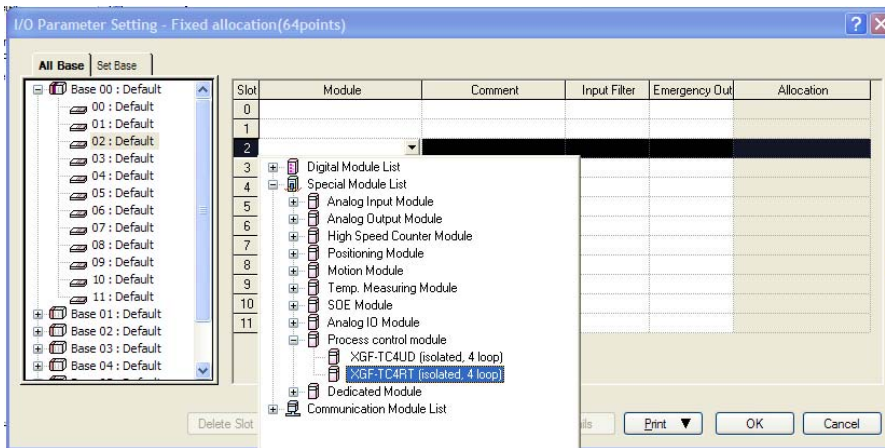

(d) Click on [Ok].

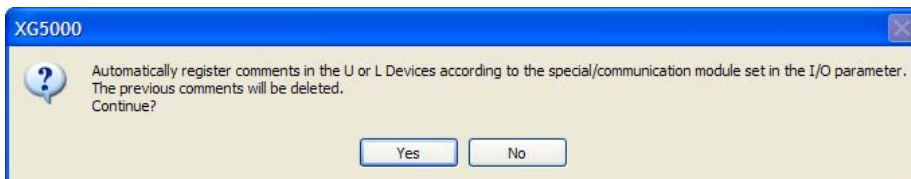

(e) Click on [Y].

- The global variable of the module set in I/O parameter is automatically registered.

Chapter 5 Configuration and Functions of Internal Memory (XGI/XGR)

(f) Check automatic registration of global variables.

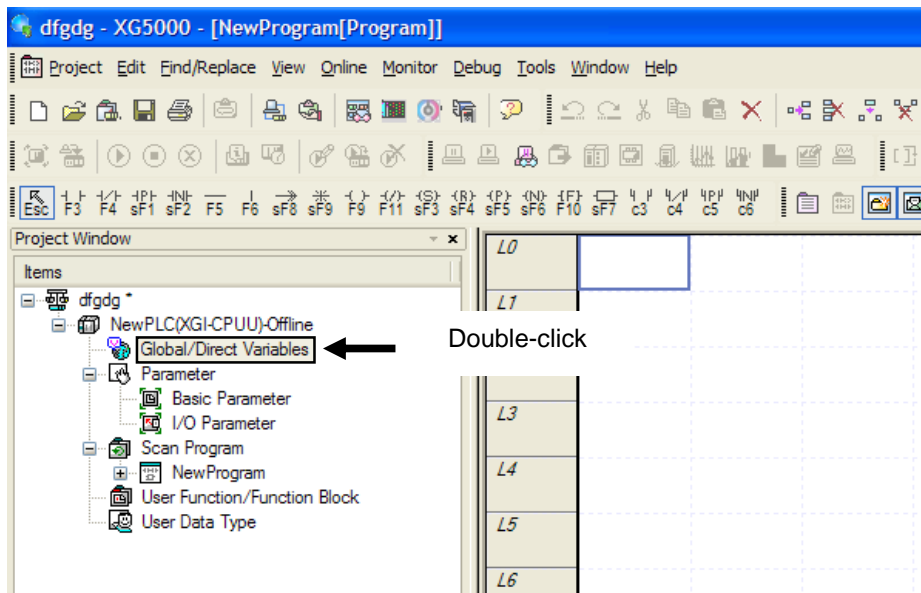

(g) Registered global variables

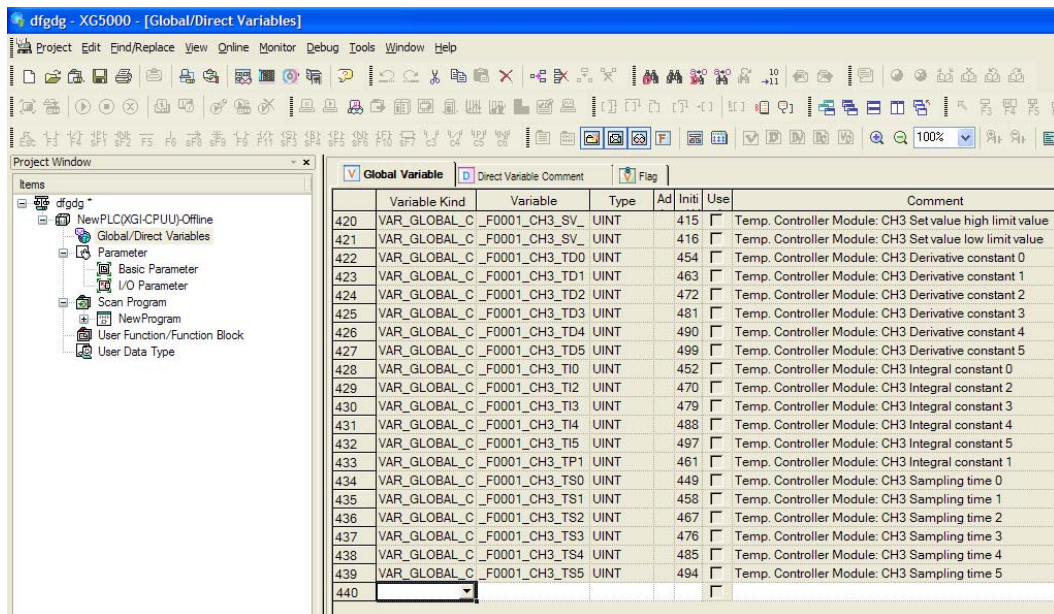

Chap. 5 Configuration and Functions of Internal Memory (XGI/XGR)

(2) Registration of global variables

- Register the global variable of the module set in I/O parameter.

(a) Double-click on the global/direct variables in the project window.

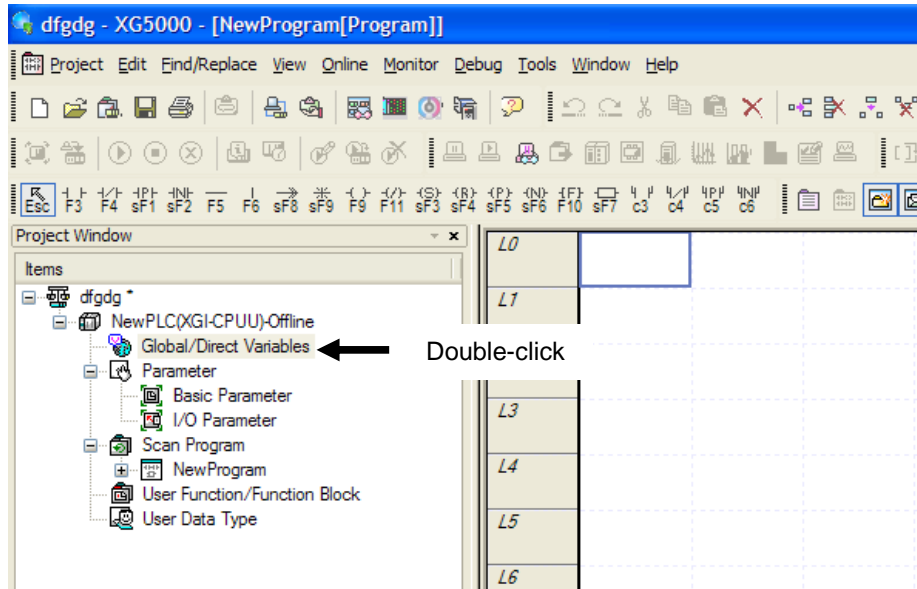

(b) Choose [Main menu]-[Edit]-[Automatic registration of special module variables].

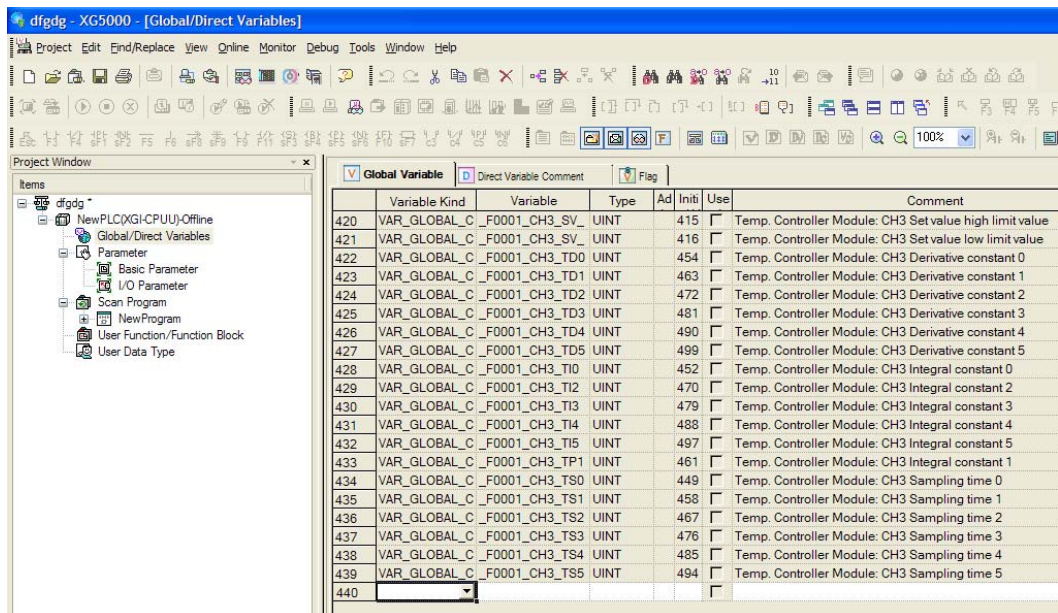

Chapter 5 Configuration and Functions of Internal Memory (XGI/XGR)

(3) Local variable registration

- Of the global variables registered in (b), the variable you want to use should be registered as the local variable.

(a) Double-click on the local variable of the program where you want to use the global variable in the scan program below.

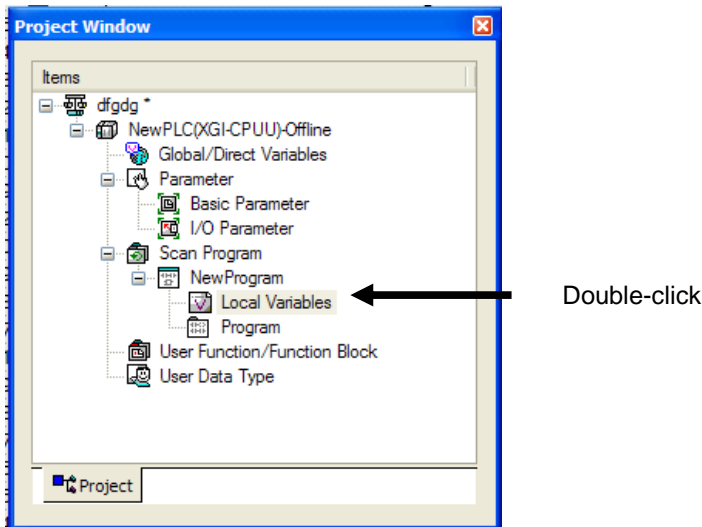

(b) Click the right button of the mouse in the local variable window on the right to choose “Add external variable.”

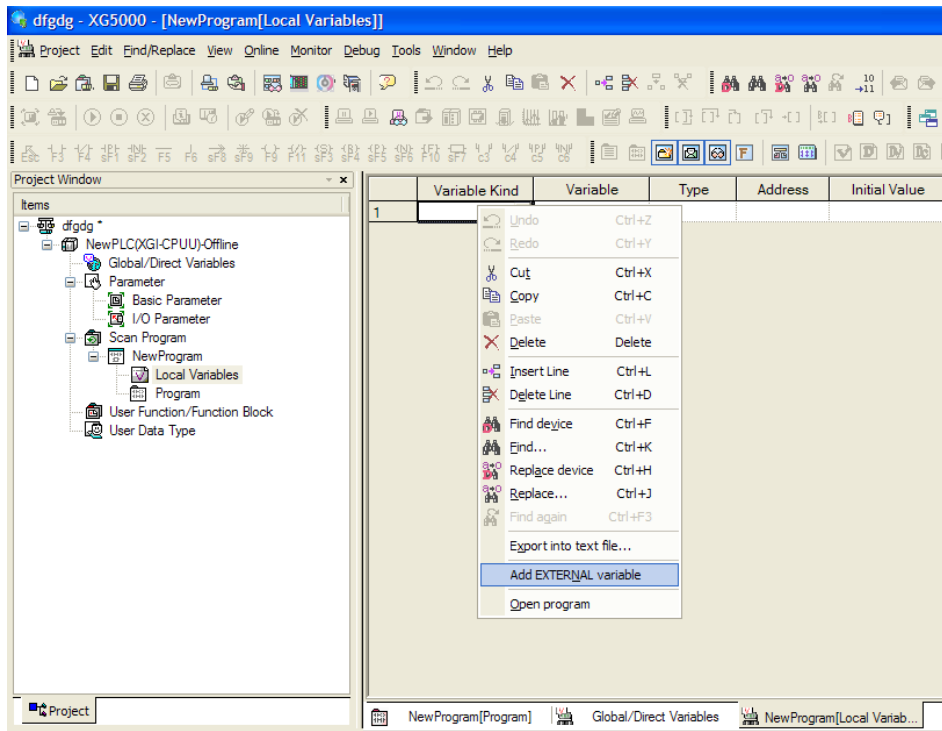

Chap. 5 Configuration and Functions of Internal Memory (XGI/XGR)

- (c) Check the variable you want to add in the “Add external variable” window below and choose [Ok].
 - The following is an example where auto-tuning command (_01_CH0_ATEN) of channel 0 and channel0 input value (_01_CH0_PV) have been chosen.

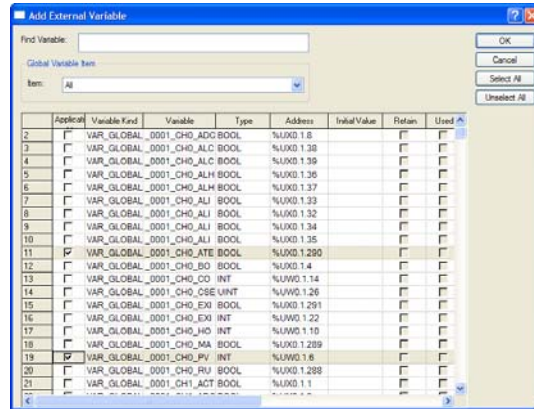

	Variable Kind	Variable	Type	Address	Initial Value	Retain	Used	Comment
1	VAR_EXTERNAL	_0001_CH0_ATE	BOOL	%UX0.1.290		<input type="checkbox"/>	<input type="checkbox"/>	Temp. Controller: CH0 auto-tuning c
2	VAR_EXTERNAL	_0001_CH0_PV	INT	%UW0.1.6		<input type="checkbox"/>	<input type="checkbox"/>	Temp. Controller: CH0 input value
3						<input type="checkbox"/>	<input type="checkbox"/>	
4						<input type="checkbox"/>	<input type="checkbox"/>	

- (4) How to use the local variable in the program
 - Adds the global variable added in (3) in the local program.
 (a) Put in the access point for starting auto-tuning in the ladder program as below, choose the coil, choose [Channel 0 auto-tuning command] in the variable selection window below and then click on Ok.

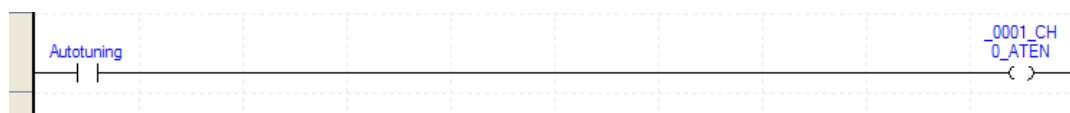
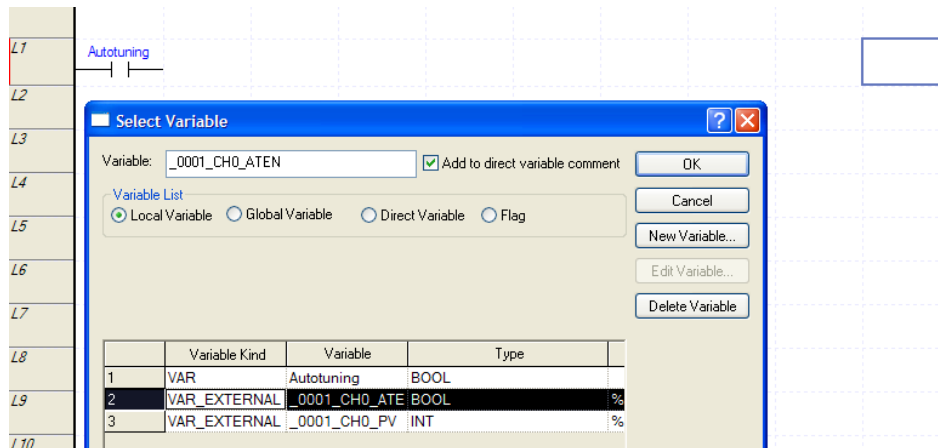

Chapter 5 Configuration and Functions of Internal Memory (XGI/XGR)

(b) As in (a), choose the input variable to move channel0 input value (_001_CH0_PV) to the %MO area by using the MOVE function.

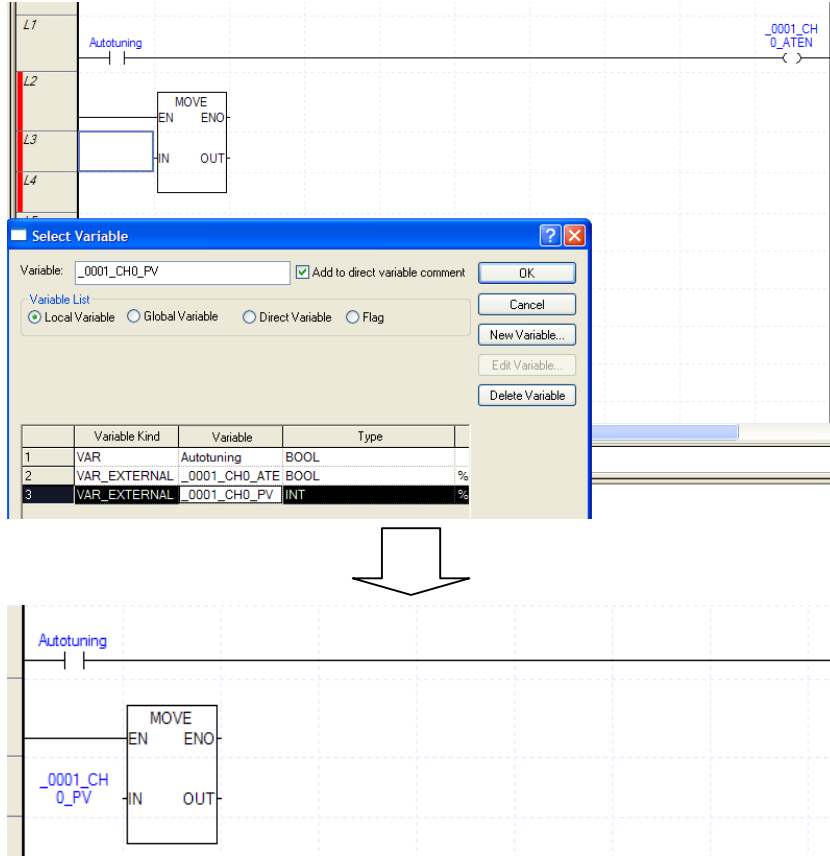

Chap. 5 Configuration and Functions of Internal Memory (XGI/XGR)

(c) Enter %MW0 as the output variable.

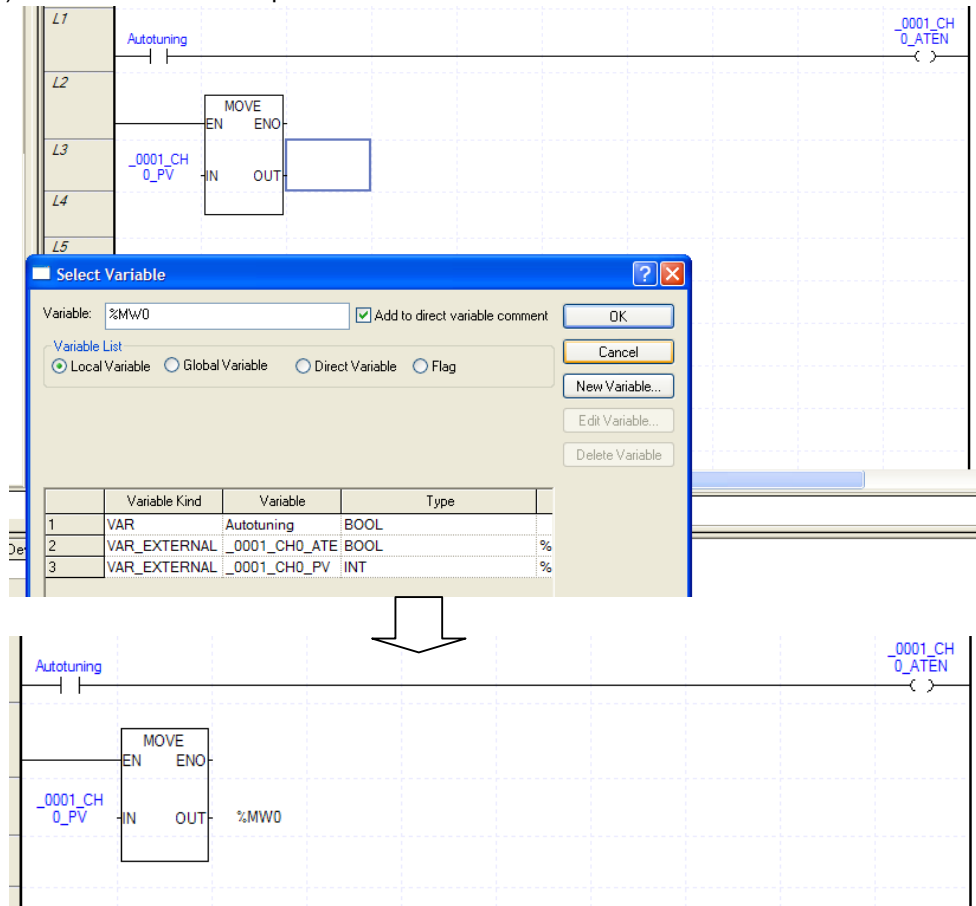

5.2 PUT/GET Function Block Area (Parameter Area)

5.2.1 PUT/GET Function Block Area (Parameter Area)

Table 5.2 shows the PUT/GET function block use area of the thermo-controller.

[Table 5. 2] PUT/GET function block area

Global variables	Read/Write	Type	Description
_Fxyy_CHn_STAT	Read	BIT	channel status
_Fxyy_CHn_IN	Read	INT	sensor input value
_Fxyy_CHn_SV	Read	INT	Current control target
_Fxyy_CHn_MV	Read	INT	control output value
_Fxyy_CHn_EV	Read	REAL	control error
_Fxyy_CHn_AT_STEP	Read	WORD	Auto-tuning step
_Fxyy_CHn_ERR	Read	WORD	channel error
_Fxyy_CHn_CTRL	Read/Write	BIT	channel command
_Fxyy_CHn_IN_PF	Read/Write	WORD	scale decimal point set value
_Fxyy_CHn_DB	Read/Write	WORD	Dead zone set value
_Fxyy_CHn_INP	Read/Write	BIT	input setting
_Fxyy_CHn_IN_TYPE	Read/Write	WORD	sensor code
_Fxyy_CHn_IN_SMAX	Read/Write	INT	scale upper limit set value
_Fxyy_CHn_IN_SMIN	Read/Write	INT	scale lower limit set value
_Fxyy_CHn_IN_MAX	Read/Write	INT	Effective input upper limit set value
_Fxyy_CHn_IN_MIN	Read/Write	INT	Effective input lower limit set value
_Fxyy_CHn_IN_HHAL	Read/Write	INT	input alarm further upper limit set value
_Fxyy_CHn_IN_HAL	Read/Write	INT	input alarm upper limit set value
_Fxyy_CHn_IN_LAL	Read/Write	INT	input alarm lower limit set value
_Fxyy_CHn_IN_LLAL	Read/Write	INT	input alarm further lower limit set value
_Fxyy_CHn_IN_CUT	Read/Write	WORD	LOWCUT set value
_Fxyy_CHn_IN_BIAS	Read/Write	INT	input BIAS set value
_Fxyy_CHn_IN_FILT	Read/Write	WORD	filter factor/average frequency set value
_Fxyy_CHn_IN_ALHYS	Read/Write	WORD	Alarm hysteresis set value
_Fxyy_CHn_CTP	Read/Write	BIT	control setting
_Fxyy_CHn_AT_SV	Read/Write	INT	auto-tuning target
_Fxyy_CHn_AT_HYS	Read/Write	WORD	auto-tuning hysteresis set value
_Fxyy_CHn_SV_MAX	Read/Write	INT	control target upper limit set value
_Fxyy_CHn_SV_MIN	Read/Write	INT	control target lower limit set value
_Fxyy_CHn_PV_TUP	Read/Write	WORD	rising PV tracking set value
_Fxyy_CHn_PV_TDN	Read/Write	WORD	falling PV tracking set value
_Fxyy_CHn_ONOF_HYS	Read/Write	WORD	ONOFF control hysteresis set value
_Fxyy_CHn_HC_RATE	Read/Write	INT	heating cooling proportional value
_Fxyy_CHn_H_PTIME	Read/Write	WORD	heating PWM cycle setting
_Fxyy_CHn_H_MAX	Read/Write	INT	heating output upper limit
_Fxyy_CHn_H_MIN	Read/Write	INT	heating output lower limit
_Fxyy_CHn_H_DMAX	Read/Write	WORD	heating output change upper limit
_Fxyy_CHn_H_REF	Read/Write	INT	heating output reference value
_Fxyy_CHn_H_EOUT	Read/Write	INT	failure heating output setting
_Fxyy_CHn_H_MAN	Read/Write	INT	heating manual output value
_Fxyy_CHn_H_HAL	Read/Write	INT	heating output upper limit alarm value
_Fxyy_CHn_H_LAL	Read/Write	INT	heating output lower limit alarm value
_Fxyy_CHn_C_PTIME	Read/Write	WORD	Cooling PWM cycle setting
_Fxyy_CHn_C_MAX	Read/Write	INT	Cooling output upper limit
_Fxyy_CHn_C_MIN	Read/Write	INT	Cooling output lower limit
_Fxyy_CHn_C_DMAX	Read/Write	WORD	Cooling output change upper limit
_Fxyy_CHn_C_REF	Read/Write	INT	Cooling output reference value
_Fxyy_CHn_C_EOUT	Read/Write	INT	Failure cooling output setting
_Fxyy_CHn_C_MAN	Read/Write	INT	Cooling manual output value
_Fxyy_CHn_C_HAL	Read/Write	INT	Cooling output upper limit alarm value

Chap. 5 Configuration and Functions of Internal Memory (XGI/XGR)

Global variables	Read/Write	Type	Description
_Fxyy_CHn_C_LAL	Read/Write	INT	Cooling output lower limit alarm value
_Fxyy_CHn_HC_ALHYS	Read/Write	WORD	output alarm common hysteresis value
_Fxyy_CHn_SV0	Read/Write	INT	target set value 0
_Fxyy_CHn_TS0	Read/Write	INT	cycle setting 0
_Fxyy_CHn_KP0	Read/Write	REAL	proportional factor set value 0
_Fxyy_CHn_TI0	Read/Write	REAL	integral factor set value 0
_Fxyy_CHn_TD0	Read/Write	REAL	differential factor set value 0
_Fxyy_CHn_BIAS0	Read/Write	INT	control BIAS set value 0
_Fxyy_CHn_SV1	Read/Write	INT	target set value 1
_Fxyy_CHn_TS1	Read/Write	INT	cycle setting 1
_Fxyy_CHn_KP1	Read/Write	REAL	proportional factor set value 1
_Fxyy_CHn_TP1	Read/Write	REAL	integral factor set value 1
_Fxyy_CHn_TD1	Read/Write	REAL	differential factor set value 1
_Fxyy_CHn_BIAS1	Read/Write	INT	control BIAS set value 1
_Fxyy_CHn_SV2	Read/Write	INT	target set value 2
_Fxyy_CHn_TS2	Read/Write	INT	cycle setting 2
_Fxyy_CHn_KP2	Read/Write	REAL	proportional factor set value 2
_Fxyy_CHn_TI2	Read/Write	REAL	integral factor set value 2
_Fxyy_CHn_TD2	Read/Write	REAL	differential factor set value 2
_Fxyy_CHn_BIAS2	Read/Write	INT	control BIAS set value 2
_Fxyy_CHn_SV3	Read/Write	INT	target set value 3
_Fxyy_CHn_TS3	Read/Write	INT	cycle setting 3
_Fxyy_CHn_KP3	Read/Write	REAL	proportional factor set value 3
_Fxyy_CHn_TI3	Read/Write	REAL	integral factor set value 3
_Fxyy_CHn_TD3	Read/Write	REAL	differential factor set value 3
_Fxyy_CHn_BIAS3	Read/Write	INT	control BIAS set value 3
_Fxyy_CHn_SV4	Read/Write	INT	target set value 4
_Fxyy_CHn_TS4	Read/Write	INT	cycle setting 4
_Fxyy_CHn_KP4	Read/Write	REAL	proportional factor set value 4
_Fxyy_CHn_TI4	Read/Write	REAL	integral factor set value 4
_Fxyy_CHn_TD4	Read/Write	REAL	differential factor set value 4
_Fxyy_CHn_BIAS4	Read/Write	INT	control BIAS set value 4
_Fxyy_CHn_SV5	Read/Write	INT	target set value 5
_Fxyy_CHn_TS5	Read/Write	INT	cycle setting 5
_Fxyy_CHn_KP5	Read/Write	REAL	proportional factor set value 5
_Fxyy_CHn_TI5	Read/Write	REAL	integral factor set value 5
_Fxyy_CHn_TD5	Read/Write	REAL	differential factor set value 5
_Fxyy_CHn_BIAS5	Read/Write	INT	control BIAS set value 5

Note) Read/Write is written based on PLC.

“n” of “~_CHn_~” indicates the channel and n= 0, 1, 2, 3.

5.2.2 PUT/GET function block

(1) PUT function block

PUT
Write data in special module

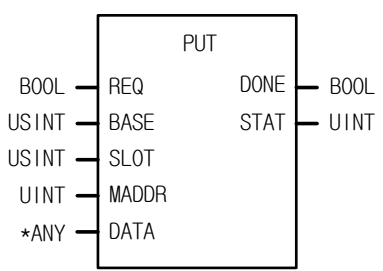
Function block	Description
 <pre> graph LR subgraph PUT REQ[REQ] BASE[BASE] SLOT[SLOT] MADDR[MADDR] DATA[DATA] DONE[DONE] STAT[STAT] end REQ --- DONE BASE --- STAT SLOT --- STAT MADDR --- STAT DATA --- STAT </pre>	<p>input REQ : Execute function when 1 BASE : Place base SLOT : Place slot MADDR : module address DATA : data to save in module</p> <p>output DONE : output of 1 during normal functioning STAT : error information</p>

*ANY: Of ANY Type, WORD, DWORD, INT, USINT, DINT, and UDINT Type are available.

■ Function

Read data from the special designated module.

Function block	input(ANY) Type	Description
PUT_WORD	WORD	Save WORD data in the designated module address (MADOR).
PUT_DWORD	DWORD	Save DWORD data in the designated module address (MADOR).
PUT_INT	INT	Save INT data in the designated module address (MADOR).
PUT_UINT	UINT	Save UINT data in the designated module address (MADOR).
PUT_DINT	DINT	Save DINT data in the designated module address (MADOR).
PUT_UDINT	UDINT	Save UDINT data in the designated module address (MADOR).

(2) GET function block

GET
Read special module data

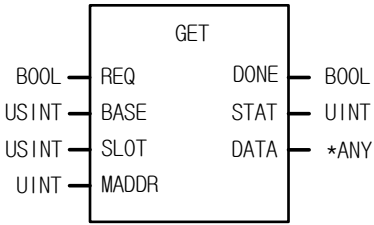
Function block	Description
 <pre> graph LR subgraph GET REQ[REQ] BASE[BASE] SLOT[SLOT] MADDR[MADDR] DONE[DONE] STAT[STAT] DATA[DATA] end REQ --- DONE BASE --- STAT SLOT --- DATA MADDR --- DATA </pre>	<p>input</p> <ul style="list-style-type: none"> REQ : Execute function when 1 BASE : Place base SLOT : Place slot MADDR : module address 512(0x200) ~ 1023(0x3FF) <p>output</p> <ul style="list-style-type: none"> DONE : output of 1 during normal functioning STAT : error information DATA : data read from module

*ANY: Of ANY Type, WORD, DWORD, INT, USINT, DINT, and UDINT Type are available.

■ Function

Read data from the designated special module.

Function block	input(ANY) Type	Description
GET_WORD	WORD	Read WORD data in the designated module address (MADOR).
GET_DWORD	DWORD	Read DWORD data in the designated module address (MADOR).
GET_INT	INT	Read INT data in the designated module address (MADOR).
GET_UINT	UINT	Read UINT data in the designated module address (MADOR).
GET_DINT	DINT	Read DINT data in the designated module address (MADOR).
GET_UDINT	UDINT	Read UDINT data in the designated module address (MADOR).

5.2.3 Example of Use of PUT/GET function block

(1) Example of use of PUT function block

- An example of registering the channel0 auto-tuning target variable in the order of registration of 6.2.1 Global variables and then using it in the local program.

(a) Bring channel0 auto-tuning target [_F0002_CH0_AT_SV] to the local variable window.

	Variable Kind	Variable	Type	Address	Initial Value	Retain	Used	Comment
1						<input type="checkbox"/>	<input type="checkbox"/>	
2	VAR_EXTERNAL_CONSTANT	_F0002_CH0_AT_SV	UINT		29	<input type="checkbox"/>	<input type="checkbox"/>	Temp. Controller Module: CH0 Set value on auto-tuning

(b) Add PUT_WORD function block to the local program and choose _F0002_CH0_AT_SV as the MADDR input variable.

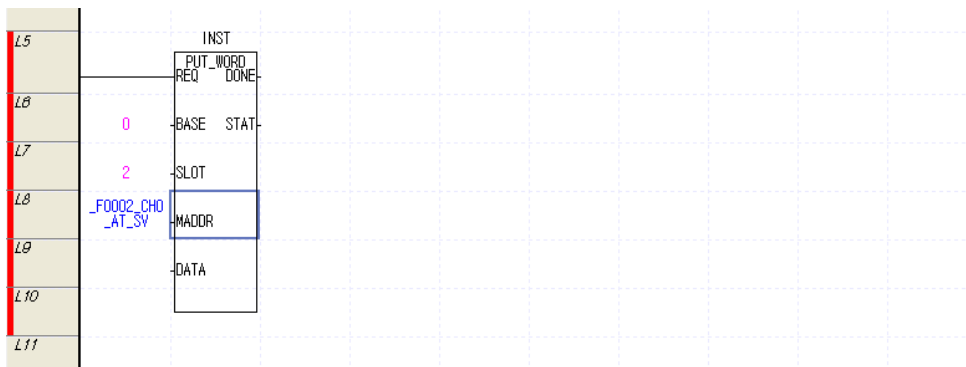

(c) Enter auto-tuning target as the data variable.

(Below is an example of entering 8000 as the target.)

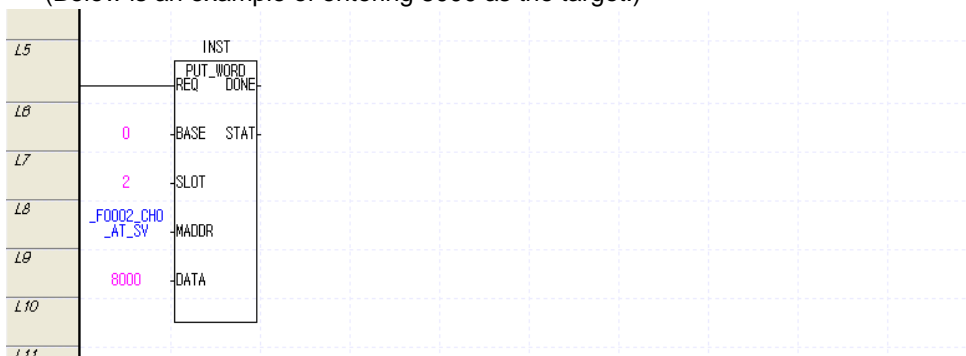

Chap. 5 Configuration and Functions of Internal Memory (XGI/XGR)

(2) Example of using the GET function block

- An example of registering the channel0 auto-tuning step variable in the order of registration of 6.2.1 Global variables and then using it in the local program

(a) Bring channel0 auto-tuning step [_F0002_CH0_AT_STEP] variable to the local variable window.

	Variable Kind	Variable	Type	Address	Initial Value	Retain	Used	Comment
1						<input type="checkbox"/>	<input type="checkbox"/>	
2	VAR_EXTERNAL_CONSTANT	_F0002_CH0_AT_SV	UINT		29	<input type="checkbox"/>	<input type="checkbox"/>	Temp. Controller Module: CH0 Set value on auto-tuning
3	VAR_EXTERNAL_CONSTANT	_F0002_CH0_AT_STEP	UINT		6	<input type="checkbox"/>	<input type="checkbox"/>	Temp. Controller Module: CH0 Auto-tuning step

(b) Add GET_WORD function block to the local program and choose _F0002_CH0_AT_STEP as the MADDR input variable.



(c) Designate the address to which you want to move the channel0 auto-tuning step value as the data variable.

(Below is an example of designating %MW100 to move the step.)

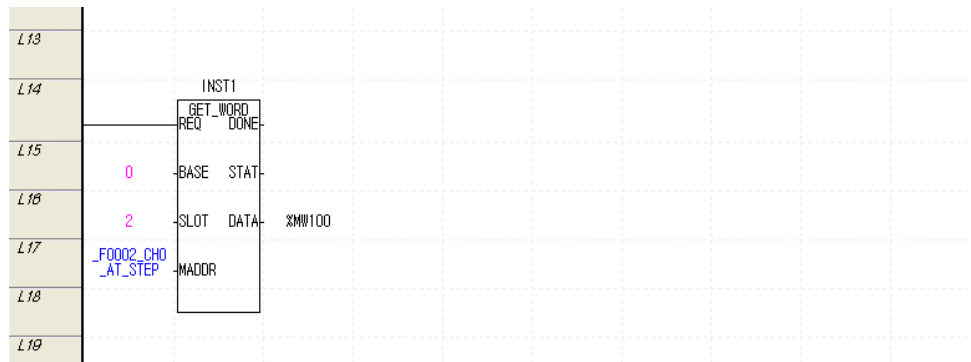

Chapter 6 Function

6.1 Input Parameter

This describes each item of input parameter of XG-TCON software to set up parameters. Following is the parameter set-up window.

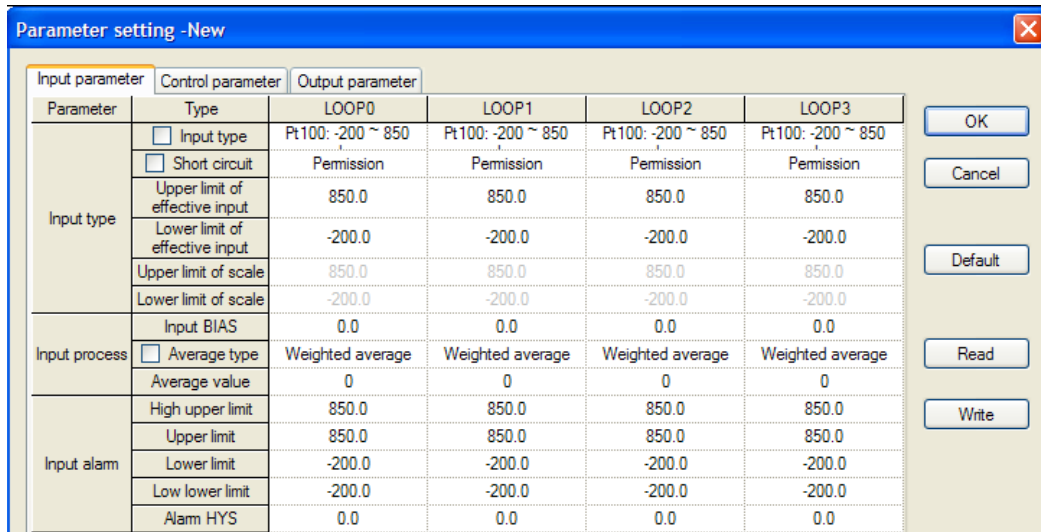

6.1.1 Type of input

(1) Type of input

The type of input can be set up through the software package or XG5000. It is selected from input type in case of software package, and set up by PUT command in case of XG5000.

Address (decimal number)				Name of symbol for XGI/XGR	Symbol	Description	Unit	Range	Initial value	Attribute
LOOP 0	LOOP 1	LOOP 2	LOOP 3							
14	142	270	398	_Fxyy_CHn_STAT	IN_TYPE	Select the type of input	None	13~15	13	Read/write

Table 3.1 Kinds of input

Kinds of input	Range of input	Setup value	Effective range of input	
			Lower limit (IN_MIN)	Upper limit (IN_MAX)
RTD	Pt100	-200.0~850.0	13	-200.0 ~ 850.0
	JPt100	-200.0~600.0	14	-200.0 ~ 600.0
	Pt1000	-200.0~850.0	15	-200.0 ~ 850.0

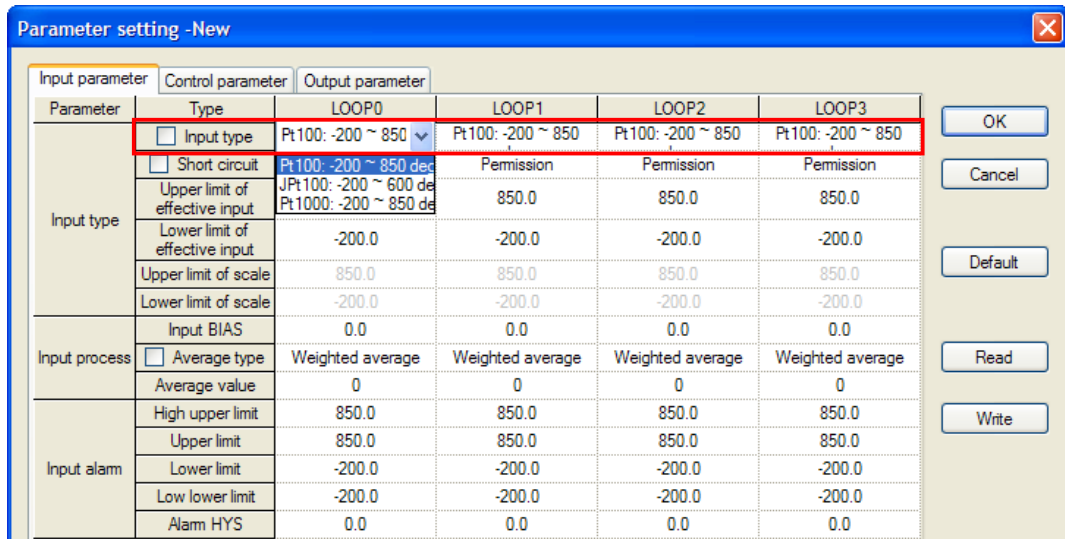

(2) Handling disconnection

The function to handle loop disconnection is the function to detect disconnection of sensor or input. If disconnection is detected, the measured input value is displayed as upper limit or lower limit, and the software package displays it as [cut-off] in the relevant loop sensor input. If you do not want to display [disconnection], then set up '0' at the address.

Address (decimal number)				Symbol for XGI/XGR	Symbol	Description	Unit	Range	Initial value	Attribute
LOOP 0	LOOP 1	LOOP 2	LOOP 3							
13.0	141.0	269.0	397.0	_Fxyy_CHn_INP	INP.CHK	Select a function to detect cutoff	None	0: prohibited 1: allowed	1	Read/write

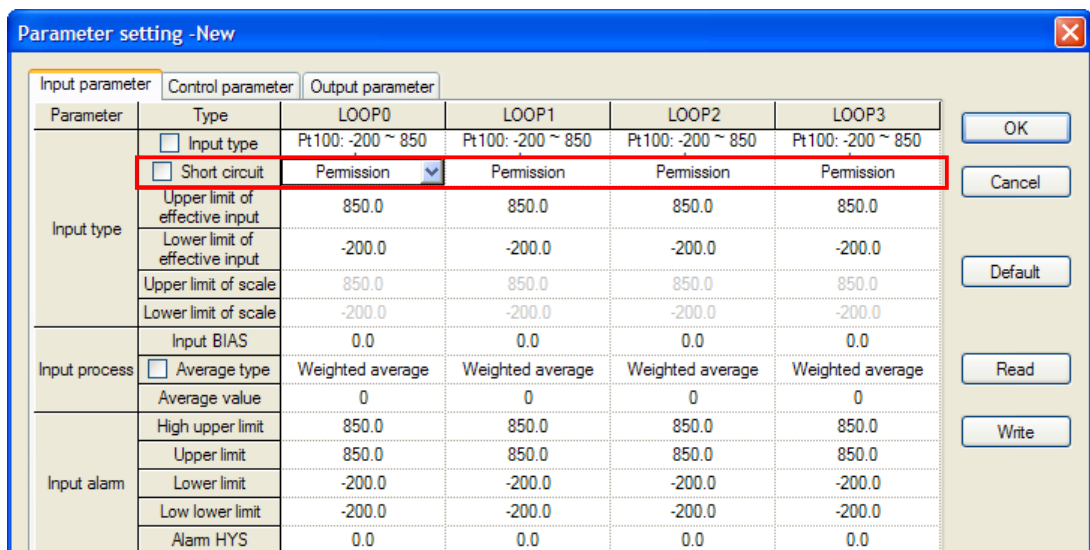

(3) Effective input upper limit/lower limit

The range to be used actually can be adjusted in the selected input range from input type. For example, from the input type PT100, -200 ~ 850 °C, if only using 0 ~ 800 °C input range, '800.0' is set as effective upper limit, and '0.0' is set as effective lower limit.

Address (Decimal number)				Symbol name for XGI/XGR	Symbol	Description	Unit	Range	Initial value	Attribute
LOOP 0	LOOP 1	LOOP 2	LOOP3							
18	146	274	402	_Fxyy_CHn_IN_MAX	IN_MAX	Effective input upper limit	°C	IN_MIN~IN_MAX	IN_MAX	Read/write
19	147	275	403	_Fxyy_CHn_IN_MIN	IN_MIN	Effective input lower limit	°C	IN_MIN~IN_MAX	IN_MIN	Read/write

Parameter	Type	LOOP0	LOOP1	LOOP2	LOOP3
Input type	<input type="checkbox"/> Input type	Pt100: -200 ~ 850	Pt100: -200 ~ 850	Pt100: -200 ~ 850	Pt100: -200 ~ 850
	<input type="checkbox"/> Short circuit	Permission	Permission	Permission	Permission
	Upper limit of effective input	80.0	850.0	850.0	850.0
	Lower limit of effective input	0.0	-200.0	-200.0	-200.0
	Upper limit of scale	850.0	850.0	850.0	850.0
	Lower limit of scale	-200.0	-200.0	-200.0	-200.0
Input process	<input type="checkbox"/> Average type	Weighted average	Weighted average	Weighted average	Weighted average
	Average value	0	0	0	0
Input alarm	High upper limit	850.0	850.0	850.0	850.0
	Upper limit	850.0	850.0	850.0	850.0
	Lower limit	-200.0	-200.0	-200.0	-200.0
	Low lower limit	-200.0	-200.0	-200.0	-200.0
	Alarm HYS	0.0	0.0	0.0	0.0

6.1.2 Input processing

(1) Input BIAS

The input BIAS function is to add/subtract certain value to/from the measured input value. If there is a difference between the measured value and the actual value, the BIAS function can compensate the difference. Also, if there is a deviation between loops for the same measured point, this function can correct it.

Address (Decimal number)				Symbol name for XGI/XGR	Symbol	Description	Unit	Range	Initial value	Attribute
LOOP 0	LOOP 1	LOOP 2	LOOP 3							
25	153	281	409	_Fxyy_CHn_IN_BIAS	IN_BIAS	Input BIAS Configuration value	Industrial Unit	-(IN_SMAX- IN_SMIN) ~ (IN_SMAX - IN_SMIN)	0	Read/write

Parameter	Type	LOOP0	LOOP1	LOOP2	LOOP3
Input type	<input type="checkbox"/> Input type	Pt100: -200 ~ 850	Pt100: -200 ~ 850	Pt100: -200 ~ 850	Pt100: -200 ~ 850
	<input type="checkbox"/> Short circuit	Permission	Permission	Permission	Permission
	Upper limit of effective input	80.0	850.0	850.0	850.0
	Lower limit of effective input	0.0	-200.0	-200.0	-200.0
	Lower limit of scale	-200.0	-200.0	-200.0	-200.0
Input process	<input checked="" type="checkbox"/> Input BIAS	0.0	0.0	0.0	0.0
	<input type="checkbox"/> Average type	Weighted average	Weighted average	Weighted average	Weighted average
Input alarm	Average value	0	0	0	0
	High upper limit	850.0	850.0	850.0	850.0
	Upper limit	850.0	850.0	850.0	850.0
	Lower limit	-200.0	-200.0	-200.0	-200.0
	Low lower limit	-200.0	-200.0	-200.0	-200.0
Alarm HYS	0.0	0.0	0.0	0.0	

(2) Weighted average

Weighted average processing function filters (delays) noise or rapid change of input value to earn stable digital output value. The constant of weighted average is available to be designated for every loop by user's program or input parameter configuration of XG-TCON.

Address (Decimal number)				Symbol name for XGI/XGR	Symbol	Description	Unit	Range	Initial value	Attribute
LOOP 0	LOOP 1	LOOP 2	LOOP 3							
13.2	141.2	269.2	397.2	_Fxyy_CHn_INP	INP.AVG	Average selection	None	0: Weighted average 1: Moving average	0	Read/write
26	154	282	410	_Fxyy_CHn_IN_FILT	IN_FILT	Average value	%	0 ~ 99	0 ¹	Read/write

¹ If it is not processed as average, then set it as 0.

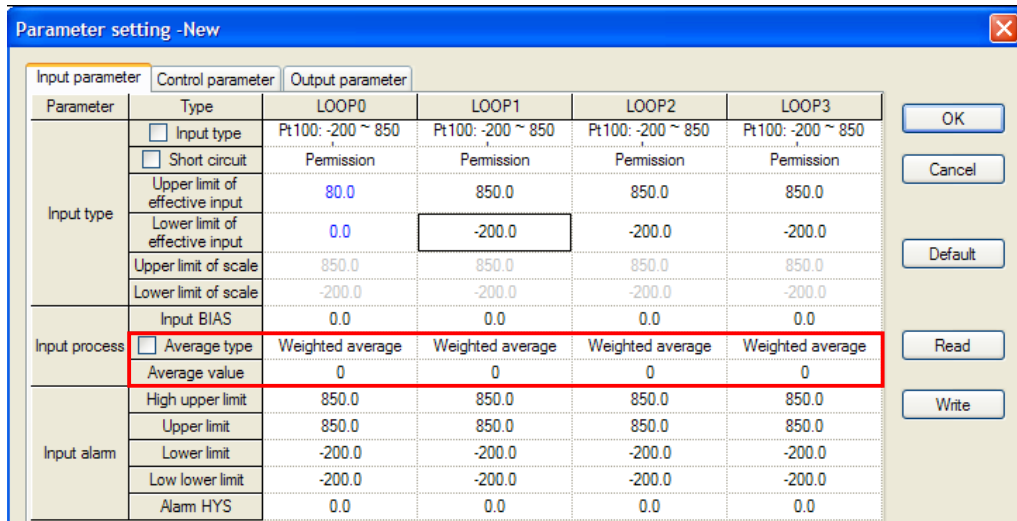

Configuration Range: 1 ~ 99(%)

$$F[n] = (1 - \alpha) \times A[n] + \alpha \times F[n - 1]$$

- F[n]: Current weighted average output value
- A[n]: Current input converted value
- F[n-1]: Previous Weighted average output value
- α: Weighted average constant (0.01 ~ 0.99: Weighted previous value)

- *1 If weighted average configuration value is not set up within 1 - 99, RUN LED is flashed by every one second. If you turn on the RUN LED, reconfigure the filter settings value within 1-99.
- *2 If the weighted average configuration value has error, the weighted average configuration value will be maintained at prior value.

(3) Moving average

Address (Decimal number)				Symbol name for XGI/XGR	Symbol	Description	Unit	Range	Initial value	Attribute
LOOP 0	LOOP 1	LOOP 2	LOOP 3							
13.2	141.2	269.2	397.2	_Fxxyy_CHn_INP	INP.AVG	Average selection	None	0: Weighted average 1: Moving average	0	Read/write
26	154	282	410	_Fxxyy_CHn_IN_FILT	IN_FILT	Average value	None	0 ~ 99	0 ²	Read/write

² If it is not processed as average, then set it as 0.

Parameter setting -New					
Input parameter		Output parameter			
Parameter	Type	LOOP0	LOOP1	LOOP2	LOOP3
Input type	<input type="checkbox"/> Input type	Pt100: -200 ~ 850	Pt100: -200 ~ 850	Pt100: -200 ~ 850	Pt100: -200 ~ 850
	<input type="checkbox"/> Short circuit	Permission	Permission	Permission	Permission
	Upper limit of effective input	80.0	850.0	850.0	850.0
	Lower limit of effective input	0.0	-200.0	-200.0	-200.0
	Upper limit of scale	850.0	850.0	850.0	850.0
	Lower limit of scale	-200.0	-200.0	-200.0	-200.0
Input process	<input type="checkbox"/> Average type	Moving average	Weighted average	Weighted average	Weighted average
	Average value	0	0	0	0
Input alarm	High upper limit	850.0	850.0	850.0	850.0
	Upper limit	850.0	850.0	850.0	850.0
	Lower limit	-200.0	-200.0	-200.0	-200.0
	Low lower limit	-200.0	-200.0	-200.0	-200.0
	Alarm HYS	0.0	0.0	0.0	0.0

(a) Configuration Range: 2 ~ 99(times)

(b) The input converted value is saved in the memory after sampling with the number designated by the range of configuration. Then, the average of the saved sampling data is calculated. As the newest sampling input converted value comes into the memory, the oldest sampling input converted data is discarded for calculating average. Figure 2.3 shows the moving average configured by 4.

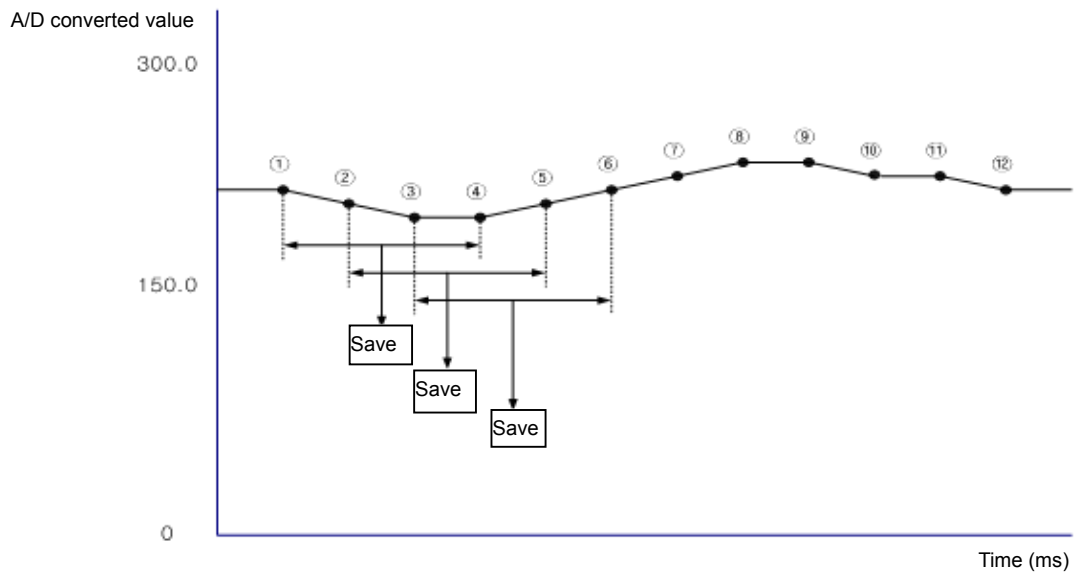

[Figure 2.1] Moving average

$$\text{Save 1} = (\textcircled{1} + \textcircled{2} + \textcircled{3} + \textcircled{4}) / 4$$

$$\text{Save 2} = (\textcircled{2} + \textcircled{3} + \textcircled{4} + \textcircled{5}) / 4$$

$$\text{Save 3} = (\textcircled{3} + \textcircled{4} + \textcircled{5} + \textcircled{6}) / 4$$

6.2 Control Parameter

The temperature controller module realizes PID control in performing the control. PID control is abbreviation of Proportional, Integral and Differential Control. It is the control technique that compares the control target and current state of the system, and adjusts energy supplied to the system through mathematical computation including proportion, integral calculus, and differential calculus to stabilize the system to the control target. Generally, the largest goal of the control function is how to correct and stabilize the control target in a short time. In order to fulfill this goal, the input and output environment of the control system is composed, and basically, the control target and P, I, D coefficient should be configured to fit to the feature of the system. And then, various additional functions are configured by considering the system to complete the control system. Therefore, the control part is connected as shown below with the input part and output part.

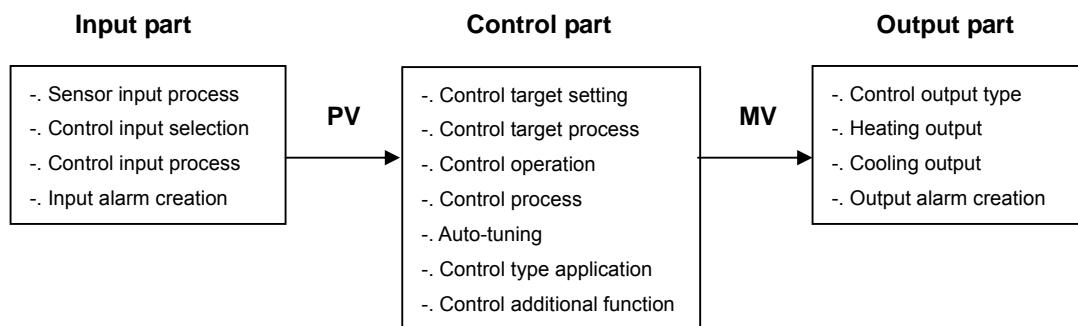

6.2.1 Configuration of the control target

Address (Decimal number)				Symbol name for XGI/XGR	Symbol	Description	Unit	Range	Initial value	Attribute
LOOP 0	LOOP 1	LOOP 2	LOOP 3							
64	192	320	448	_Fxyy_CHn_SV0	SV0	SV[Control target] 0	PVUnit	SVlower limit-SVupper limit	0	Read/write
73	201	329	457	_Fxyy_CHn_SV1	SV1	SV[Control target] 1	PVUnit	SVlower limit-SVupper limit	0	Read/write
82	210	338	466	_Fxyy_CHn_SV2	SV2	SV[Control target] 2	PVUnit	SVlower limit-SVupper limit	0	Read/write
91	219	347	475	_Fxyy_CHn_SV3	SV3	SV[Control target] 3	PVUnit	SVlower limit-SVupper limit	0	Read/write
100	228	356	484	_Fxyy_CHn_SV4	SV4	SV[Control target] 4	PVUnit	SVlower limit-SVupper limit	0	Read/write
109	237	365	493	_Fxyy_CHn_SV5	SV5	SV[Control target] 5	PVUnit	SVlower limit-SVupper limit	0	Read/write

Parameter setting -New						
Input parameter	Control parameter	Output parameter				
Parameter	Type	LOOP0	LOOP1	LOOP2	LOOP3	
AT start	Autotuning of SV	0.0	0.0	0.0	0.0	OK
	Autotuning of HYS	0.0	0.0	0.0	0.0	Cancel
Target setting	SV Upper limit	850.0	850.0	850.0	850.0	Default
	SV Lower limit	-200.0	-200.0	-200.0	-200.0	
	PV Rising trackings	0.0	0.0	0.0	0.0	
	PV Falling trackings	0.0	0.0	0.0	0.0	
Control setting	<input type="checkbox"/> Control type	PID	PID	PID	PID	Read
	On/Off control HYS	0.0	0.0	0.0	0.0	
	<input type="checkbox"/> Forward/Reverse division	Forward operation	Forward operation	Forward operation	Forward operation	
	Dead Band	0.0	0.0	0.0	0.0	
	<input type="checkbox"/> Antiwindup	Setting	Setting	Setting	Setting	
	<input type="checkbox"/> Prevent the shock from manual operation changing	Permission	Permission	Permission	Permission	
	<input type="checkbox"/> Proportional operation source	EV	EV	EV	EV	
	<input type="checkbox"/> Differential operation source	PV	PV	PV	PV	
Control coefficient	SV(Set value)	-200.0	-200.0	-200.0	-200.0	Write
	Ts(Control period)	0	0	0	0	
	Kp(Propotional coefficients)	0.000	0.000	0.000	0.000	
	Ti(Integral coefficients)	0.000	0.000	0.000	0.000	
	Td(Differential coefficients)	0.000	0.000	0.000	0.000	
	Control BIAS	0	0	0	0	

The control target is usually called as SV (Set point value). It can be said that it is a numerical expression of the state where the control system is stable. For example, if you want to set the system temperature 30 °C, then 30 will be the control target. This value has same unit with the value measured by sensor. If the sensor measure 30 °C as 3000, the control target will also be 3000. Once the control target is set, PID CONTROLLER unlimitedly repeat the control calculation until the system status becomes equal to SV.

Since temperature controller supports 6 control sets, six kinds of control targets can be configured and converted.

6.2.2 Address the control target

(1) SV upper limit/lower limit configuration

Address (Decimal number)				Symbol name for XGI/XGR	Symbol	Description	Unit	Range	Initial value	Attribute
LOOP 0	LOOP 1	LOOP 2	LOOP 3							
31	159	287	415	_Fxyy_CHn_SV_MAX	SV_MAX	SV upper limit	PV Unit	SVlower limit~PVupper limit	0	Read/write
32	160	288	416	_Fxyy_CHn_SV_MIN	SV_MIN	SV lower limit	PV Unit	PVlower limit~SVupper limit	0	Read/write

The screenshot shows a 'Parameter setting -New' window with the 'Control parameter' tab selected. The 'Target setting' section is highlighted with a red box, indicating the configuration for the SV upper and lower limits. The values are 850.0 for the upper limit and -200.0 for the lower limit across all four loops (LOOP0, LOOP1, LOOP2, LOOP3). Other parameters like 'Control type' (PID) and 'Control coefficient' (Kp, Ti, Td) are also visible.

As described above, since the control target is the state of system that the user wants, if the user wants, he/she may change the control target. In order to prevent error occurred during the changing control target, the SV / lower limit value can be configured. By blocking the status where it cannot be physically reached or which is difficult, it can block error even when multiple users use it together. The control target is limited by the SV / lower limit value.

(2) PV rising/falling tracking

Address (Decimal number)				Symbol name for XGI/XGR	Symbol	Description	Unit	Range	Initial value	Attribute
LOOP 0	LOOP 1	LOOP 2	LOOP 3							
33	161	289	417	_Fxyy_CHn_PV_TUP	PV_TUP	PV rising tracking	PV Unit	0~10000	0	Read/write
34	162	290	418	_Fxyy_CHn_PV_TDN	PV_TDN	PV falling tracking	PV Unit	0~10000	0	Read/write

Parameter setting -New							
Input parameter	Control parameter	Output parameter					
Parameter	Type	LOOP0	LOOP1	LOOP2	LOOP3		
AT start	Autotuning of SV	0.0	0.0	0.0	0.0	OK	
	Autotuning of HYS	0.0	0.0	0.0	0.0	Cancel	
Target setting	SV Upper limit	850.0	850.0	850.0	850.0	Default	
	SV Lower limit	-200.0	-200.0	-200.0	-200.0		
	PV Rising trackings	0.0	0.0	0.0	0.0		
	PV Falling trackings	0.0	0.0	0.0	0.0		
Control setting	<input type="checkbox"/> Control type	PID	PID	PID	PID	Read	
	<input type="checkbox"/> On/Off control HYS	0.0	0.0	0.0	0.0		
	<input type="checkbox"/> Forward/Reverse division	Forward operation	Forward operation	Forward operation	Forward operation		
	Dead Band	0.0	0.0	0.0	0.0		
	<input type="checkbox"/> Antiwindup	Setting	Setting	Setting	Setting		
	<input type="checkbox"/> Prevent the shock from manual operation changing	Permission	Permission	Permission	Permission		
	<input type="checkbox"/> Proportional operation source	EV	EV	EV	EV		
	<input type="checkbox"/> Differential operation source	PV	PV	PV	PV		
	SV(Set value)	-200.0	-200.0	-200.0	-200.0		Write
	Ts(Control period)	0	0	0	0		
Kp(Proportional coefficients)	0.000	0.000	0.000	0.000			
Ti(Integral coefficients)	0.000	0.000	0.000	0.000			
Control coefficient	Td(Differential coefficients)	0.000	0.000	0.000	0.000		
	Control BIAS	0	0	0	0		

If the difference between SV and PV is significant, large output may affect the operator of the system adversely. At this time, PV tracking function generates dynamic SV by temporarily matching SV to around PV to increase output of the operator to smoothly bring PV to the target. PV upward tracking is operated in the PV upward zone, and PV downward tracking is operated in PV downward zone. The configured value is used at tracking interval.

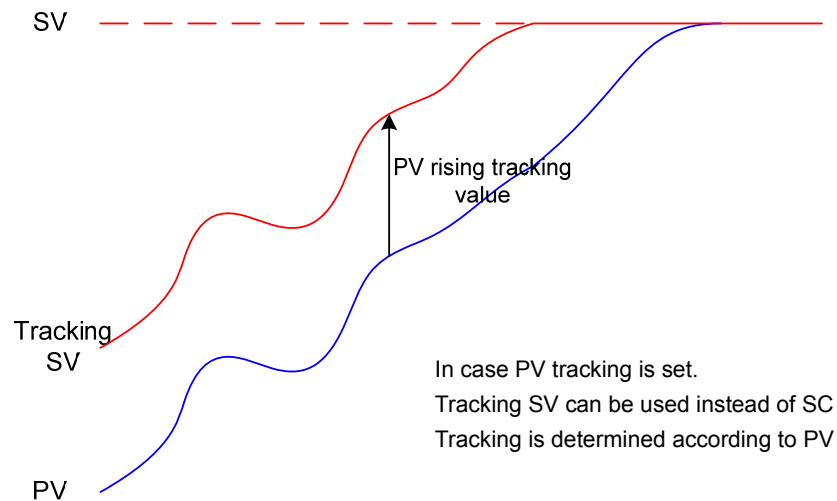

6.2.3 Control type

The control types supported by temperature controller are PID and ON-OFF calculation. Each calculation applies to control type according to the configured code.

Address (Decimal number)				Symbol name for XGI/XGR	Symbol	Description	Unit	Range	Initial value	Attribute
LOOP 0	LOOP 1	LOOP 2	LOOP 3							
10.4~5	138.4~5	266.4~5	385.4~5	_Fxyy_CHn_CTRL	CTRL.TYPE	Control type	code	0 : PID 2 : ONOFF	0	Read/write

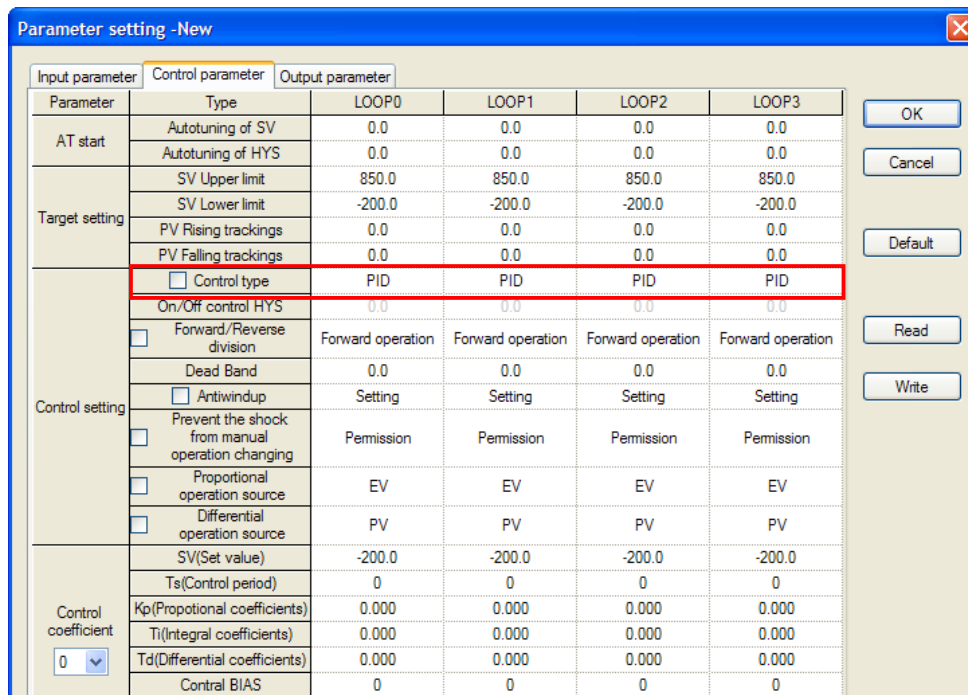

(1) PID CONTROL

The table below is the description of the each control coefficient related to PID CONTROL.

Address (Decimal number)				Symbol name for XGI/XGR	Symbol	Description	Unit	Range	Initial value	Attribute
LOOP 0	LOOP 1	LOOP 2	LOOP 3							
65	193	321	449	_Fxyy_CHn_TS0	TS0	TS[Control cycle] 0	200ms	0~65535 (x 200ms)	0	Read/write
74	202	330	458	_Fxyy_CHn_TS1	TS1	TS[Control cycle] 1	200ms	0~65535 (x 200ms)	0	Read/write
83	211	339	467	_Fxyy_CHn_TS2	TS2	TS[Control cycle] 2	200ms	0~65535 (x 200ms)	0	Read/write
92	220	348	476	_Fxyy_CHn_TS3	TS3	TS[Control cycle] 3	200ms	0~65535 (x 200ms)	0	Read/write
101	229	357	485	_Fxyy_CHn_TS4	TS4	TS[Control cycle] 4	200ms	0~65535 (x 200ms)	0	Read/write

Address (Decimal number)				Symbol name for XGI/XGR	Symbol	Description	Unit	Range	Initial value	Attribute
LOOP 0	LOOP 1	LOOP 2	LOOP 3							
110	238	366	494	_Fxyy_CHn_TS5	TS5	TS[Control cycle] 5	200ms	0~65535 (x 200ms)	0	Read/write
66	194	322	450	_Fxyy_CHn_KP0	KP0	KP[Proportional coefficient] 0	MV/PV	0~10000	0	Read/write
75	203	331	459	_Fxyy_CHn_KP1	KP1	KP[Proportional coefficient] 1	MV/PV	0~10000	0	Read/write
84	212	340	468	_Fxyy_CHn_KP2	KP2	KP[Proportional coefficient] 2	MV/PV	0~10000	0	Read/write
93	221	349	477	_Fxyy_CHn_KP3	KP3	KP[Proportional coefficient] 3	MV/PV	0~10000	0	Read/write
102	230	358	486	_Fxyy_CHn_KP4	KP4	KP[Proportional coefficient] 4	MV/PV	0~10000	0	Read/write
111	239	367	495	_Fxyy_CHn_KP5	KP5	KP[Proportional coefficient] 5	MV/PV	0~10000	0	Read/write
68	196	324	452	_Fxyy_CHn_TI0	TI0	TI[Integrated coefficient] 0	second	0~10000	0	Read/write
77	204	333	461	_Fxyy_CHn_TI1	TI1	TI[Integrated coefficient] 1	second	0~10000	0	Read/write
86	214	342	470	_Fxyy_CHn_TI2	TI2	TI[Integrated coefficient] 2	second	0~10000	0	Read/write
95	223	351	479	_Fxyy_CHn_TI3	TI3	TI[Integrated coefficient] 3	second	0~10000	0	Read/write
104	232	360	488	_Fxyy_CHn_TI4	TI4	TI[Integrated coefficient] 4	second	0~10000	0	Read/write
113	241	369	497	_Fxyy_CHn_TI5	TI5	TI[Integrated coefficient] 5	second	0~10000	0	Read/write
70	198	326	454	_Fxyy_CHn_TD0	TD0	TD[Differential coefficient] 0	second	0~10000	0	Read/write
79	206	335	463	_Fxyy_CHn_TD1	TD1	TD[Differential coefficient] 1	second	0~10000	0	Read/write
88	216	344	472	_Fxyy_CHn_TD2	TD2	TD[Differential coefficient] 2	second	0~10000	0	Read/write
97	225	353	481	_Fxyy_CHn_TD3	TD3	TD[Differential coefficient] 3	second	0~10000	0	Read/write
106	234	362	490	_Fxyy_CHn_TD4	TD4	TD[Differential coefficient] 4	second	0~10000	0	Read/write
115	243	371	499	_Fxyy_CHn_TD5	TD5	TD[Differential coefficient] 5	second	0~10000	0	Read/write
72	200	328	456	_Fxyy_CHn_BIAS0	BIAS0	Control BIAS 0	PVUnit	-10000~10000	0	Read/write
81	208	337	465	_Fxyy_CHn_BIAS1	BIAS0	Control BIAS 1	PVUnit	-10000~10000	0	Read/write
90	218	346	474	_Fxyy_CHn_BIAS2	BIAS0	Control BIAS 2	PVUnit	-10000~10000	0	Read/write
99	227	355	483	_Fxyy_CHn_BIAS3	BIAS0	Control BIAS 3	PVUnit	-10000~10000	0	Read/write
108	236	364	492	_Fxyy_CHn_BIAS4	BIAS0	Control BIAS 4	PVUnit	-10000~10000	0	Read/write
117	245	373	501	_Fxyy_CHn_BIAS5	BIAS0	Control BIAS 5	PVUnit	-10000~10000	0	Read/write

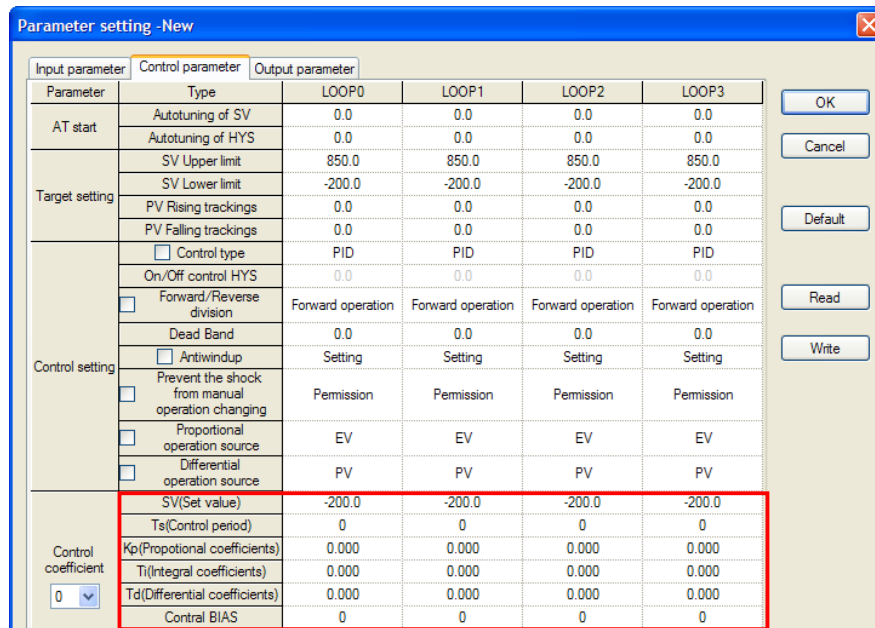

PID CALCULATION (or single PID) is a structure where P, I, and D are calculated and summed up. The terminologies to explain the PID CONTROL calculation are as follows.

- T_s(Ts) : Sampling time (Control cycle)
- K_p(Kp) : Proportional coefficient.
- T_i(Ti) : Constant of integral calculation
- T_d(Td) : Constant of differential calculation
- SV : Target status where the controlled object should reach
- PV : Detect the status of currently controlled object through sensor
- EV : Error of currently controlled object (SV -PV)
- MV : Control input or controller output.
- MV_p(MVp) : Proportional component of MV
- MV_i(MVi) : Integral component of MV
- MV_d(MVD) : Differential component of MV
- Bias : Control BIAS

The calculation formula of PID CONTROL is as follows.

$$EV = SV - PV \quad (7.4.1)$$

$$MV_p = K_p EV \quad (7.4.2)$$

$$MV_i = \frac{K_p}{T_i} \int EV dt \quad (7.4.3)$$

$$MV_d = K_p T_d \frac{dEV}{dt} \quad (7.4.4)$$

$$MV = MV_p + MV_i + MV_d + Bias \quad (7.4.5)$$

Since the formula above includes integral term and differential term, it is difficult to interpret it. But from the conceptual approach, P calculation is the result of multiplying control error EV and Kp, and in case of I calculation, it is the result of adding the result of P calculation for every cycle and dividing it by Ti. Therefore, the smaller Ti is, the wider the width of integral is. Finally, the D calculation multiplies Td to the change volume of the result of the cycle P calculation. These three components results are summed up as shown in the formula (7.4.5), and the Control BIAS is added to generate the MV.

(2) ON/OFF control

Address (Decimal number)				Symbol name for XGI/XGR	Symbol	Description	Unit	Range	Initial value	Attribute
LOOP 0	LOOP 1	LOOP 2	LOOP 3							
35	163	291	419	_Fxyy_CHn_ONOF_HYS	ONOF_HYS	ON-OFF control hysteresis	PV Unit	0~10000	0	Read/write

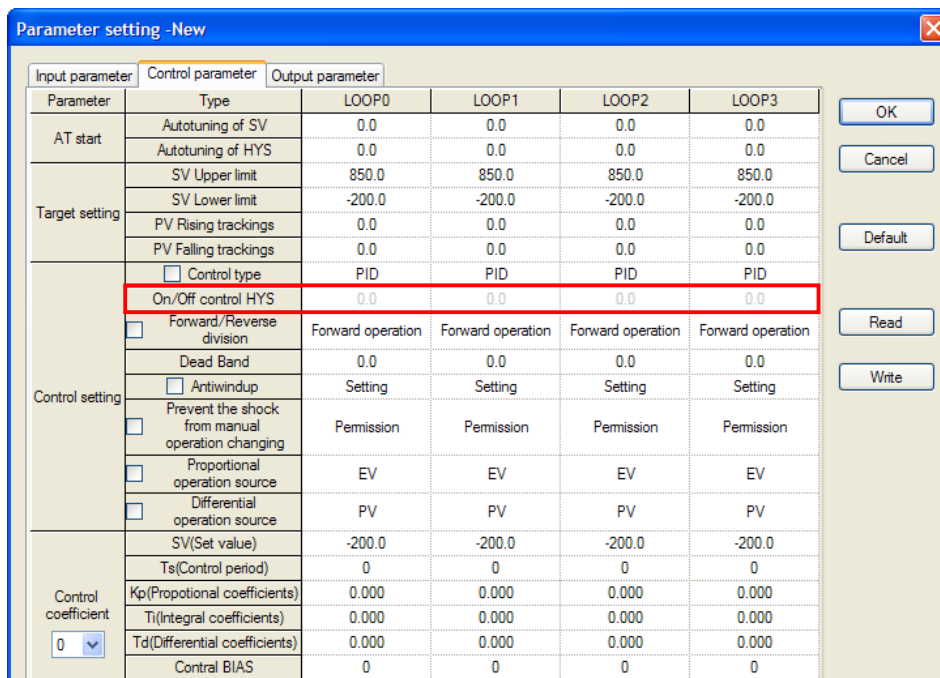

In case of forward action, from SV configured by a user as criteria, On-Off calculation turns on MV if PV is less than SV, and turns off MV if PV is more than SV. It is like a heater which is turned on if it is cold, and turned off if it is warm. On-Off hysteresis applies here to filter the noise of sensor which measures PV. Moreover, MV exists as On and Off in On-Off calculation. If it is On, the maximum value is out, and if it is Off, the minimum value is out in case of temperature controller. The On-Off calculation is like as shown below.

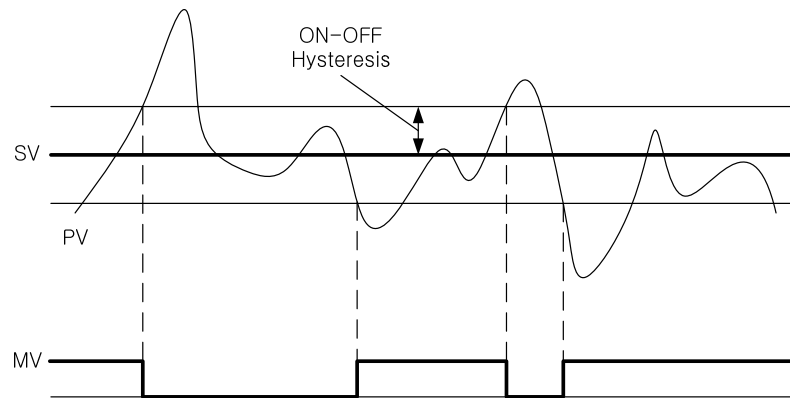

6.2.4 Control processing technique

Let's look into the control processing technique additionally supported besides the basic control calculation function of the temperature controller as aforementioned.

(1) Forward action and reverse action

Address (Decimal number)				Symbol name for XGI/XGR	Symbol	Description	Unit	Range	Initial value	Attribute
LOOP 0	LOOP 1	LOOP 2	LOOP 3							
10.0	138.0	266.0	385.0	_Fxyy_CHn_CTRL	CTRL.REV	Forward/reverse	code	0 : Forward action 1 : reverse action	0	Read/write

Parameter setting - New

Input parameter | **Control parameter** | Output parameter

Parameter	Type	LOOP0	LOOP1	LOOP2	LOOP3
AT start	Autotuning of SV	0.0	0.0	0.0	0.0
	Autotuning of HYS	0.0	0.0	0.0	0.0
Target setting	SV Upper limit	850.0	850.0	850.0	850.0
	SV Lower limit	-200.0	-200.0	-200.0	-200.0
	PV Rising trackings	0.0	0.0	0.0	0.0
	PV Falling trackings	0.0	0.0	0.0	0.0
Control setting	<input type="checkbox"/> Control type	PID	PID	PID	PID
	On/Off control HYS	0.0	0.0	0.0	0.0
	<input type="checkbox"/> Forward/Reverse division	Forward operation	Forward operation	Forward operation	Forward operation
	Dead Band	0.0	0.0	0.0	0.0
	<input type="checkbox"/> Antiwindup	Setting	Setting	Setting	Setting
	<input type="checkbox"/> Prevent the shock from manual operation changing	Permission	Permission	Permission	Permission
	<input type="checkbox"/> Proportional operation source	EV	EV	EV	EV
<input type="checkbox"/> Differential operation source	PV	PV	PV	PV	
Control coefficient	SV(Set value)	-200.0	-200.0	-200.0	-200.0
	Ts(Control period)	0	0	0	0
	Kp(Proportional coefficients)	0.000	0.000	0.000	0.000
	Ti(Integral coefficients)	0.000	0.000	0.000	0.000
	Td(Differential coefficients)	0.000	0.000	0.000	0.000
	Control BIAS	0	0	0	0

Buttons: OK, Cancel, Default, Read, Write

According to the characteristic of system, it can be divided into the case to control forward action, and control reverse action. Since there is no specific standard that which control is a basis, users should be aware of the Forward action by manufacturers and models. In case of temperature controller, the forward action and reverse action control are defined as follows.

Forward action system: If control **output(MV) rises**, the **status indicator(PV) rises**

Reverse action system: If control **output(MV) rises**, the **status indicator(PV) decreases**

Good examples of forward action and reverse action are heater and cooler. If the control output delivered to the heater rises, then more heat is generated to raise temperature. So heating system is a forward action system. On the contrary, if the control output delivered to cooler rises, then more cooling is generated to lower the temperature. So cooling system is reverse action system.

Therefore, according to the characteristic of the system, you should adjust the forward action, reverse action configuration correctly.

(2) Dead zone (operated by configured value)

Address (Decimal number)				Symbol name for XGI/XGR	Symbol	Description	Unit	Range	Initial value	Attribute
LOOP 0	LOOP 1	LOOP 2	LOOP 3							
12	140	268	396	_Fxyy_CHn_DB	DB	Dead zone	PV Unit	0~10000	0	Read/write

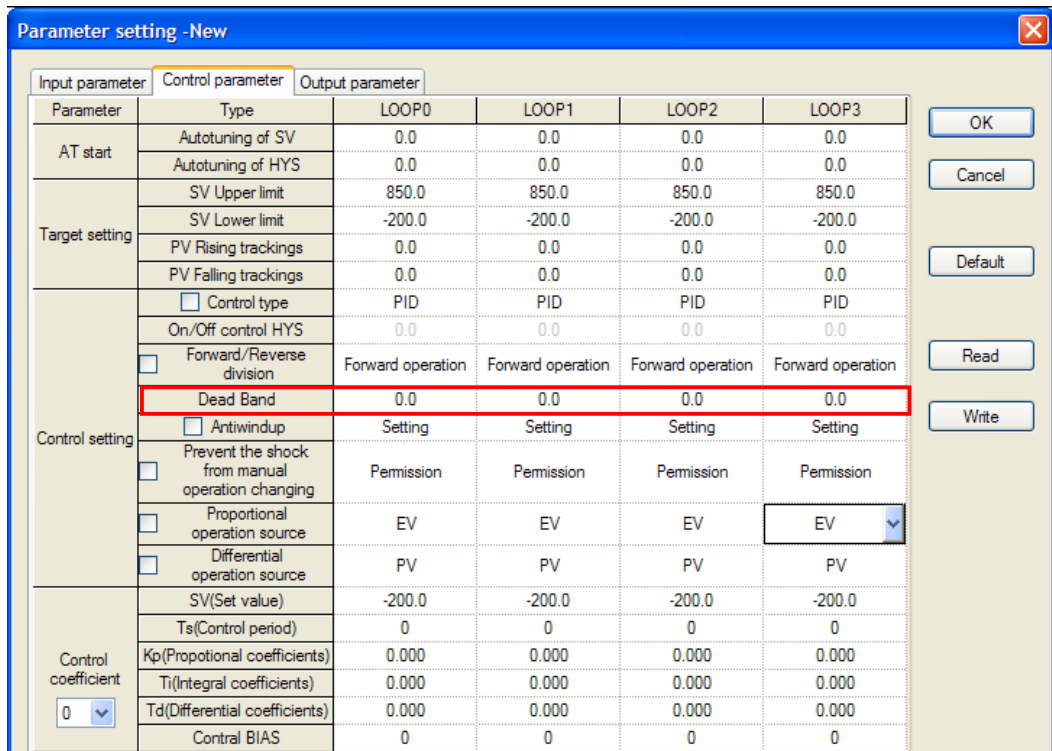

Dead zone operates according to the value configured to the parameter. That means if 0 is configured, it does not move. With SV as the center, set dead zone as much as the configured value up and down. Therefore, if PV is between (SV-configuration value) ~ (SV+configuration value), the control error (EV) is processed as 0. This function makes the operator stable, but there is a delay to detect change in the system.

(3) Anti wind-up

Address (Decimal number)				Symbol name for XGI/XGR	Symbol	Description	Unit	Range	Initial value	Attribute
LOOP 0	LOOP 1	LOOP 2	LOOP 3							
10.1	138.1	266.1	385.1	_Fxyy_CHn_CTRL	CTRL.AW2D	Prevention of overload	code	0:configuration 1 : prohibited	0	Read/write

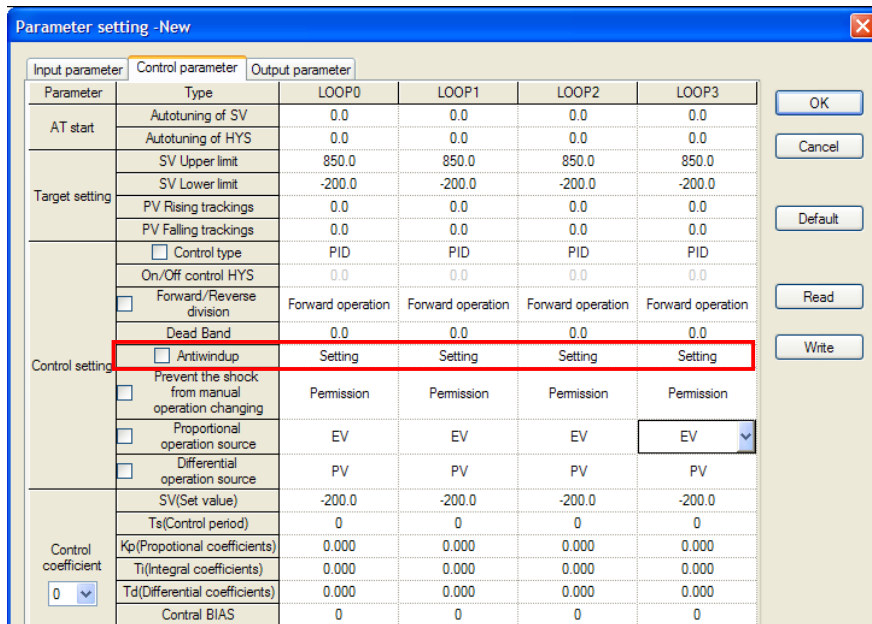

When changing SV or starting initial system, EV becomes bigger to make the system overloaded. This function divides the area of the system to prevent overloaded. Since this function may not be normally operated when P calculation source is PV, in this case it is recommended to be prohibited.

(4) Prevent the shock from manual operation changing

Address (Decimal number)				Symbol name for XGI/XGR	Symbol	Description	Unit	Range	Initial value	Attribute
LOOP 0	LOOP 1	LOOP 2	LOOP 3							
28.0	156.0	284.0	412.0	_Fxyyy_CHn_CTP	CTP.BMPL	Manually avoid impact	code	0 : Allowed 1 :Prohibited	0	Read/write

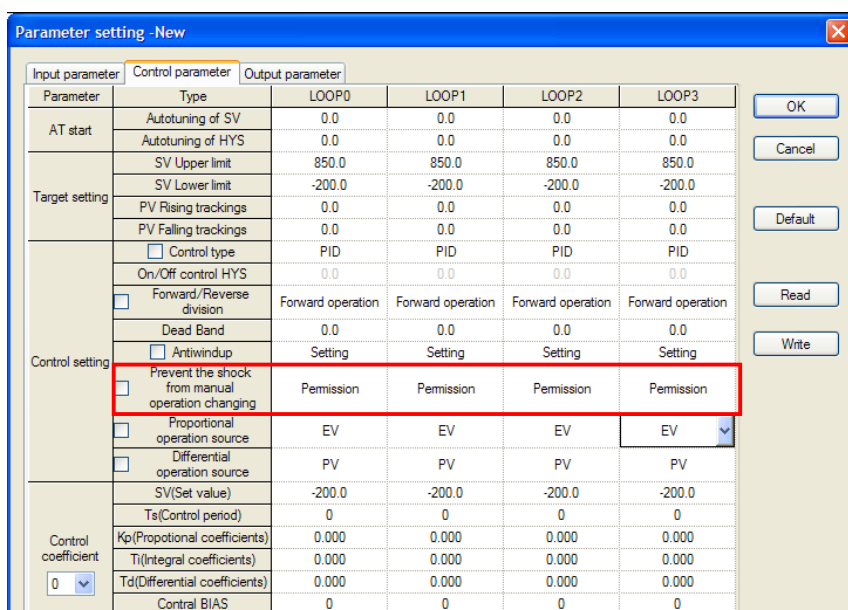

In controlling system, it may be changed to manual mode from automatic mode or to automatic mode from manual mode by order of user. This function finds smooth starting point when the system is converted to automatic mode from manual mode.

When it becomes automatic mode, the output in the manual mode is divided, and replace it with the output prior to P calculation and I calculation to continue the control process smoothly. However, if the difference between two modes is big, it may not be overcome by this function.

(5) Select proportional calculation source

Address (Decimal number)				Symbol name for XGI/XGR	Symbol	Description	Unit	Range	Initial value	Attribute
LOOP 0	LOOP 1	LOOP 2	LOOP 3							
28.1	156.1	284.1	412.1	_Fxyy_CHn_CTP	CTP.P_PV	Select proportional calculation source	code	0 : EV 1 : PV	0	Read/write

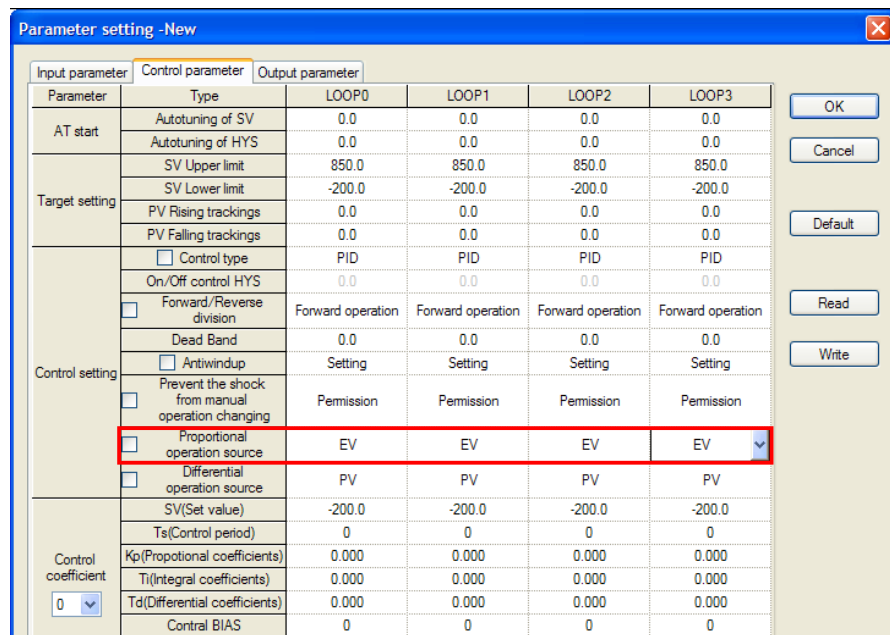

This is the function to determine which one to be used by conducting proportional calculation. Generally, EV is used, but PV is slow and if you want to follow SV, then you can change the source to PV. If PV is used as source, the integral term will be decreased to maintain balance according to the system status. Therefore there will be significant delay factors and make the responsiveness bad due to external factors.

(6) Select differential calculation source

Address (Decimal number)				Symbol name for XGI/XGR	Symbol	Description	Unit	Range	Initial value	Attribute
LOOP 0	LOOP 1	LOOP 2	LOOP 3							
28.2	156.2	284.2	412.2	_Fxyy_CHn_CTP	CTP.D_EV	Select differential calculation source	code	0 : PV 1 : EV	0	Read/write

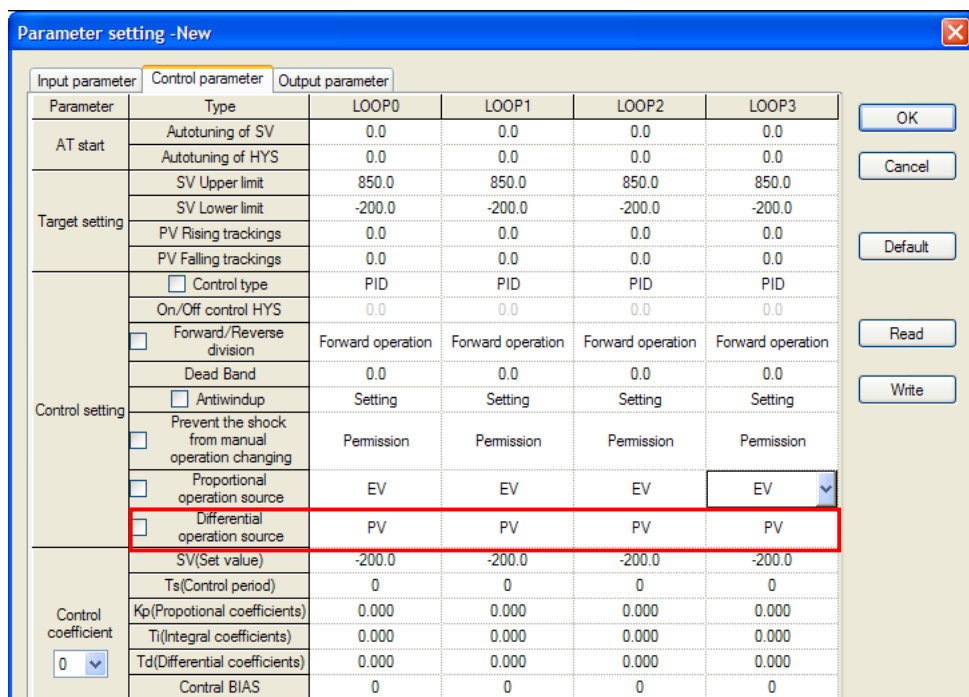

The feature of differential calculation is to measure the change volume of EV. If SV is constant, the change volume of EV will be in reverse way of the change volume and signal of PV, but the size is same. However, when a user changes SV, EV rapidly changes and does not affect PV significantly. Therefore, in order to prevent rapid increase and decrease of operation output according to the changes of SV, PV is used as a source of differential calculation. However, the signal is different according to the direction of change of EV and PV respectively.

(7) Select control set

Address (Decimal number)				Symbol name for XGI/XGR	Symbol	Description	Unit	Range	Initial value	Attribute
LOOP 0	LOOP 1	LOOP 2	LOOP 3							
Ubs.26	Ubs.27	Ubs.28	Ubs.29	_xxyy_CHn_CSET	ref_Cno	Select control set	None	0 ~ 5	0	Read/write

Note) Ubs.26~Ubs.29 refers to the address of U device area.

Parameter setting -New

Parameter	Type	LOOP0	LOOP1	LOOP2	LOOP3
AT start	Autotuning of SV	0.0	0.0	0.0	0.0
	Autotuning of HYS	0.0	0.0	0.0	0.0
Target setting	SV Upper limit	850.0	850.0	850.0	850.0
	SV Lower limit	-200.0	-200.0	-200.0	-200.0
	PV Rising trackings	0.0	0.0	0.0	0.0
	PV Falling trackings	0.0	0.0	0.0	0.0
Control setting	<input type="checkbox"/> Control type	PID	PID	PID	PID
	<input type="checkbox"/> On/Off control HYS	0.0	0.0	0.0	0.0
	<input type="checkbox"/> Forward/Reverse division	Forward operation	Forward operation	Forward operation	Forward operation
	Dead Band	0.0	0.0	0.0	0.0
	<input type="checkbox"/> Antiwindup	Setting	Setting	Setting	Setting
	<input type="checkbox"/> Prevent the shock from manual operation changing	Permission	Permission	Permission	Permission
	<input type="checkbox"/> Proportional operation source	EV	EV	EV	EV
	<input type="checkbox"/> Differential operation source	PV	PV	PV	PV
	SV(Set value)	-200.0	-200.0	-200.0	-200.0
	Ts(Control period)	0	0	0	0
Control coefficient	Kp(Propotional coefficients)	0.000	0.000	0.000	0.000
	Ti(Integral coefficients)	0.000	0.000	0.000	0.000
	Td(Differential coefficients)	0.000	0.000	0.000	0.000
	Control BIAS	0	0	0	0

Buttons: OK, Cancel, Default, Read, Write

Total 6 parameters including SV, Ts, Kp, Ti, Td, control BIAS which are most frequently changed during PID calculation and tuning work can be combined as one control set. This set can be made up to 6. Each set's description can be configured from the parameter settings window, and the configured set can be performed at stop or while operating from the module status window if applied to operation. It can be used when repetitive and circulative change is necessary and when several patterns are necessary for SV change or system condition change

Module	LOOP 0	LOOP 1	LOOP 2	LOOP 3
Loop	LOOP 0	LOOP 1	LOOP 2	LOOP 3
Run	Stop	Stop	Stop	Stop
Auto/Man	Auto	Auto	Auto	Auto
SV no.	0	0	0	0
AT start	Start	Start	Start	Start
AT Status	Ready	Ready	Ready	Ready
Ext. Input	Prohibit	Prohibit	Prohibit	Prohibit

6.2.5 Auto tuning

Address (Decimal number)				Symbol name for XGI/XGR	Symbol	Description	Unit	Range	Initial value	Attribute
LOOP 0	LOOP 1	LOOP 2	LOOP 3							
Ubs.18.2	Ubs.19.2	Ubs.20.2	Ubs.21.2	_xyyy_CHn_ATEN	ref_COMM .ATEN	Start auto tuning	code	0 : Stop 1 : Start	0	Read/write
0.1	128.1	256.1	284.1	_Fxyyy_CHn_STAT	STAT.AT	Status of auto tuning	code	0 : Stop 1 : Tuning	0	Read
0.2	128.2	256.2	284.2	_Fxyyy_CHn_STAT	STAT.ATFAIL	Notify auto tuning failed	code	0 : Normal 1 : Failed	0	Read
6	134	262	390	_Fxyyy_CHn_AT_STEP	AT_STEP	auto tuning stage	code	0 ; Prepared ~ 8 : Finished	0	Read
29	157	285	413	_Fxyyy_CHn_AT_SV	AT_SV	auto tuning goal	PV Unit	SVlower limit~SVupper limit	0	Read/write
30	158	286	414	_Fxyyy_CHn_AT_HYS	AT_HYS	auto tuning hysteresis	PV Unit	0~10000	0	Read/write

Note) Ubs.18.2~Ubs.21.2 refers to the bit address of U device area.

Parameter setting -New

Parameter	Type	LOOP0	LOOP1	LOOP2	LOOP3
AT start	Autotuning of SV	0.0	0.0	0.0	0.0
	Autotuning of HYS	0.0	0.0	0.0	0.0
Target setting	SV Upper limit	850.0	850.0	850.0	850.0
	SV Lower limit	-200.0	-200.0	-200.0	-200.0
	PV Rising trackings	0.0	0.0	0.0	0.0
Control setting	PV Falling trackings	0.0	0.0	0.0	0.0
	<input type="checkbox"/> Control type	PID	PID	PID	PID
	On/Off control HYS	0.0	0.0	0.0	0.0
	<input type="checkbox"/> Forward/Reverse division	Forward operation	Forward operation	Forward operation	Forward operation
	Dead Band	0.0	0.0	0.0	0.0
	<input type="checkbox"/> Antiwindup	Setting	Setting	Setting	Setting
	<input type="checkbox"/> Prevent the shock from manual operation changing	Permission	Permission	Permission	Permission
	<input type="checkbox"/> Proportional operation source	EV	EV	EV	EV
	<input type="checkbox"/> Differential operation source	PV	PV	PV	PV
	SV(Set value)	-200.0	-200.0	-200.0	-200.0
Control coefficient	Ts(Control period)	0	0	0	0
	Kp(Proportional coefficients)	0.000	0.000	0.000	0.000
	Ti(Integral coefficients)	0.000	0.000	0.000	0.000
	Td(Differential coefficients)	0.000	0.000	0.000	0.000
Control BIAS	0	0	0	0	

Buttons: OK, Cancel, Default, Read, Write

Module	LOOP 0	LOOP 1	LOOP 2	LOOP 3
Loop				
Run	Stop	Stop	Stop	Stop
Auto/Man	Auto	Auto	Auto	Auto
SV no.	0	0	0	0
AT start	Start	Start	Start	Start
AT Status	Ready	Ready	Ready	Ready
Ext. Input	Prohibit	Prohibit	Prohibit	Prohibit

Auto tuning is the function to observe the response of the system and find right PID coefficient and calculation cycle through pulse trial in the situation where PID CONTROL system is established. In order to do auto tuning, first of all, configure AT_SV. This value is only used for auto tuning. During auto tuning, this value cannot be changed. When terminating auto tuning, the AT_SV value is not used. Next, configure AT_HYS. At this time, configure it to the lowest value but more than noise of the sensor. If AT_HYS value is too low, it causes auto tuning failed, and too high, it hinders accurate auto tuning. Lastly, configure MV_max and MV_min value. These values are determined by output parameter settings. With the Forward action as the criteria, MV_max follows the maximum limited configuration of HOUT, and MV_min is used by attaching minus sign to the maximum value of cooling output. That means if users mix the configured output parameter with the MV_max as the largest heating condition, and MV_min as the largest cooling condition. Afterwards, make order to start auto tuning and check out whether there is skipping step (excluding step 7) while looking into the increase of auto tuning step. Step1, 3, 5 is a zone where the controller reaches to AT_SV+AT_HYS with maximum output, and Step 2, 4, 6 is a zone where the controller reaches to AT_SV-AT_HYS with minimum output. Since Step7 is a moment (about 0.2 sec.) when calculating control coefficient as a result of Step 1-6, it may not be observed. Step8 means the zone of auto tuning completed and normal operation zone. Therefore, if there is any step not observed during Step 1-6, it is mostly caused since AT_HYS configuration is too low and the system responses to this noise. Therefore, increase the AT_HYS value and retry it. The Figure below shows the graph of auto tuning status. If the linear characteristics of sensor and operator are maintained, conduct auto tuning at AT_SV, and operate it as SV to prevent overshooting. If auto tuning is completed, newly generated parameters are Ts, Kp, Ti, Td, and these values are written over the module automatically at the timing of output. At this time, since previous parameters are deleted, save them before auto tuning.

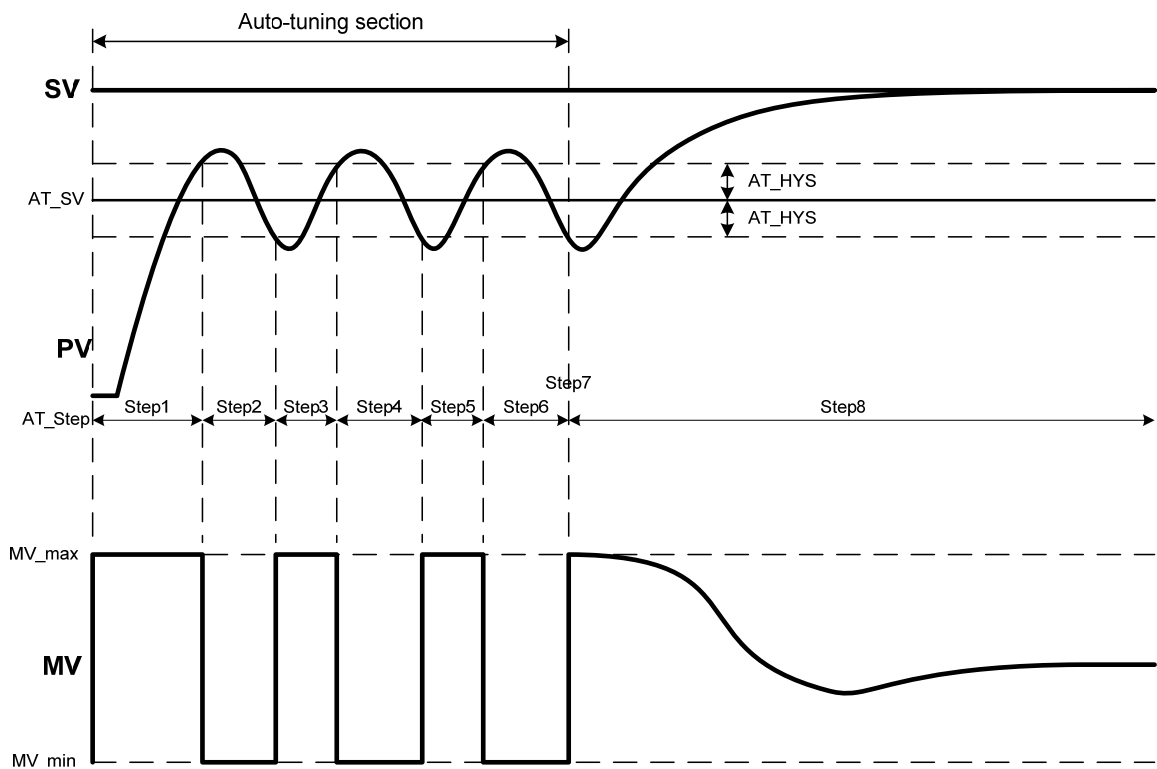

6.3 Output Parameter

6.3.1 Output settings

(1) Select heating/cooling

Output can be configured as follows

Even loop: prohibited, heating, cooling, heating/cooling

Odd loop: prohibited, heating, cooling.

When configuring even loop as heating/cooling, the odd loops (input, control, output parameter) are inactivated. When configuring heating/cooling for even loop, cooling output description for even loop is displayed through the output terminal of the odd loop.

Address (Decimal number)				Symbol name for XGI/XGR	Symbol	Description	Unit	Range	Initial value	Attribute
LOOP 0	LOOP 1	LOOP 2	LOOP 3							
10.2	138.2	266.2	394.2	_Fxyy_CHn_CTRL	CTRL.HSEL	Select heating/cooling	None	0 : Prohibited 1 : Heating 2 : Cooling 3 : Heating/ Cooling	1	Read/write

Parameter	Type	LOOP0	LOOP1	LOOP2	LOOP3
Output setting	Heating/cooling selection	Heating	Heating	Heating	Heating
	Cooling power ratio	Prohibit	100	100	100
Heating output	Output type	Heating	PWM Output	PWM Output	PWM Output
	PWM period	Heating/Cooling	5.0	5.0	5.0
	Output upper limit	100.00	100.00	100.00	100.00
	Output lower limit	0.00	0.00	0.00	0.00
	Output change limit	100.00	100.00	100.00	100.00
	Output standards	0.00	0.00	0.00	0.00
	Manual output value	0.00	0.00	0.00	0.00
	Abnormal condition output	<input type="checkbox"/>	Minimum	Minimum	Minimum
Cooling output	Output type	PWM Output	PWM Output	PWM Output	PWM Output
	PWM period	5.0	5.0	5.0	5.0
	Output upper limit	100.00	100.00	100.00	100.00
	Output lower limit	0.00	0.00	0.00	0.00
	Output change limit	100.00	100.00	100.00	100.00
	Output standards	0.00	0.00	0.00	0.00
	Manual output value	0.00	0.00	0.00	0.00
	Abnormal condition output	<input type="checkbox"/>	Minimum	Minimum	Minimum
Output alarm	Heating upper limit	100.00	100.00	100.00	100.00
	Heating lower limit	0.00	0.00	0.00	0.00
	Cooling upper limit	100.00	100.00	100.00	100.00
	Cooling lower limit	0.00	0.00	0.00	0.00
	Alam HYS	0.00	0.00	0.00	0.00

(2) Cooling output ratio

Configure the cooling generation ratio against the heating output.

Address (Decimal number)				Symbol name for XGI/XGR	Symbol	Description	Unit	Range	Initial value	Attribute
LOOP 0	LOOP 1	LOOP 2	LOOP 3							
36	164	292	420	_Fxyy_CHn_HC_RATE	HC_RATE	Cooling output ratio settings	%	0~100	0	Read/write

6.3.2 Heating output

(1) Output type

There is a PWM output.

Address (Decimal number)				Symbol name for XGI/XGR	Symbol	Description	Unit	Range	Initial value	Attribute
LOOP 0	LOOP 1	LOOP 2	LOOP 3							
10.6	138.6	266.6	394.6	_Fxyy_CHn_CTRL	CTRL.HTY	Select output type	None	PWM output	0	Read/write

Parameter	Type	LOOP0	LOOP1	LOOP2	LOOP3
Heating/cooling selection	<input type="checkbox"/>	Heating	Heating	Heating	Heating
Cooling power ratio		100	100	100	100
Output type		PWM Output	PWM Output	PWM Output	PWM Output
PWM period		5.0	5.0	5.0	5.0
Output upper limit		100.00	100.00	100.00	100.00
Output lower limit		0.00	0.00	0.00	0.00
Output change limit		100.00	100.00	100.00	100.00
Output standards		0.00	0.00	0.00	0.00
Manual output value		0.00	0.00	0.00	0.00
Abnormal condition output	<input type="checkbox"/>	Minimum	Minimum	Minimum	Minimum
Output type		PWM Output	PWM Output	PWM Output	PWM Output
PWM period		5.0	5.0	5.0	5.0
Output upper limit		100.00	100.00	100.00	100.00
Output lower limit		0.00	0.00	0.00	0.00
Output change limit		100.00	100.00	100.00	100.00
Output standards		0.00	0.00	0.00	0.00
Manual output value		0.00	0.00	0.00	0.00
Abnormal condition output	<input type="checkbox"/>	Minimum	Minimum	Minimum	Minimum
Heating upper limit		100.00	100.00	100.00	100.00
Heating lower limit		0.00	0.00	0.00	0.00
Cooling upper limit		100.00	100.00	100.00	100.00
Cooling lower limit		0.00	0.00	0.00	0.00
Alam HYS		0.00	0.00	0.00	0.00

(2) PWM cycle settings

Configure the pulse output cycle to be used for PWM output.

The range of settings is 5(0.5sec)~1200(120.0sec).

Address (Decimal number)				Symbol name for XGI/XGR	Symbol	Description	Unit	Range	Initial value	Attribute
LOOP 0	LOOP 1	LOOP 2	LOOP 3							
37	165	293	421	_Fxyy_CHn_H_PTIME	H_PTIME	PWM cycle	sec	5~1200 (0.5~120.0[sec])	5.0	Read/write

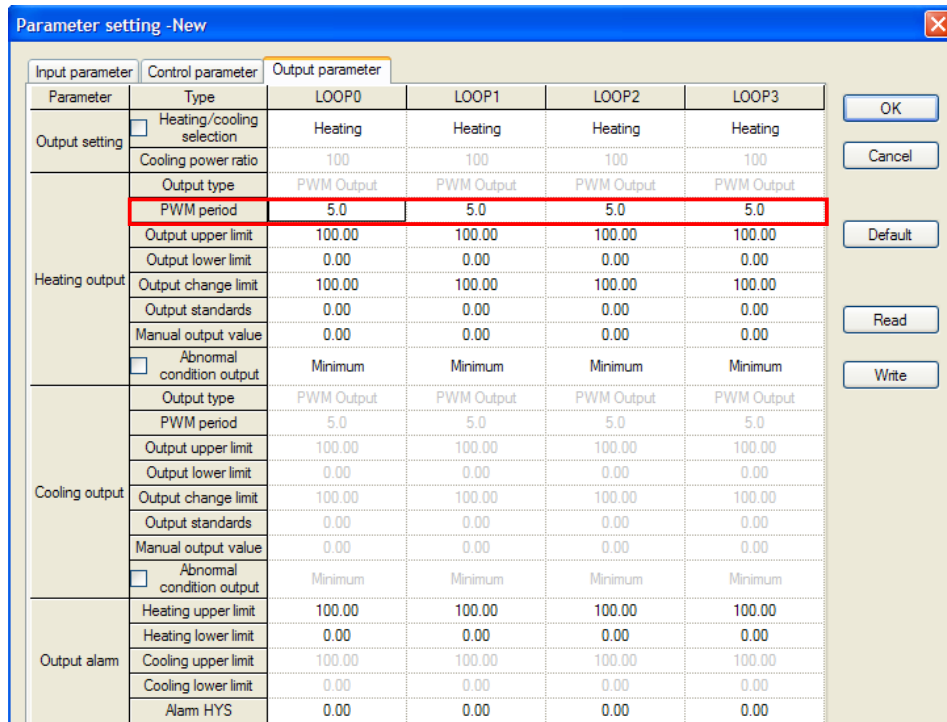

(3) Upper/lower limit of output

The upper/lower limit configuration is the function to limit the upper/lower limit of output against the value entered by a user.

When setting upper/lower limit of output, the value entered by a user is larger than the value set by upper limit of output, then the output value will be the upper limit value of output, and the value entered by a user is smaller than the value set by the lower limit of output, then the output value will be the lower limit value of output.

(a) Upper limit of output

The range available for settings is '0.00~100.00'

Actual settings range is 'output lower limit~100.00'.

Address (Decimal number)				Symbol name for XGI/XGR	Symbol	Description	Unit	Range	Initial value	Attribute
LOOP 0	LOOP 1	LOOP 2	LOOP 3							
38	166	294	422	_Fxyy_CHn_H_MAX	H_MAX	output upper limit	%	0.00~100.00	100.00	Read/write

(b) Output lower limit

The range available for settings is '0.00~100.00'.

Actual settings range is '0.00~output upper limit'.

Address (Decimal number)				Symbol name for XGI/XGR	Symbol	Description	Unit	Range	Initial value	Attribute
LOOP 0	LOOP 1	LOOP 2	LOOP 3							
39	167	295	423	_Fxyy_CHn_H_MIN	H_MIX	output lower limit	%	0.00~100.00	0.00	Read/write

(4) Limitation of changes in output

This is the function to limit the change volume of output to protect operation part by blocking rapid change of output.

Address (Decimal number)				Symbol name for XGI/XGR	Symbol	Description	Unit	Range	Initial value	Attribute
LOOP 0	LOOP 1	LOOP 2	LOOP 3							
40	168	296	424	_Fxyy_CHn_H_DMAX	H_DMAX	Output change limited	%	0.00~100.00	100.00	Read/write

(a) Limit output change: The range available for settings is '0.00~100.00'.

(b) Parameter settings method is as follows.

- 1) Set the selection of heating/cooling as heating in the output settings from output parameter window
- 2) Enter the setting value in the limitation change of heating output.

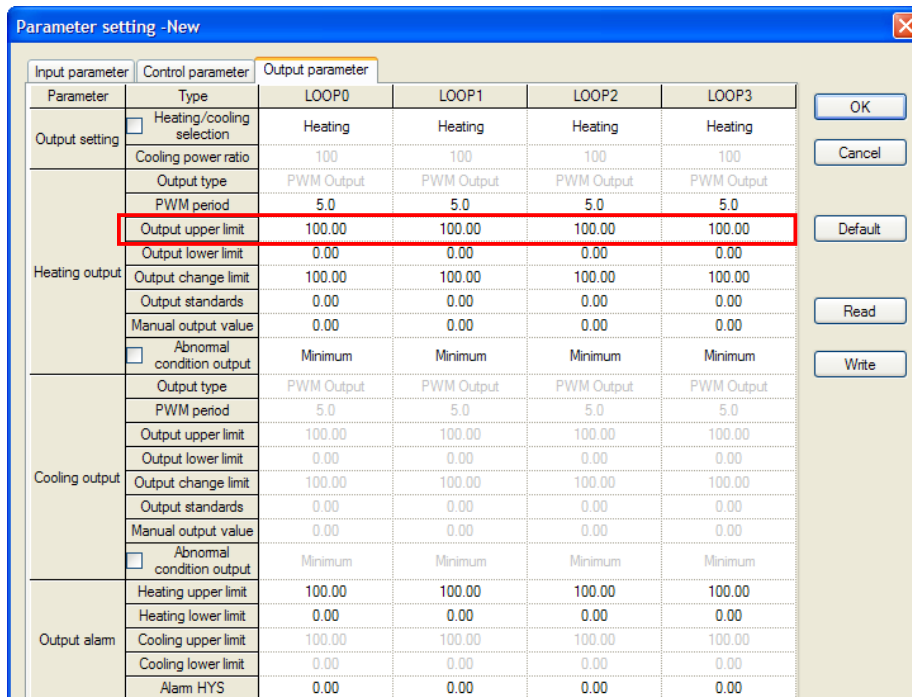

(c) When setting limitation of output change, the output value is as follows.

Analogue output value: 0 → 100

Limit output change: 10

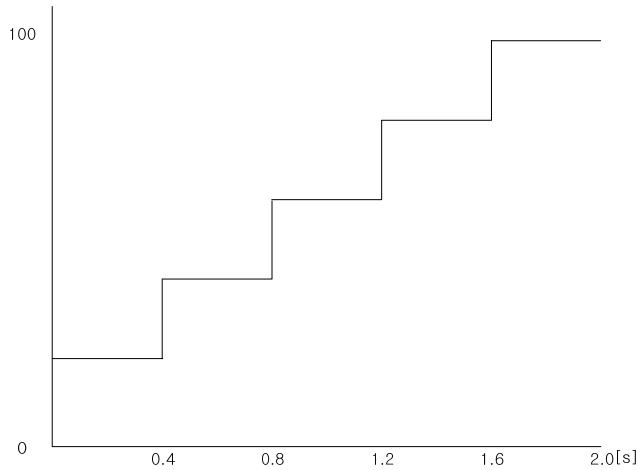

(5) Output criteria

Set the criteria of output which will be out even without output.

Set the output which can stabilize the system even without control.

Address (Decimal number)				Symbol name for XGI/XGR	Symbol	Description	Unit	Range	Initial value	Attribute
LOOP 0	LOOP 1	LOOP 2	LOOP 3							
41	169	297	425	_Fxyy_CHn_H_REF	H_REF	Output criteria	%	-50.00~50.00	0	Read/write

(6) Manual output value

The output value will be the manual output value entered by a user.

In order to output with the manual output value, the 'automatic/manual' shall be set as manual in the module status window.

Address (Decimal number)				Symbol name for XGI/XGR	Symbol	Description	Unit	Range	Initial value	Attribute
LOOP 0	LOOP 1	LOOP 2	LOOP 3							
43	171	299	427	_Fxyy_CHn_H_MAN	H_MAN	Manual output value	%	0.00~100.00	0	Read/write

(a) Manual output value range: The range to be configured is '0.00~100.00'.

(b) The parameter settings method is as follows.

- 1) Configure the heating/cooling to 'heating' in the output parameter window.
- 2) Enter the settings value into the manual output value of heating output.

Parameter setting - New

Input parameter	Control parameter	Output parameter			
Parameter	Type	LOOP0	LOOP1	LOOP2	LOOP3
Output setting	<input type="checkbox"/> Heating/cooling selection	Heating	Heating	Heating	Heating
	Cooling power ratio	100	100	100	100
Heating output	Output type	PWM Output	PWM Output	PWM Output	PWM Output
	PWM period	5.0	5.0	5.0	5.0
	Output upper limit	100.00	100.00	100.00	100.00
	Output lower limit	0.00	0.00	0.00	0.00
	Output change limit	100.00	100.00	100.00	100.00
	Output standards	0.00	0.00	0.00	0.00
	Manual output value	0.00	0.00	0.00	0.00
<input type="checkbox"/> Abnormal condition output	Minimum	Minimum	Minimum	Minimum	
Cooling output	Output type	PWM Output	PWM Output	PWM Output	PWM Output
	PWM period	5.0	5.0	5.0	5.0
	Output upper limit	100.00	100.00	100.00	100.00
	Output lower limit	0.00	0.00	0.00	0.00
	Output change limit	100.00	100.00	100.00	100.00
	Output standards	0.00	0.00	0.00	0.00
	Manual output value	0.00	0.00	0.00	0.00
<input type="checkbox"/> Abnormal condition output	Minimum	Minimum	Minimum	Minimum	
Output alarm	Heating upper limit	100.00	100.00	100.00	100.00
	Heating lower limit	0.00	0.00	0.00	0.00
	Cooling upper limit	100.00	100.00	100.00	100.00
	Cooling lower limit	0.00	0.00	0.00	0.00
	Alarm HYS	0.00	0.00	0.00	0.00

Buttons: OK, Cancel, Default, Read, Write

3) Configure 'automatic/manual' to manual in the module status window.

Module	LOOP 0	LOOP 1	LOOP 2	LOOP 3
Loop	LOOP 0	LOOP 1	LOOP 2	LOOP 3
Run	Stop	Stop	Stop	Stop
Auto/Man	Auto	Auto	Auto	Auto
SV no.	0	0	0	0
AT start	Start	Start	Start	Start
AT Status	Ready	Ready	Ready	Ready
Ext. Input	Prohibit	Prohibit	Prohibit	Prohibit

(7) Abnormal status output

Designate the value of output when the temperature controller module has an error.
The abnormal output settings can be configured as 'minimum/medium/maximum.'

Address (Decimal number)				Symbol name for XGI/XGR	Symbol	Description	Unit	Range	Initial value	Attribute
LOOP 0	LOOP 1	LOOP 2	LOOP 3							
42	170	298	426	_Fxyy_CHn_H_EOUT	H_EOUT	Abnormal output value	None	1 : minimum 2 : medium 3 : maximum	1	Read/write

Parameter setting -New

Input parameter	Control parameter	Output parameter			
Parameter	Type	LOOP0	LOOP1	LOOP2	LOOP3
Output setting	<input type="checkbox"/> Heating/cooling selection	Heating	Heating	Heating	Heating
	Cooling power ratio	100	100	100	100
Heating output	Output type	PWM Output	PWM Output	PWM Output	PWM Output
	PWM period	5.0	5.0	5.0	5.0
	Output upper limit	100.00	100.00	100.00	100.00
	Output lower limit	0.00	0.00	0.00	0.00
	Output change limit	100.00	100.00	100.00	100.00
	Output standards	0.00	0.00	0.00	0.00
	Manual output value	0.00	0.00	0.00	0.00
<input type="checkbox"/> Abnormal condition output	Minimum	Minimum	Minimum	Minimum	
Cooling output	Output type	PWM Output	PWM Output	PWM Output	PWM Output
	PWM period	5.0	5.0	5.0	5.0
	Output upper limit	100.00	100.00	100.00	100.00
	Output lower limit	0.00	0.00	0.00	0.00
	Output change limit	100.00	100.00	100.00	100.00
	Output standards	0.00	0.00	0.00	0.00
	Manual output value	0.00	0.00	0.00	0.00
<input type="checkbox"/> Abnormal condition output	Minimum	Minimum	Minimum	Minimum	
Output alarm	Heating upper limit	100.00	100.00	100.00	100.00
	Heating lower limit	0.00	0.00	0.00	0.00
	Cooling upper limit	100.00	100.00	100.00	100.00
	Cooling lower limit	0.00	0.00	0.00	0.00
	Alarm HYS	0.00	0.00	0.00	0.00

Buttons: OK, Cancel, Default, Read, Write

6.3.3 Cooling output

(1) Output type

There is a PWM output.

Address (Decimal number)				Symbol name for XGI/XGR	Symbol	Description	Unit	Range	Initial value	Attribute
LOOP 0	LOOP 1	LOOP 2	LOOP 3							
10.7	138.7	266.7	394.7	_Fxyy_CHn_CTRL	CTRL.CTY	Select output type	None	1 : PWM output	1	Read/write

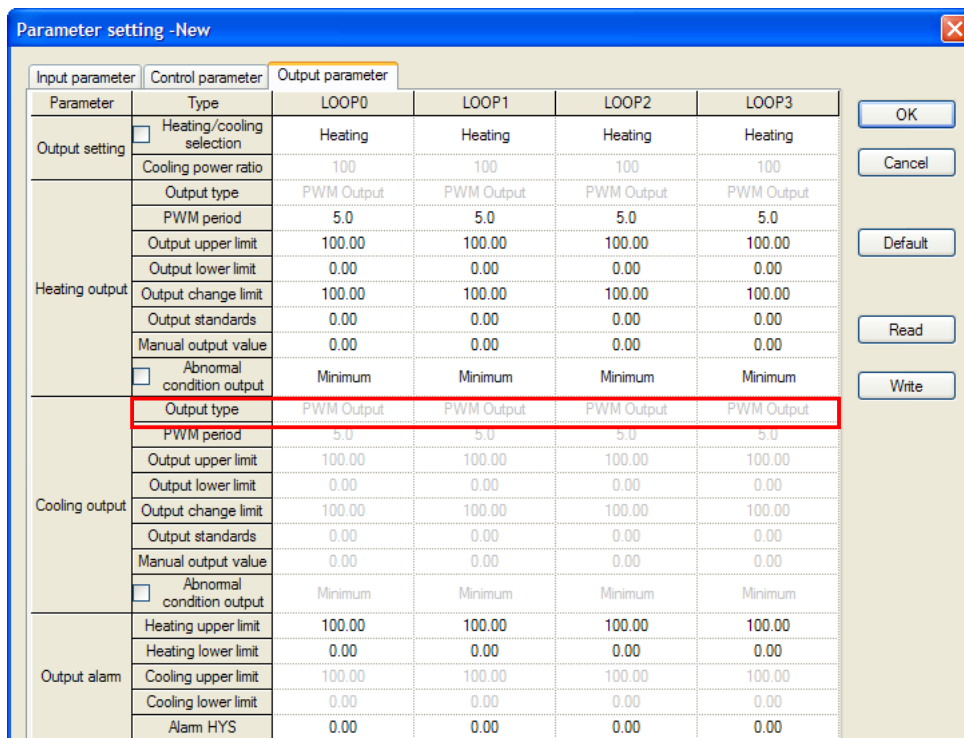

(2) PWM cycle settings

This configures the pulse output cycle to be used for PWM output.

The range to be configured is 5(0.5sec)~1200(120.0sec).

Address (Decimal number)				Symbol name for XGI/XGR	Symbol	Description	Unit	Range	Initial value	Attribute
LOOP 0	LOOP 1	LOOP 2	LOOP 3							
48	176	304	432	_Fxyy_CHn_C_PTIME	C_PTIME	PWM cycle	sec	5~1200 (0.5~120.0 [sec])	5.0	Read/write

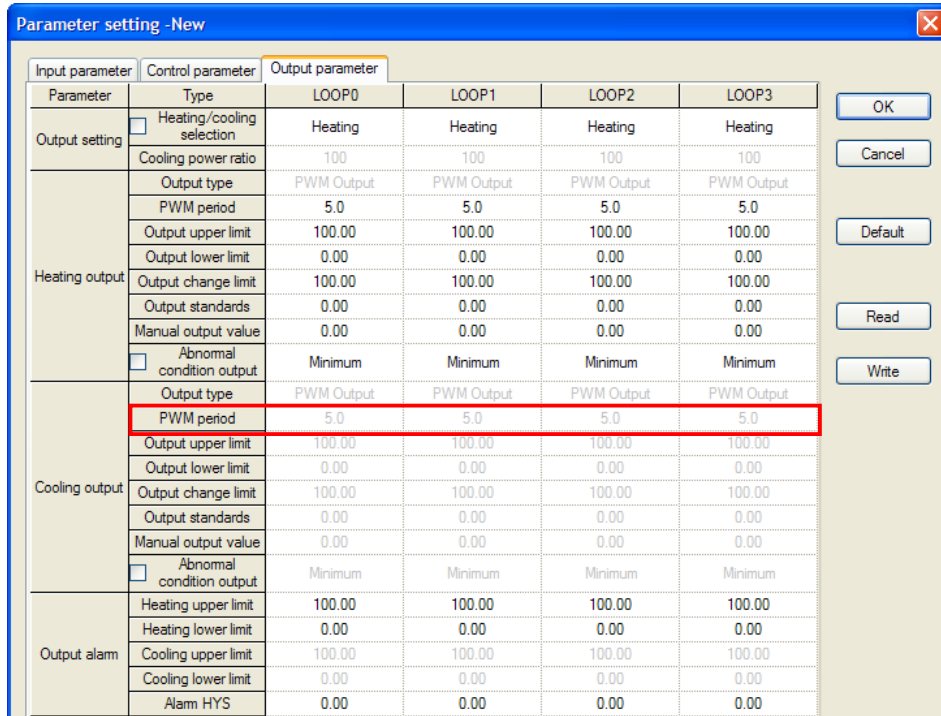

(3) Upper/lower limit of output

The upper/lower limit configuration is the function to limit the upper/lower limit of output against the value entered by a user.

When setting upper/lower limit of output, the value entered by a user is larger than the value set by upper limit of output, then the output value will be the upper limit value of output, and the value entered by a user is smaller than the value set by the lower limit of output, then the output value will be the lower limit value of output.

- (a) Output upper limit : Range available for settings is '0.00~100.00' .
Actual settings range is 'output lower limit~100.00'.

Address (Decimal number)				Symbol name for XGI/XGR	Symbol	Description	Unit	Range	Initial value	Attribute
LOOP 0	LOOP 1	LOOP 2	LOOP 3							
49	177	305	433	_Fxyy_CHn_C_MAX	C_MAX	output upper limit	%	0.00~100.00	100.00	Read/write

- (b) Output lower limit: Range available for settings is '0.00~100.00' .
Actual settings range is '0.00~output upper limit'.

Address (Decimal number)				Symbol name for XGI/XGR	Symbol	Description	Unit	Range	Initial value	Attribute
LOOP 0	LOOP 1	LOOP 2	LOOP 3							
50	178	306	434	_Fxyy_CHn_C_MIN	C_MIN	output lower limit	%	0.00~100.00	0.00	Read/write

(4) Output change limited

This is the function to limit the output change volume to protect the operation part by blocking rapid change.

Address (Decimal number)				Symbol name for XGI/XGR	Symbol	Description	Unit	Range	Initial value	Attribute
LOOP 0	LOOP 1	LOOP 2	LOOP 3							
51	179	307	435	_Fxyy_CHn_C_DMAX	C_DMAX	Limit output change	%	0.00~100.00	100.00	Read/write

(a) Limit output change: The range available for configuration is '0.00~100.00'.

(b) The parameter settings method is as follows.

(c) When configuring output change limit, the output value is as follows.

Analogue output value: 100 → 0

Limit output change: 20

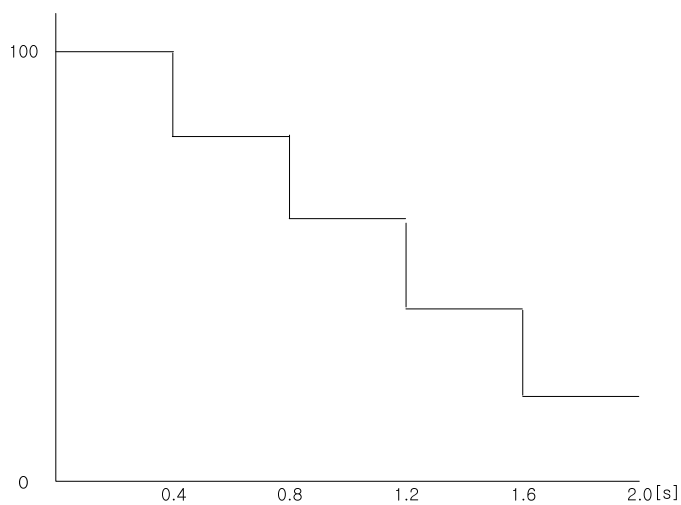

(5) Output criteria

This configures the criteria of output which will be out even without effort to do it.

It configures the output which stabilizes the system even without control.

Address (Decimal number)				Symbol name for XGI/XGR	Symbol	Description	Unit	Range	Initial value	Attribute
LOOP 0	LOOP 1	LOOP 2	LOOP 3							
52	180	308	436	_Fxyy_CHn_C_REF	C_REF	Output criteria	%	-50.00~50.00	0	Read/write

(6) Manual output value

The output value is out as the manual output value entered by the user.

In order to make manual output value, set manual from 'automatic/manual' from the module status window.

Address (Decimal number)				Symbol name for XGI/XGR	Symbol	Description	Unit	Range	Initial value	Attribute
LOOP 0	LOOP 1	LOOP 2	LOOP 3							
54	182	310	438	_Fxyy_CHn_C_MAN	C_MAN	manual output value	%	0.00~100.00	0	Read/write

(a) manual output value Range: The range available for configuration is '0.00~100.00'.

(7) Abnormal status output

Designate the value of output when the temperature controller module has an error.

The abnormal status output configuration can be configured as 'minimum/medium/maximum.'

Address (Decimal number)				Symbol name for XGI/XGR	Symbol	Description	Unit	Range	Initial value	Attribute
LOOP 0	LOOP 1	LOOP 2	LOOP 3							
53	181	309	437	_Fxyy_CHn_C_EOUT	C_EOUT	Abnormal output value	None	1 : Minimum 2 : Medium 3 : Maximum	1	Read/write

Parameter	Type	LOOP0	LOOP1	LOOP2	LOOP3
Output setting	Heating/cooling selection	Heating	Heating	Heating	Heating
	Cooling power ratio	100	100	100	100
	Output type	PWM Output	PWM Output	PWM Output	PWM Output
	PWM period	5.0	5.0	5.0	5.0
	Output upper limit	100.00	100.00	100.00	100.00
	Output lower limit	0.00	0.00	0.00	0.00
	Output change limit	100.00	100.00	100.00	100.00
	Output standards	0.00	0.00	0.00	0.00
	Manual output value	0.00	0.00	0.00	0.00
	Abnormal condition output	Minimum	Minimum	Minimum	Minimum
	Output type	PWM Output	PWM Output	PWM Output	PWM Output
	PWM period	5.0	5.0	5.0	5.0
	Output upper limit	100.00	100.00	100.00	100.00
	Output lower limit	0.00	0.00	0.00	0.00
	Output change limit	100.00	100.00	100.00	100.00
	Output standards	0.00	0.00	0.00	0.00
	Manual output value	0.00	0.00	0.00	0.00
	Abnormal condition output	Minimum	Minimum	Minimum	Minimum
	Heating upper limit	100.00	100.00	100.00	100.00
	Heating lower limit	0.00	0.00	0.00	0.00
	Cooling upper limit	100.00	100.00	100.00	100.00
	Cooling lower limit	0.00	0.00	0.00	0.00
	Alarm HYS	0.00	0.00	0.00	0.00

6.4 Other Functions

6.4.1 Alarm function

(1) Input alarm

Input alarm configuration has [upper upper limit], [upper limit], [lower limit], [lower lower limit]. When digital output value strays from the value designated by input alarm settings, the alarm flag is turned on. If the digital output value comes in the designated alarm settings value, then the alarm flag is deleted. Also, the alarm flag release condition can be set up by using [alarm HYS]. As shown in the figure below, the case of setting the input alarm is explained.

Input parameter	Control parameter	Output parameter
Parameter	Type	LOOP0
Input type	<input type="checkbox"/> Input type	Pt100: -200 ~ 850
	<input type="checkbox"/> Short circuit	Permission
	Upper limit of effective input	850.0
	Lower limit of effective input	-200.0
	Upper limit of scale	850.0
	Lower limit of scale	-200.0
Input process	Input BIAS	0.0
	<input type="checkbox"/> Average type	Weighted average
	Average value	0
Input alarm	High upper limit	850.0
	Upper limit	850.0
	Lower limit	-200.0
	Low lower limit	-200.0
	Alarm HYS	0.0

(a) In case digital output value is 750.0 °C -> Upper limit flag On

(b) In case digital output value is 745.0 °C -> Upper limit flag On (Maintained)

Since alarm HYS is configured at 10.0 from the example above, the , digital output value should be less than 740.0 °C to turn off the upper limit flag.

(c) In case digital output value is -210.0 °C -> lower limit, lower-lower limit flag On

(d) In case digital output value is -195 °C -> lower limit, lower-lower limit flag On(maintained)

In the case above, since the alarm HYS is set at 10.0, the digital output value has to be more than -190.0 °C to turn off the lower -lower limit flag.

(e) In case digital output value is -150 °C -> lower limit flag On, lower-lower limit flag Off

6.4.2 Output alarm

Output alarm settings are a function to make alarm when it strays from the value configured by the user.

Output alarm settings do not affect the output value.

In order to set up, enter the setting value of the heating upper limit, heating lower limit, cooling upper limit, cooling lower limit into the output alarm of output parameter window.

In order to put hysteresis on the border of the alarm, you should configure the entering point and escaping point separately.

Chapter 7 Software Package (XG-TCON)

7.1 Introduction

7.2.1 Features of XG-TCON

- (1) The software package with the functions for the operation and monitoring of the XGT Series Temperature Controller Module.
- (2) This package provides a function for independent operation of the temperature controller separate from the XG5000.
- (3) Enables fast and easy parameter setting and data monitoring.
- (4) Supports convenient GUI for users to begin temperature control without developing ladder program.
- (5) Each project is provided with 0 ~ 7 bases and 0 ~ 11 slots, for up to 48 module installation and supports edition, monitoring and control simultaneously.
- (6) Diverse messages are provided for easy program edit and testing.

7.2.2 Functions of XG-TCON

In principle, the XG-TCON runs in PC environment. It is an exclusive software package developed for fast and easy operation of temperature controller through communication with the XGK, XGI or XGR series CPU.

Major functions of the XG-TCON are as follows.

- (1) Read/write module parameters
- (2) Edit/save module parameters
- (3) Monitor control data
- (4) Plot control data
- (5) Monitor module status
- (6) Display module operation history

7.2.3 Files Created with XG-TCON

Following files are created in the course of creation and edit of a project by user.

- (1) <filename>.tpj: the project file created by user when saving the project.
- (2) <filename>.tpm: the module file created by user when saving the module.
- (3) <filename>.tpl: the file for the loop created by user when saving the loop.
- (4) <filename>.csv: user-created project is periodically saved. This file is created by selecting [Begin Data Save] in the trend graph.

7.2 Main Screen

This Chapter describes the elements, windows, and popup menus in the main screen. The figure below shows the initial screen of the XG-TCON at opening.

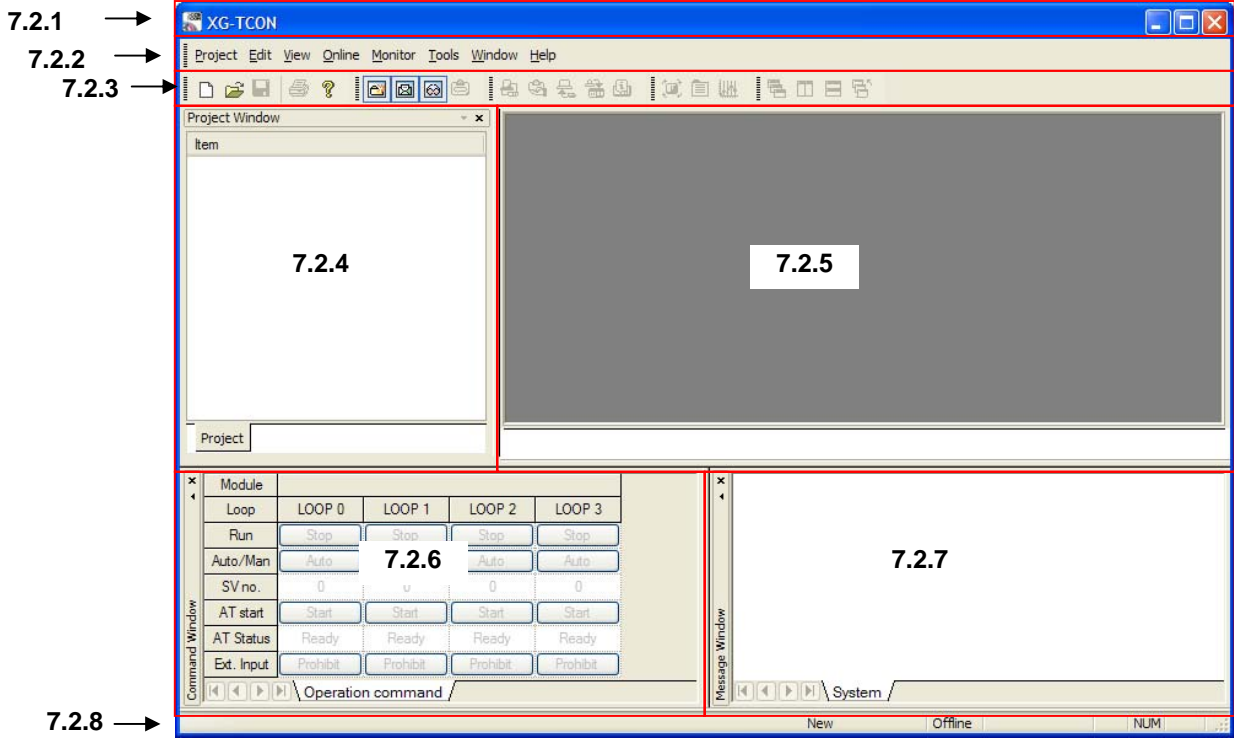

The zones are defined as follows, and described in detail in the respective sectors.

7.2.1 Title

Shows the title and name of the active module of the XG-TCON. XG-TCON's title is displayed as follows according to the Windows application;

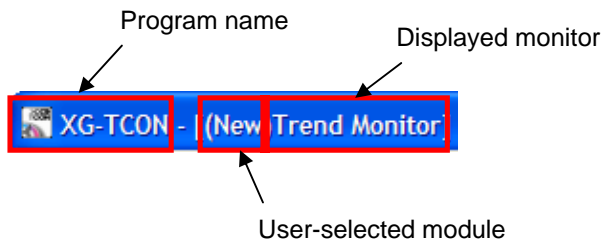

7.2.2 Menu

Basic menus are provided for convenient program operation.

Selecting the menu, following commands will appear. The commands can be executed with mouse or keyboard. Some commands support short-cut key or tool for simple selection.

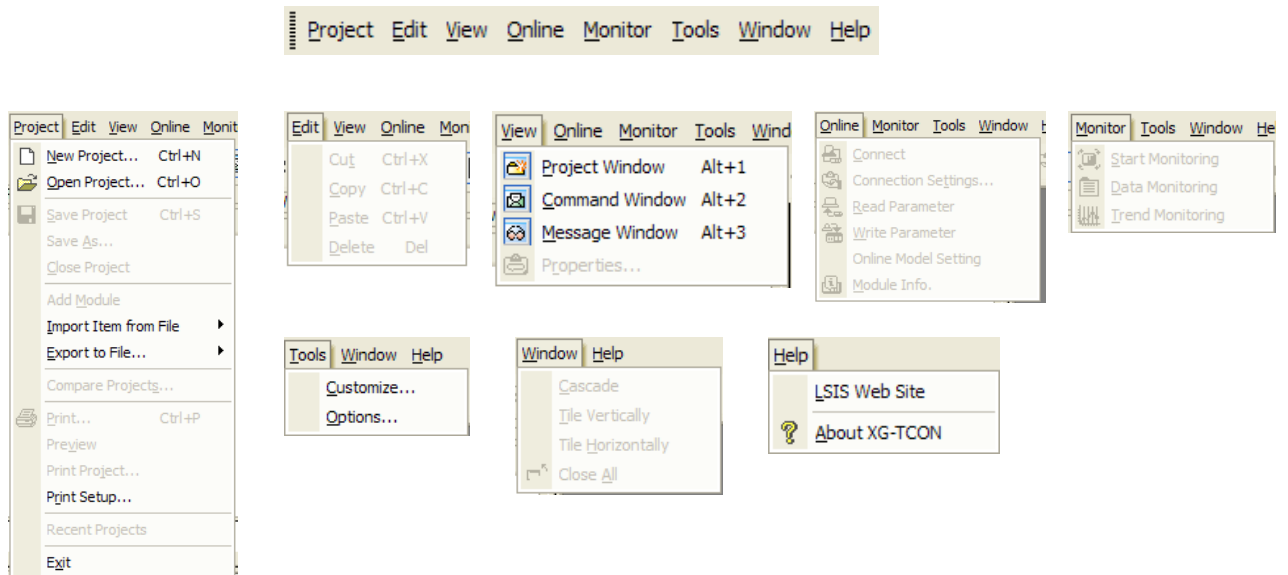

(1) Project

The Project menu supports the functions for creating project and printing.

(a) New Project (tool bar)

Opens [New Project] dialog.

(b) Open Project (tool bar)

Opens [Open] dialog. Past projects saved in memory device can be retrieved.

(c) Save Project (tool bar)

Saves present project. If not project is open, or after saving, this menu is disabled.

(d) Save As

Opens [Save As] dialog. The present project is maintained and a copy is saved under different project name.

(e) Close Project

Closes present project. This menu is disabled if no project is open. If the present project has not been saved, the dialog [XG-TCON: project window will be closed. Will you save the project?] will appear.

(f) Add Module

Opens [Add Module] dialog. Create a new module in the project. If currently in connection, this menu is disabled.

(g) Read Item from File

Placing cursor on this menu will activate 5 selections of Module / Loop 0 / Loop 1 / Loop 2 / Loop 3, and all these 5 items open respective [Open] dialog. File extensions are tpm / tpl / tpl / tpl / tpl, respectively. If a project is selected, this menu is disabled. It will be enabled only when module and parameter are selected.

(h) Save Item in File (tool bar)

[Save As] dialog will open. Disabled if no project is open, and the current project window will save the selected modules and parameters under different name. When saving modules, all the modules and parameters are saved in a .tpm file. When saving a loop, the parameter setting of the loop is saved in a .tpl file.

(i) Compare Projects

Opens [Compare Project] dialog. Compares the present project in the screen and a saved project. Disabled if no project is open.

(j) Print (tool bar)

Opens [Print] dialog supported in the Windows. Data monitor and trend monitor can be printed. Disabled if no monitor is in the main screen.

(k) Print Preview

Opens [Print Preview] window. Print previews for data monitor and trend monitor can be checked before printing. Disabled if no monitor is in the main screen.

(l) Print Project

Opens [Print project] dialog for printing project data. Disabled if not project is open.

(m) Setup Printer

Opens [Setup Printer] dialog. Supports the printer setting dialog of the Windows OS.

(n) Exit

Exits from XG-TCON. If the present project has not been saved, [XG-TCON: project window will be closed. Will you save it?] dialog appears.

(2) Edit

(a) Cut

Cut can be executed when 2 or more modules have been registered. Cut modules can be pasted into other projects.

(b) Copy

The modules registered in the parameter can be copied. All the parameters of the module are copied into other projects or modules.

(c) Paste

Enabled after Copy or Cut command has been executed. Copied or cut module can be pasted. Disabled if Coy or Cut command has not been executed. When trying to paste to a module, following dialog appears for confirmation.

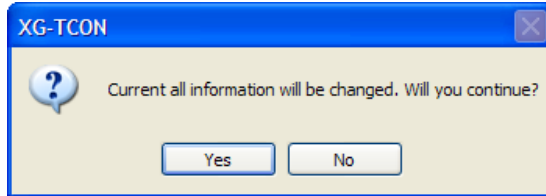

(d) Delete

When 2 or more modules have been set up in the project, and the modules or parameters to be deleted are selected, this menu is enabled. Disabled if the project is selected or there is only one module.

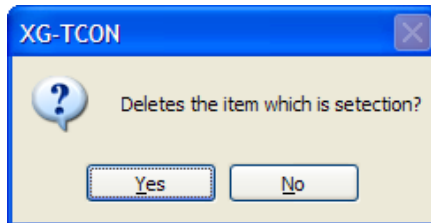

(3) View

(a) Project Window (tool bar)

Enable or Disable of project window can be selected.

Enabled

Disabled

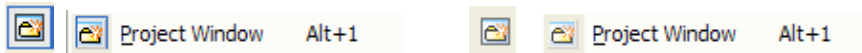

(b) Command Window (tool bar)

Enable or Disable of command window can be selected.

Enabled

Disabled



(c) Message Window (tool bar)

Enable or Disable of message window can be selected.

Enabled

Disabled



(d) Register Information (tool bar)

Opens [Register Information] or [Setting] dialog for the project, module, or parameter selected by the user.

(4) Online

(a) Connect/Disconnect (tool bar)

Connects the XG-TCON and user-defined PLC. When disconnected, 'Connect' is displayed and of connected, 'Disconnect' will appear. If click this while in connection, [Connect] dialog will appear, and if clicked while in disconnect, the connection is isolated.



(b) Connection Setting (tool bar)

Same as the [Connection Setting] dialog of the XG5000.

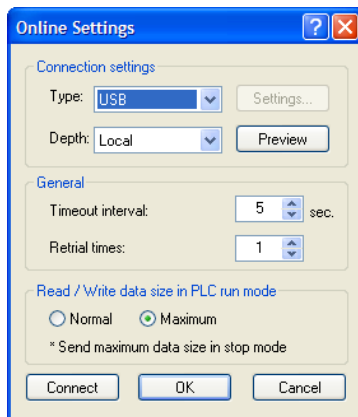

(c) Read (tool bar)

Reads the parameter data stored in the present temperature controller module.

(d) Write (tool bar)

Saves the present parameter data in the temperature controller module.

(e) Online Module Setting (tool bar)

Search the existing (installed) modules and register them in the XG-TCON. All the existing data are deleted, and the data read from the present module is displayed on the parameter window of the newly registered module.

(f) Module Information (tool bar)

Opens [Module Information] dialog.

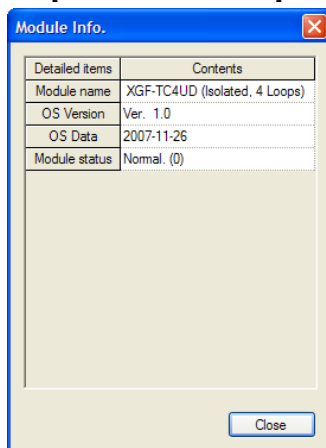

(5) Monitor

(a) Start Monitoring/Stop Monitoring (tool bar)

When not in monitoring, "Start Monitoring" is displayed, and when in monitoring, "Stop Monitoring" is displayed. These two buttons are toggle switches, and if Start Monitoring is clicked, monitoring begins, and vice versa.

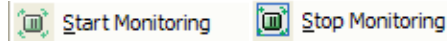

(b) Data Monitoring (tool bar)

Enabled when the XG-TCON is in connection with a PLC. The data monitor window of the focused module appears in the main screen.

(c) Trend Monitoring (tool bar)

Enabled when the XG-TCON is in connection with a PLC. The trend monitor window of the focused module appears in the main screen.

(6) Tools

(a) User Defined

[Use Defined Tool] dialog opens to allow user to define tools or commands.

(b) Options

[Option] dialog opens to allow user to edit XG-TCON environment.

(7) Window

(a) Cascade Arrangement (tool bar)

The active windows in the main screen are arranged in cascade form.

(b) Horizontal Arrangement (tool bar)

The active windows in the main screen are arranged horizontally.

(c) Vertical Arrangement (tool bar)

The active windows in the main screen are arranged vertically.

(d) Close All (tool bar)

All the active monitoring windows in the main screen are closed.

(8) Help

(a) LS Industrial Systems website

Runs Internet browser and access to www.lsis.biz.

(b) About XG-TCON (tool bar)

Opens [XG-TCON Information] dialog.

7.2.3 Tool Bar

Frequently used menus can be selected easily.



Frequently used menus of XG-TCON are provided with short-cut icons in the same shapes as the tool bar in the XG5000.

Icon	Menu	Icon	Menu	Icon	Menu
	New Project		Register Information		Trend Monitoring
	Open Project		Connect/Disconnect		Cascade Arrangement
	Save Project		Set-up Connection		Vertical Arrangement
	Print		Read		Horizontal Arrangement
	XG-TCON Information		Write		Close All
	Project Window		Module Information		
	Module Status Window		Start/stop Monitoring		
	Module Status History Window		Data Monitoring		

7.2.4 Project Window

(1) Popup Menu

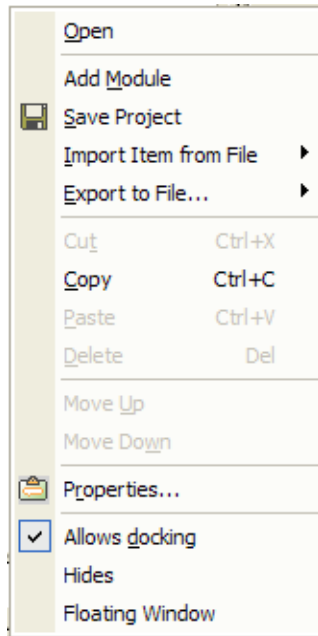

(a) Add Module

Opens [Add Module] dialog in which module name, base and slot setting and description can be edited. Disabled while in connected.

(b) Save Project

Saves project.

(c) Read Items from File

Reads modules (*.tpm) or parameters (*.tpl).

(d) Save Items in File

Saves module (*.tpm) or parameter (*.tpl).

(e) Cut

Cuts off modules.

(f) Copy

Copies modules

(g) Paste

Cut or copied modules can be pasted. When pasting to a project, a module having the existing data is created. However, when pasting to a module, existing parameter information is overwritten.

- (h) Delete
- (i) Move up
Moves the module up at the project window
- (j) Move down
Moves the module down at the project window.
- (k) Register Information
Opens [Project Register Information] dialog in which project name and description can be edited.
- (l) Allow Docking
Usable for window movement or docking with another window. To enable docking, the checkbox must be checked.
- (m) Hide
Hides project window.
- (n) Floating Window
Changes project window into a window. In this state, docking is disabled.

7.2.5 Main Screen

In the main screen, user can display windows for monitoring or plotting data.

The main screen is where user can open data monitoring and trend monitoring windows. Each module can have one data monitoring window and one trend monitoring window. Multiple modules may open multiple data and trend monitoring windows in the main screen. When working with multiple windows, a window can be selected with the tab on the bottom screen. Each tab and title bar has respective module name. When the project is closed, the main screen is empty. The context menu (right mouse button click) in the main screen is as follows.

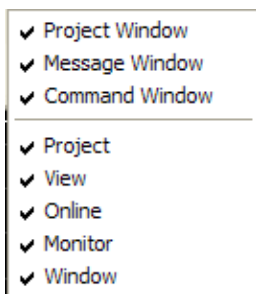

(1) Data Monitoring Window

This window shows major operating information of XG-TCON, and read-only is allowed. When a new project is created, this window has empty columns, and reads and displays module state at Start Monitoring command. The variables in this window are indicated in black or red if the memory value is 0 or non-zero, respectively. Exceptionally, sensor input, heating output, and cooling output variables are indicated in blue when normal or in red when erroneous.

	Type	LOOP 0	LOOP 1	LOOP 2	LOOP 3
Operation information	Sensor input	0.0 °C	0.0 °C	0.0 °C	0.0 °C
	Operation	Stop	Stop	Stop	Stop
	Automatic/Manual operation	Auto	Auto	Auto	Auto
	Control setting	0	0	0	0
	Automatic tuning status	Ready	Ready	Ready	Ready
	Operation error	Normal	Normal	Normal	Normal
	LOW CUT Operation	Prohibit	Prohibit	Prohibit	Prohibit
Alarm condition	Input High upper limit	Normal	Normal	Normal	Normal
	Input upper limit	Normal	Normal	Normal	Normal
	Input lower limit	Normal	Normal	Normal	Normal
	Input Low lower limit	Normal	Normal	Normal	Normal
	Heating upper limit	Normal	Normal	Normal	Normal
	Heating lower limit	Normal	Normal	Normal	Normal
	Cooling upper limit	Normal	Normal	Normal	Normal
Control information	Cooling lower limit	Normal	Normal	Normal	Normal
	Control type	PID	PID	PID	PID
	Forward/Reverse operation	Forward	Forward	Forward	Forward
	PV(Control input)	0.0 °C	0.0 °C	0.0 °C	0.0 °C
	SV(Control target)	0.0 °C	0.0 °C	0.0 °C	0.0 °C
	PV rising tracking	Prohibit	Prohibit	Prohibit	Prohibit
	PV falling tracking	Prohibit	Prohibit	Prohibit	Prohibit
	EV(Control error value)	0.000000	0.000000	0.000000	0.000000
	Dead Band	Prohibit	Prohibit	Prohibit	Prohibit
	Prevention of nover-integral operation	Setting	Setting	Setting	Setting
Output information	MV(Control output)	0.00	0.00	0.00	0.00
	Heating output type	Analog	Analog	Analog	Analog
	Heating output	0.00%	0.00%	0.00%	0.00%
	Cooling output type	Analog	Analog	Analog	Analog
	Cooling output	0.00%	0.00%	0.00%	0.00%

(a) Data Monitor Popup Window

The context menu which appears in the Data Monitoring window by clicking mouse right button is shown below. Active menus are checked and disabled menus are unchecked. Enable/Disable is toggled by selecting. At first appearance, 4 loops, operation information, alarm status, control information, and output information are all checked.

Operating information

Alarm Status

Control Information

Output Information

- LOOP 0
- LOOP 1
- LOOP 2
- LOOP 3
- Operating Information ▶
- Alarm Status ▶
- Control Information ▶
- Output Information ▶

- Sensor Input
- Operation Mode(Run/Stop)
- Control Mode(Automatic/Manual)
- Selected Control Parameter
- Autotuning Status
- Error
- Low Cut

- Process Value Higher Limit Alarm
- Process Value High Limit Alarm
- Process Value Low Limit Alarm
- Process Value Lower Limit Alarm
- Heating Out High Limit Alarm
- Heating Out Low Limit Alarm
- Cooling Out High Limit Alarm
- Cooling Out Low Limit Alarm

- Control Type(PID/CASCADE/ONOFF)
- Control Action(direct/reverse)
- PV(Process Value)
- SV(Set Value)
- PV Up Tracking
- PV Down Tracking
- EV(Error Value)
- Deadband
- Antwindup
- MV(Manipulated Value)

- Heating Out Type
- Heating Out
- Cooling Out Type
- Cooling Out

(2) Trend Monitoring Window

Trend monitoring window shows a part of TC4UD operation data in graphic display. The PV(IN), SV, HOUT and COUT of each loop can be easily registered.

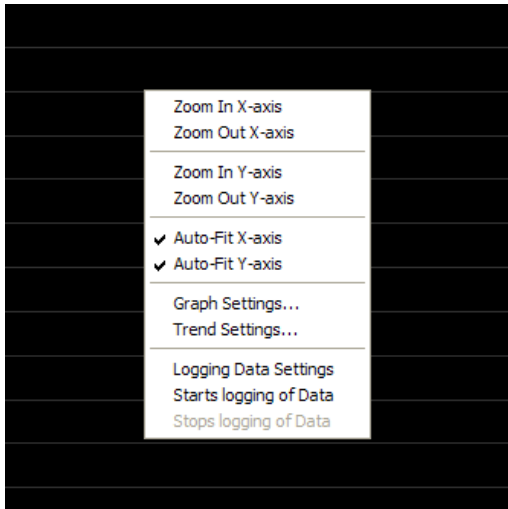

The context menu items in the Trend Monitoring window are as follows.

- (a) Zoom in X-axis
X-axis is zoomed in. Disabled at the maximum magnification.
- (b) Zoom out X-axis
X-axis is zoomed out. Disabled at the minimum magnification.
- (c) Zoom in Y-axis
Y-axis is zoomed in. Disabled at the maximum magnification.
- (d) Zoom out Y-axis
Y-axis is zoomed out. Disabled at the minimum magnification.
- (e) Auto Fit X-axis
Zoom in to the maximum magnification of the X value to be displayed in the screen.
- (f) Auto Fit Y-axis
Zoom in to the maximum magnification of the Y value to be displayed in the screen.
- (g) Graph Setting
Opens [Graph Setting] dialog.
- (h) Trend Setting
Opens [Trend Setting] dialog.
- (i) Logging Data Settings
Opens [Data Save Setting] dialog.
- (j) Starts Logging of data
Begins saving data. "Being saved..." message is displayed at top trend screen during the saving. This menu is disabled during saving operation.
- (k) Stop Logging of data
Stops data saving operation. Enabled during data saving operation only.

Note Logging data

Data is stored in *.csv file supported by Excel program. The data storage format is as shown below.

	A	B	C	D
1	msec	0_PV	1_SV	0_HOUT
2	0	500	1000	1000
3	200	300	1000	2000
4	400	200	1000	100

7.2.6 Command Window

This window monitors Loop operation and support existing settings.

①	Module	New (XGF-TC4UD, Base0, Slot1)			
②	Loop	LOOP 0	LOOP 1	LOOP 2	LOOP 3
③	Run	Stop	Stop	Stop	Stop
④	Auto/Man	Auto	Auto	Auto	Auto
⑤	SV no.	0	0	0	0
⑥	AT start	Start	Start	Start	Start
⑦	AT Status	Ready	Ready	Ready	Ready
⑧	Ext. Input	Prohibit	Prohibit	Prohibit	Prohibit

- (1) Module
Shows the information of the module selected by the user.
- (2) Loop
Shows LOOP0 ~ 4.
- (3) Operation
The button to run the operation of the Loop. Toggles Start/Stop by clicking.
- (4) Auto/Manual
Toggle button for automatic and manual outputs. In manual output mode, the value entered in the control parameter by the user is outputted.
- (5) Control Set
Support six control coefficient from 0 to 5.
- (6) Auto Tuning
Starts auto tuning of the Loop. Toggles start/stop by clicking.
- (7) Tuning Condition
Shows present tuning condition. When auto tuning is stopped, zero (preparation) step is displayed. During operation, one of the steps from 1 to 8 is displayed, where the 8th step is displayed with 'Completed.'
- (8) External Input
This button allows external inputs. Toggles Allow or Prohibit by clicking.

7.2.7 Message Window

Various statuses of the XG-TCON are informed with messages.

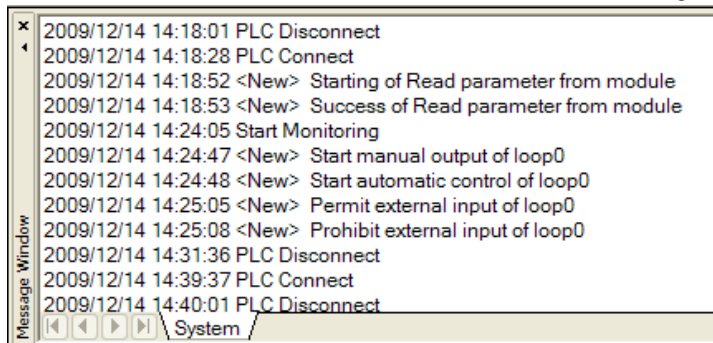

Shows the history of the statuses changes of all the modules registered in the project. Up to 2,000 items can be displayed, classified by module. Context menu is shown below.

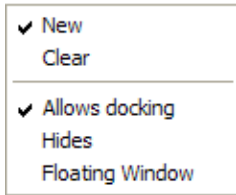

(1) New, New1 (check/uncheck)

New and New1 are the names of the modules registered by the user. Check/uncheck in the check box shows or hides the module name from the history window.

(2) Delete

Disabled if there is not history in the module status history window, or enabled if there in. Deletes all the history from the module status history window.

(3) Allow Docking

Usable for window movement or docking with another window. Enabled if checked, or disabled if unchecked.

(4) Hide

Hides the project window.

(5) Floating Window

Changes the project window to window pane. In this state, Allow Docking menu is disabled.

7.2.8 Status Bar

Shows online status of the module and brief description of menu.

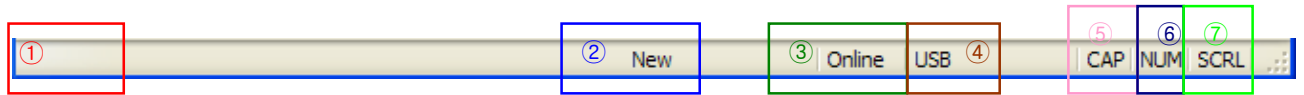

The status bars shows followings.

- (1) Maintains 'Ready' during operation. Shows information on the tool bar on which the cursor is placed.
- (2) Show the name of the module presently selected.
- (3) Shows current communication status. 'Online' when connected with PLC, or 'Offline' when disconnected.
- (4) Shows the current connection method.
- (5) Toggles Caps Lock key.
- (6) Toggles Num Lock key.
- (7) Toggles Scroll Lock key.

7.3. Screen Components

This Chapter describes the dialog boxes which appear by menu selection.

7.3.1 New Project Dialog

This dialog box is for creating new projects with project name as the folder and file names. Created a new folder with the project name and create project file under the name of [Project Name].tpj.

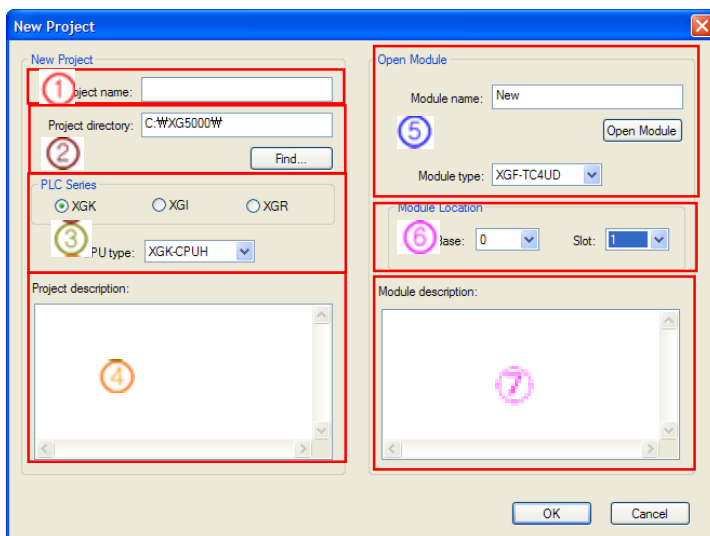

(1) Project Name

Project name can be entered. 100 characters can be entered in the module, except special characters (\/: * ? " < > |).

(2) Project Location

The initial value of project location can be modified in the "Default folder for creating new projects" of [Tools] → [Option], or designated a folder using [Find(F)] menu. Unless for a special purpose, project name will be used as the folder name.

(3) PLC series

You can select PLC series and CPU type.

(4) Project Description

Project description can be entered with up to 30,000 characters. [ENTER] changes lines, and horizontal and vertical scroll bars are provided.

(5) Register Existing Module

[Module Name] enables user to create a module name with up to 100 characters. [Open] enables opening previously stored modules.

(6) Module Location

Module location can be designated using base and slot numbers.

(7) Module Description

Same as the Project Description.

7.3.2 Open Project

This dialog is used for opening the project files, module files, or parameter files previously stored. When the [Open Project] menu is selected from project and tool bar, the project files with .tpj extension only can be opened. If [Read Items from File] is selected, *.tpm or *.tpl files can be opened.

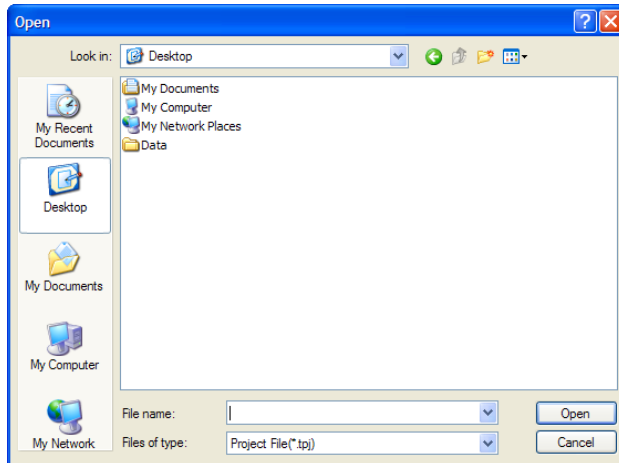

7.3.3 Save As

Save presently open project under different name. New folder can be designated with [Find(F)] menu. Project name and location can be defined with up to 100 characters. Special characters (\ / : * ? " < > |) are not supported.

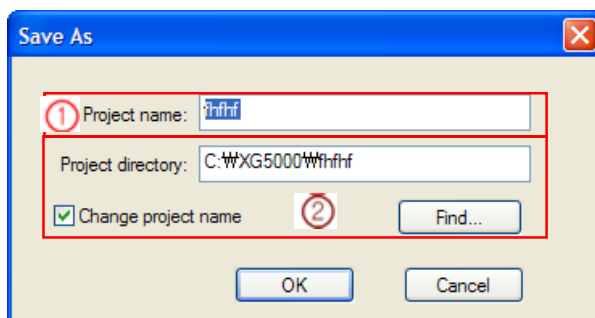

(1) Project Name

Enter the new name of the project to be saved with.

(2) Project Location

Enter the location of the project to be stored under a different name, or select desired folder with [Find(F)]. If the checkbox before the [Change project name too], the name of the project to be stored will be changed too. If unchecked, the present project name is maintained.

7.3.4 Add Module

Modules can be added to [New Project] or [Previously Saved Project].

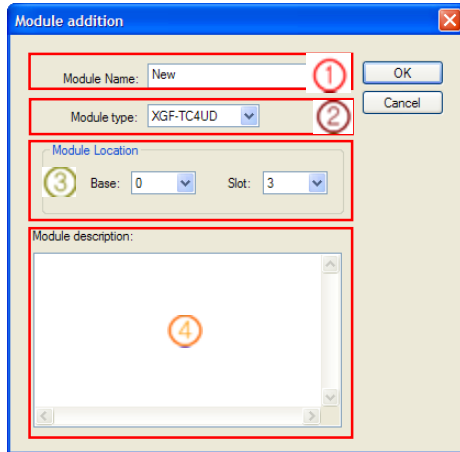

- (1) Module Name
User can name the module with up to 100 characters.
- (2) Module Type
Type of the module to be added is defined.
- (3) Module Location
Module can be located by base and slot numbers.
- (4) Module Description
Module can be described with up to 30,000 characters.
[ENTER] changes text lines.

7.3.5 Compare Projects

Compares the present project with another and shows the result. [Open Project] button calls Open dialog with which user can open another project. When another project is opened, [Compare] button will be activated. Click this button to compare the projects and display the results in the [Module Status History] window.

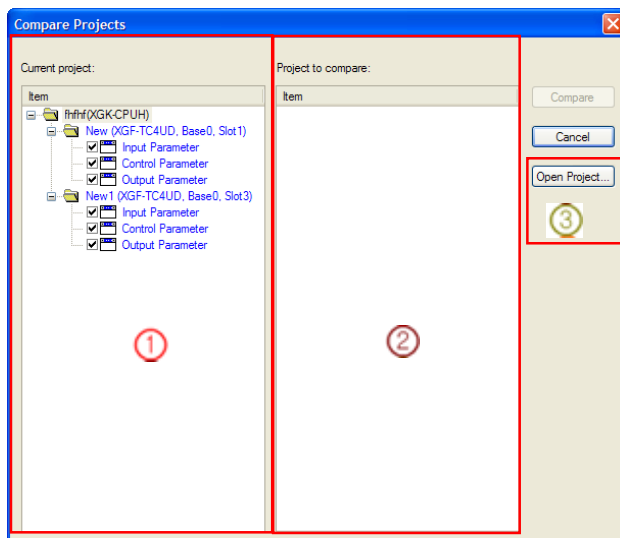

- (1) Current Project
The project presently opened in the XG-TCON.
- (2) Project to be compared
The project opened for comparison.
- (3) Open File
Click this [Open Project] button to open the project for comparison.

7.3.6 Print Preview Window

[Print Preview] changes the XG-TCON screen to print preview screen. This window is in accordance with that of the Windows OS. Select Print to start printing, select [Next Page] to go to the next page, or [Prev Page] to go back to the previous page. [Two Pages] shows 2 pages in the same screen. [Zoom In/Out] shows enlarged or reduced image. [Close] returns to the XG-TCON screen.

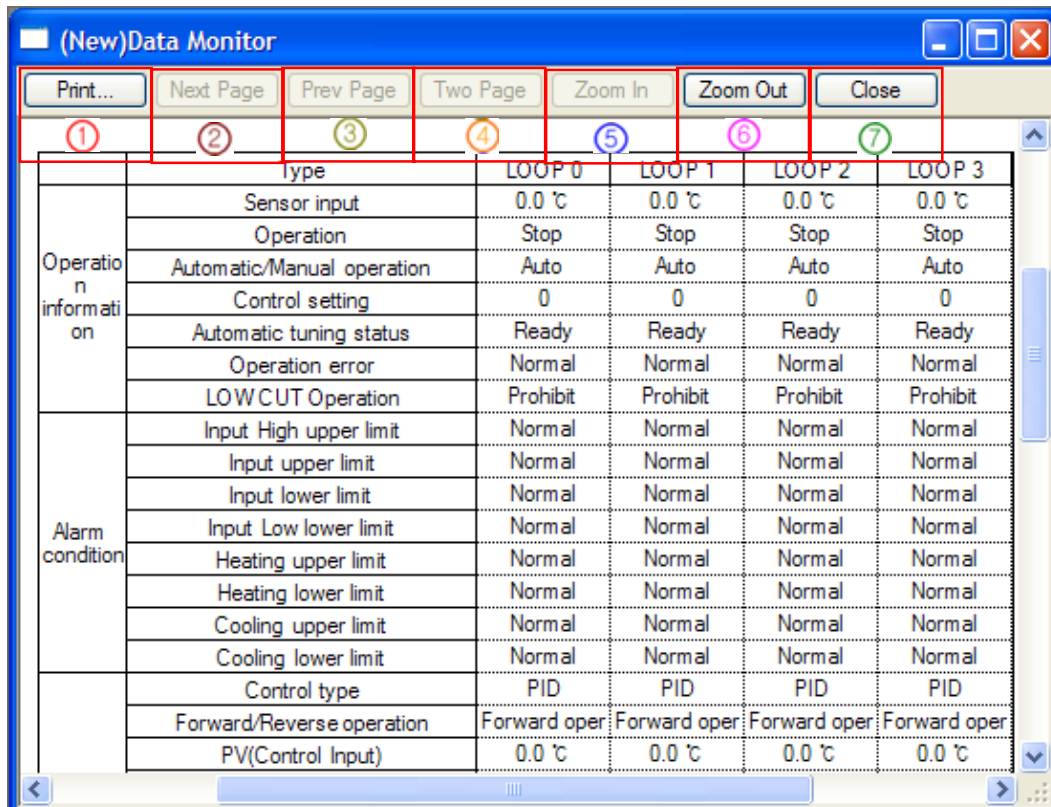

- (1) Print
Shows print dialog.
- (2) Next
Go to the next page.
- (3) Previous
Go to the previous page.
- (4) 2 Pages
Shows 2 pages in the same screen.
- (5) Zoom-in
Zoom in the print preview image.
- (6) Zoom out
Zoom out the print preview image.
- (7) Close
Shows print dialog.

7.3.7 Print Project

This function enables printing the desired items of the project.
 Select (check) the desired items and click Print button to start printing.

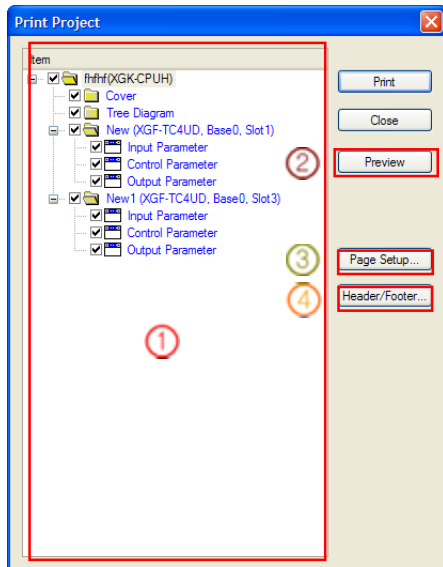

- (1) Items
 Items can be selected for printing by checking the check boxes.
- (2) Print Preview
 Same as the [3.8 Print Preview Window].
- (3) Page Setting
 Print page options can be defined.

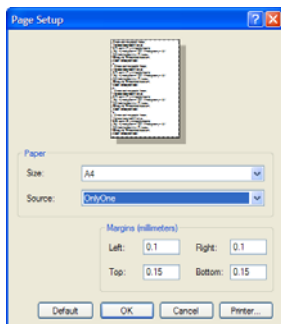

- (4) Header/Footer
 Header and footer options can be defined.

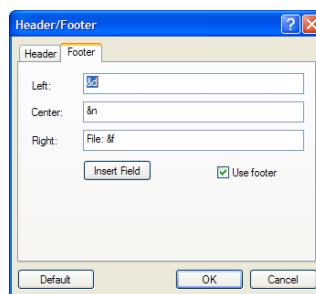
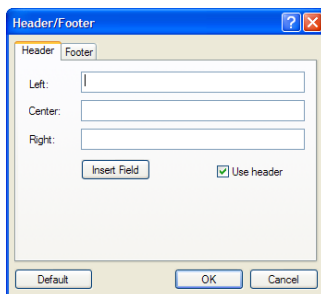

7.3.8 Parameter Register Information

This dialog box is for parameter setting. Input/control/output parameters can be entered by selecting respective tab. Parameter variables are indicated in black for default values. Blue for other than default values, or red for error.

(1) Parameter Common

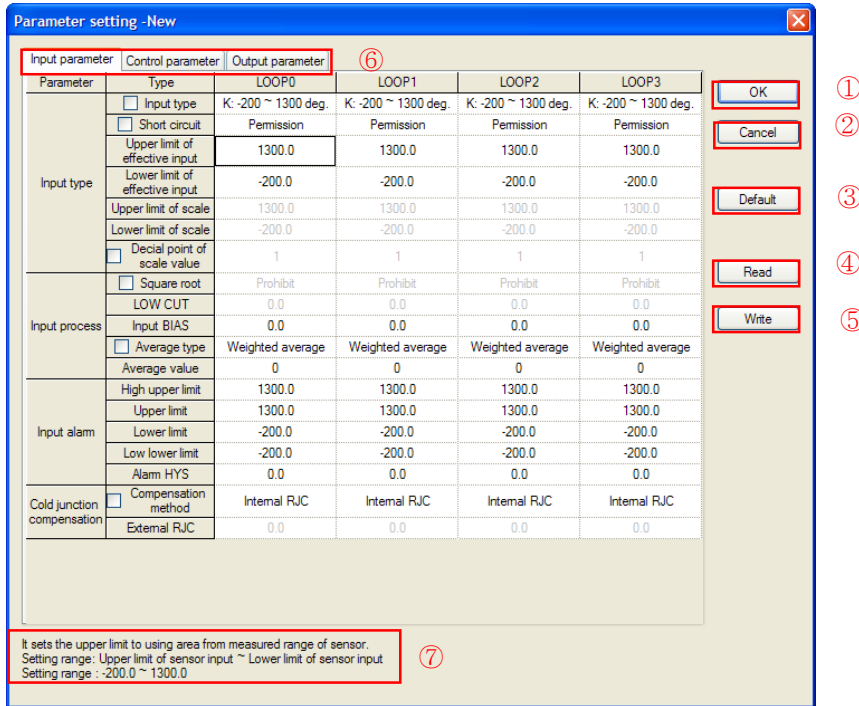

(a) Confirm

Applies the settings in the parameter dialog to the project

(b) Cancel

Cancels all the changes made in the dialog and return to the previous step

(c) Default Setting

Initializes all the settings in the dialog

(d) Read

Reads the parameters of the respective module and display them in the parameter window (supported during connection only)

(e) Write

Transmits the changes made in the parameter window to the module (supported during connection only)

(f) Tab

Select input, output or output parameter tab to open the respective window

- (g) Parameter Description
Describes the variable briefly.

(2) Input Parameters

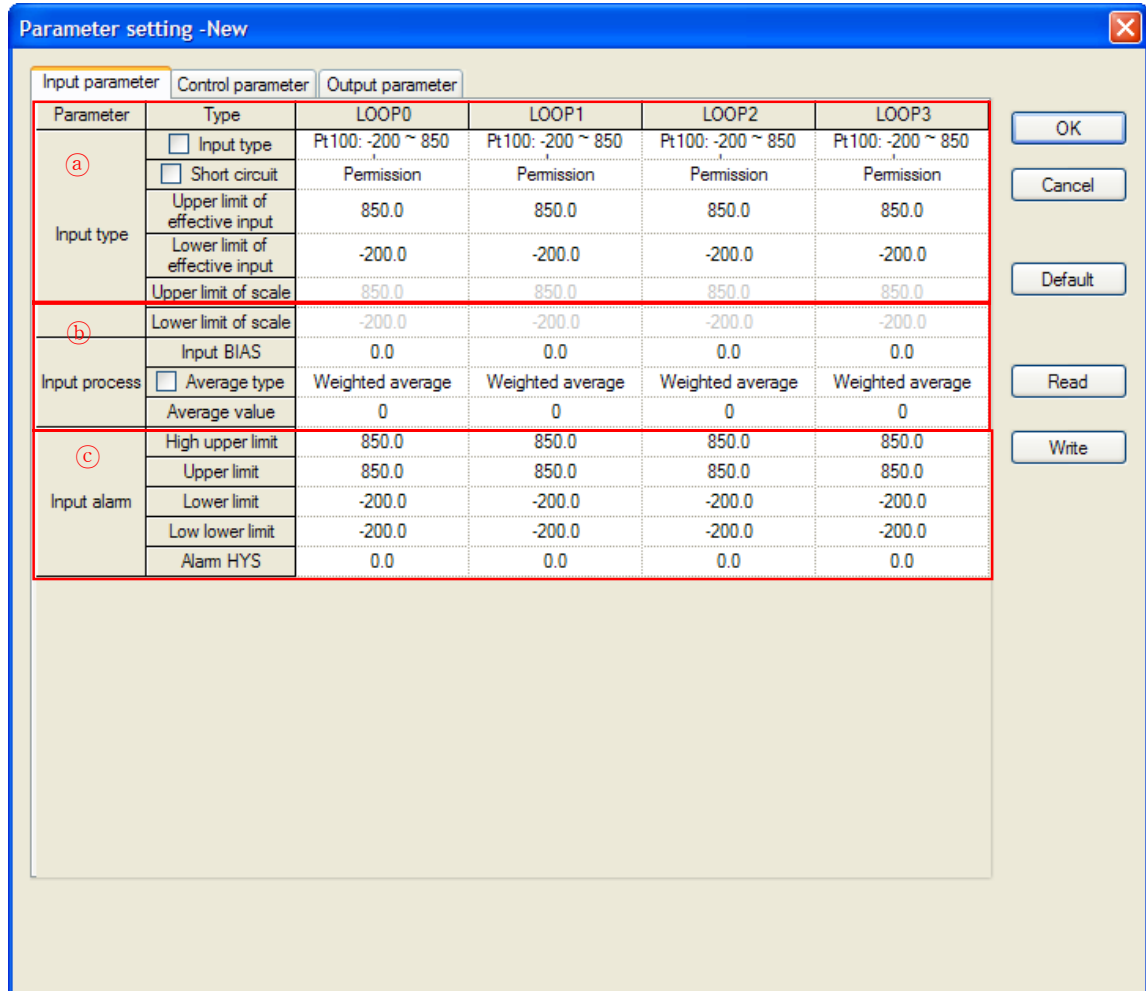

(a) Input Types

1) Input Types

Type	Min.	Max.	Type	Min.	Max.
K, N	-200.0	1300.0	PT100, PT1000	-200.0	850.0
J	-200.0	1200.0	JPT100	-200.0	600.0
T	-200.0	400.0	DC 0 ~ 10mV	0.00	10.00
B	400	1800	DC 0 ~ 100mV	0.0	100.0
S, R	0	1700	DC 0 ~ 1V	0.000	1.000
E	-200.0	1000.0	DC 1 ~ 5V	1.000	5.000
U	-200.0	600.0	DC 0 ~ 5V	0.000	5.000
L	-200.0	900.0	DC 0 ~ 10V	0.00	10.00
C	0	2300	DC -5 ~ 5V	-5.000	5.000
PL2	0.0	1300.0	DC -10 ~ 10V	-10.00	10.00
DC 4 ~ 20mA	4.00	20.00	DC 0 ~ 20mA	0.00	20.00

2) Open Line

If enabled, the sensor is opened physically and treated as an error. If disabled, even real line open will not be treated as open nor error.

3) Effective Input Upper Limit

An INT type, defining the upper limit of the applicable range of the sensor measurement. This limit should be between the maximum to minimum input of the sensor, and higher than the Effective Input Lower Limit.

4) Effective Input Lower Limit

An INT type, defining the lower limit of the applicable range of the sensor measurement. This limit should be between the maximum to minimum input of the sensor, and lower than the Effective Input Upper Limit.

5) Scale Upper Limit

An INT type. For temperature type, same as the effective input upper limit, and set up the upper limit in the voltage and current input scale. Setting range is 'Scale Upper Limit > Lower Limit + 30000' within -30000 ~ 30000.

6) Scale Lower Limit

An INT type. For temperature type, same as the effective input lower limit, and set up the lower limit in the voltage and current input scale. Setting range is 'Scale Lower Limit < Upper Limit - 30000' within -30000 ~ 30000.

7) Scale Decimal Point

Used only for voltage and current, to set up the decimal point of the upper and lower limits of scale, within the range of 0(x1) ~ 4(x0.0001).

(b) Process Input

1) Root Square

Extract the square root of the input. If the input value is a minus, the minus sign will be applied the same.

2) Low Cut

A USINT type, which can be entered only when square root is allowed. After extracting the square root, the value less than the LOW CUT% of the entire input range is treated as zero input. Setting range is 0(0%) ~ 50(5.0%).

3) Input Bias

An INT type, which sets bias to input values. Setting range is less than the entire input range within -30000 ~ 30000.

4) Average Type

Sets up the type of the averaging filter applied to input values. The types include weighted and moving average.

5) Average Value

A USINT type, which sets up the constant for the averaging filter. Setting range is (Weighted Average: 0(0%) ~ 99(99%), Moving Average 0(0 times) ~ 99(99 times)).

(c) Input Alarm

1) Average Value

A USINT type, which sets up the factor for the averaging filter. Setting range is (Weighted Average: 0(0%) ~99(99%), Moving Average 0(0 times) ~ 99(99 times)).

2) Up-Upper Limit

An INT type, which sets input up-upper limit alarm value to apply input alarm HYS. The setting range is between the lower to upper limit of scale within input range and above the low-lower and lower limit.

3) Upper limit

An INT type, which sets input upper limit alarm value to apply input alarm HYS. The setting range is between the lower to upper limit of scale within input range and above the low-lower and lower limit.

4) Lower Limit

An INT type, which sets input lower limit alarm value to apply input alarm HYS. The setting range is between the lower to upper limit of scale within input range and below the up-upper and upper limit.

5) Low-Lower Limit

An INT type, which sets input low-lower limit alarm value to apply input alarm HYS. The setting range is between the lower to upper limit of scale within input range and below the up-upper and upper limit.

6) Alarm HYS

A USINT type, which sets the hysteresis to be used commonly for the 4 input alarms (up-upper, upper, lower, low-lower limits). Setting range is between [Scale Upper Limit] - [Scale Lower Limit].

(3) Control Parameter

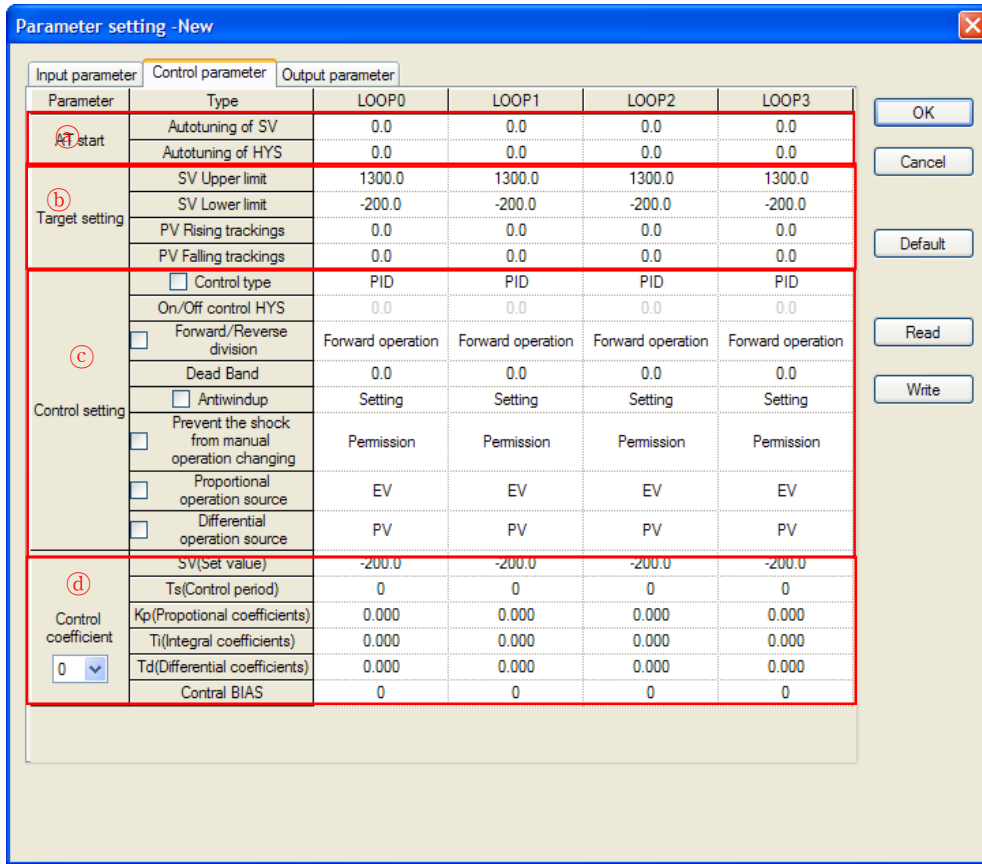

(a) Auto Tuning

1) Auto Tuning SV

An INT type, which sets up the SV value for use in Auto Tuning. By setting different value from SV, overshoot in Auto Tuning can be prevented. Setting range is between the Effective Input Upper Limit ~ Effective Input Lower Limit.

2) Auto Tuning HYS

A USINT type, which sets up the hysteresis to be applied in Auto Tuning. Setting range is between the 'SV Upper Limit ~ SV lower Limit.'

(b) Target Setting

1) SV Upper Limit

An INT type, which sets up the upper limit of the SV[Control Target]. Setting range is between the Effective Input Upper Limit ~ Effective Input Lower Limit and same or less than the SV Lower Limit.

2) SV Lower Limit

An INT type, which sets up the lower limit of the SV[Control Target]. Setting range is between the Effective Input Upper Limit ~ Effective Input Lower Limit and same or less than the SV Upper Limit.

3) PV Rise Tracking

A USINT type, which sets the SV as the current (PV + PV Rise Tracking) when SV has large difference from PV. Disables if the setting value is 0. Setting range is between Scale Upper Limit and Scale Lower Limit.

- 4) PV Fall Tracking

A USINT type, which sets the SV as the current (PV - PV Rise Tracking) when SV has large difference from PV. Disables if the setting value is 0. Setting range is between Scale Upper Limit and Scale Lower Limit.
- (c) Control Setting
 - 1) Control Type

Select PID, CASCADE, or On-Off control.
 - 2) ON/OFF Control HYS

A USINT type, which sets the hysteresis for use in ON-OFF type control. Setting range is between Scale Upper Limit and Scale Lower Limit.
 - 3) Normal-Reverse Classification

Normal operation is defines as the system where heating output has to be increased to raise the PV, and the reverse operation is defines as the system where heating output has to be increased to lower the PV.
 - 4) Blind Sector (Dead Zone)

A USINT type, which sets up the upper-lower SV blind sector (dead zone) radius. Setting range is between Input Upper Limit and Input Lower Limit.
 - 5) Anti Reset Wind-up

Prevents overshoot with anti reset wind up which may be caused by starting up, disturbance, or sudden change of SV.
 - 6) Shockproof Manual-to-Auto Change

Protects drive gear by mitigating impact in changing from manual to automatic operation.
 - 7) Proportional Operation Source

Selects the source for use in proportional operation. If PV is set up as the proportional operation source, anti reset wind up function may fail. If the function fail, block the function.
 - 8) Differential Operation Source

Selects the source for use in differential operation. If PV is set up as the differential operation source, smoother result can be obtained.
- (d) Control Coefficients
 - 1) SV[Control Target]

An INT type, which sets up the desired control target value. Setting range is between SV Upper Limit and SV Lower Limit.
 - 2) Ts[Control Period]

Sets up operation period. However, if set to 0, it is recognized as 1(200msec). Setting range is 1(200msec) ~ 65535(13107sec) or 0(200msec).
 - 3) Kp[Proportional Coefficient]

A REAL(float) type, which sets up proportional coefficient. Setting range is 0.0 ~ 100.0 and negative numbers cannot be entered.

4) Ti[Integral Coefficient]

A REAL(float) type, which sets up the coefficient of integration. Can be set up with any real number. Integration speed is proportional to this coefficient. Recommended setting range is 0(0.0) ~ 500(50.) and negative numbers cannot be entered.

5) Td[Differential Coefficient]

A REAL(float) type, which sets up the differential coefficient. Can be set up with any real number. Setting range is 0.0 ~ 0.1.

6) Control BIAS

An INT type, which sets up the bias to the load side transmit MV after control operation. Setting range is -1000 ~ 1000.

(4) Output Parameters

Input parameter		Control parameter		Output parameter			
Parameter	Type	LOOP0	LOOP1	LOOP2	LOOP3		
(a) Output setting	<input type="checkbox"/> Heating/cooling selection	Heating	Heating	Heating	Heating		
	Cooling power ratio	100	100	100	100		
(b) Heating output	<input type="checkbox"/> Output type	Analog Output	Analog Output	Analog Output	Analog Output		
	PWM period	5.0	5.0	5.0	5.0		
	Output upper limit	100.00	100.00	100.00	100.00		
	Output lower limit	0.00	0.00	0.00	0.00		
	Output change limit	100.00	100.00	100.00	100.00		
	Output standards	0.00	0.00	0.00	0.00		
	Manual output value	0.00	0.00	0.00	0.00		
	<input type="checkbox"/> Abnormal condition output	0mA	0mA	0mA	0mA		
(c) Cooling output	<input type="checkbox"/> Output type	Analog Output	Analog Output	Analog Output	Analog Output		
	PWM period	5.0	5.0	5.0	5.0		
	Output upper limit	100.00	100.00	100.00	100.00		
	Output lower limit	0.00	0.00	0.00	0.00		
	Output change limit	100.00	100.00	100.00	100.00		
	Output standards	0.00	0.00	0.00	0.00		
	Manual output value	0.00	0.00	0.00	0.00		
	<input type="checkbox"/> Abnormal condition output	0mA	0mA	0mA	0mA		
(c) Output alarm	Heating upper limit	100.00	100.00	100.00	100.00		
	Heating lower limit	0.00	0.00	0.00	0.00		
	Cooling upper limit	100.00	100.00	100.00	100.00		
	Cooling lower limit	0.00	0.00	0.00	0.00		
	Alarm HYS	0.00	0.00	0.00	0.00		

(a) Output Setting

1) Heating Cooling Selection

Sets up the operation of the heating output terminal, cooling output terminal, and heating/cooling output terminal.

2) Cooling Output Ratio

A USINT type, which sets up the cooling output creation ratio to heating output. Setting range is 0(0%) ~ 100(100%).

(b) Heating/Cooling Output

1) Output Type

Sets up the output type of the Heating/Cooling output terminal. Analog setting will provide 4 ~ 20mA, or PWM setting will provide pulse output.

2) PWM Period

A USINT type, which sets up the pulse output period used in PWM output. Setting range is 5(0.5sec) ~ 1200(120.0sec).

3) Output Upper Limit

An INT type, which sets up the upper limit value of heating/cooling output. Setting range is -5 ~ 105 for analog or 0 ~ 100 for PWM, above output lower limit.

4) Output Lower Limit

An INT type, which sets up the lower limit value of heating/cooling output. Setting range is -5 ~ 105 for analog or 0 ~ 100 for PWM, below output upper limit.

5) Output Variation Rate Limit

A USINT type, which sets up the allowable range of per period rise and fall of heating/cooling output. Setting range is -5 ~ 105 for analog or 0 ~ 100 for PWM, above the lower limit of heating output.

6) Output Reference

An INT type, which adjusts the reference of the heating/cooling output. Setting range is -5000(-50.00) ~ 5000(50.00).

7) Manual Output Value

An INT type, which sets up the output value of heating/cooling in manual mode.

8) Abnormal Condition Output

Sets up the output value under abnormal condition. 0mA, Minimum, Median or Maximum can be selected.

(c) Output Alarm

1) Heating Upper Limit

An INT type, which sets up the upper limit of heating output. Setting range is 0(0.00) ~ 100(100.00).

2) Heating Lower Limit

An INT type, which sets up the lower limit of heating output. Setting range is 0(0.00) ~ 100(100.00).

3) Cooling Upper Limit

An INT type, which sets up the upper limit of cooling output. Setting range is 0(0.00) ~ 100(100.00).

4) Cooling Lower Limit

An INT type, which sets up the lower limit of cooling output. Setting range is 0(0.00) ~ 100(100.00).

5) Alarm HYS

A USINT type, which sets up the hysteresis used for heating and cooling alarm. Setting range is 0(0.00) ~ 100(100.00).

7.3.9 Connection Setting

User can set up connection between PLC and XG-TCON in this dialog box.

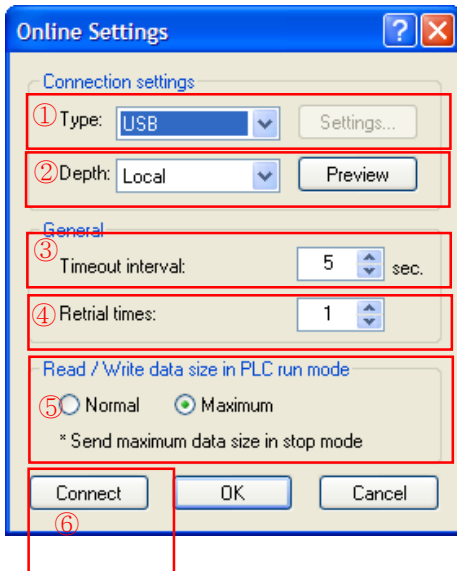

(1) Connection Method

Sets up connection method with PLC. RS-232C, USB, Ethernet, and Modem connection are supported. The three connection methods except the USB need further setting by selecting [Setting].

(2) Connection Steps

Sets up connection steps with PLC, which can be local, remote 1 step, or remote 2 steps. Select [View] to see the image of the connection step.

(3) Timeout at Communication Failure

Timeout is triggered if communication with PLC fails to be resumed within the set up time.

(4) Number of Retrials at Communication Failure

Sets up the number of retrials at communication failure with PLC.

(5) Read/Write Data Size in Run Mode

Sets up the size of the data transmission frame. This option applies only when the PLC operation is in RUN mode. In other modes, data is transmitted at the largest frame size.

7.3.10 Customize

This function enables to created new tool bar, or show or hide tool bar.

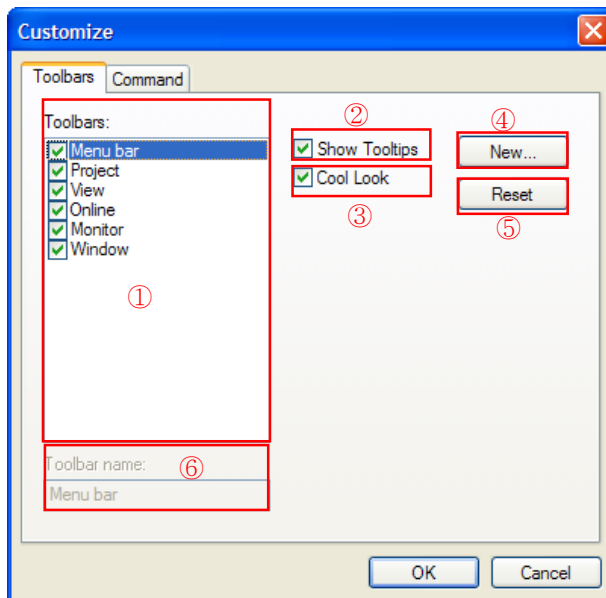

- (1) Tools (tool bar)
Checking/unchecking the check box in front of the items shows/hides the respective item.
- (2) Show Tool Tip
If checked, name of the tool bar will be displayed when mouse cursor is placed on the tool bar registered in the menu.
- (3) Cool Type
If checked, the boundary between tool bars is displayed.
- (4) New Tools
Creates new tool bars.
- (5) Reset
After modifying tool bar, clicking Reset will initialize the tool bars.
If mouse cursor is placed on the tool bar created with [New Tools], [Reset] will be changed to [Delete], selecting which will delete the new tool bar.
- (6) Tool Bar Name
Shows the name of the selected tool bar. If the tool bar created with [New Tools] is selected, its name can be changed here.

7.3.11 Option Dialog

Basic options of project can be set up in this dialog.

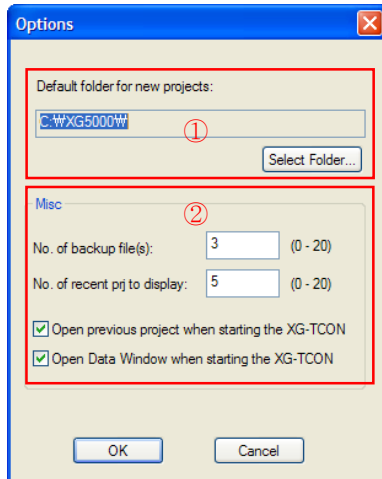

(1) Default Folder for Newly Created Project

Designates the default folder which will be created in addition to the new project. User cannot enter the folder name, but use [Find] menu to designate it.

(2) Others

[No. of Backup Files]: number of backup files can be set up.

[Show Recent Project Files]: number of the files to be indicated for the recent project can be defined.

[Open Previous Project at Start-up]: if checked, the previous project is opened at starting up the XG-TCON.

[Open Data Monitoring Window at Start-up]: if checked, data monitoring window is activated when new project is created.

7.3.12 Graph Setting

Display configuration of the trend monitoring window can be set up in this dialog.

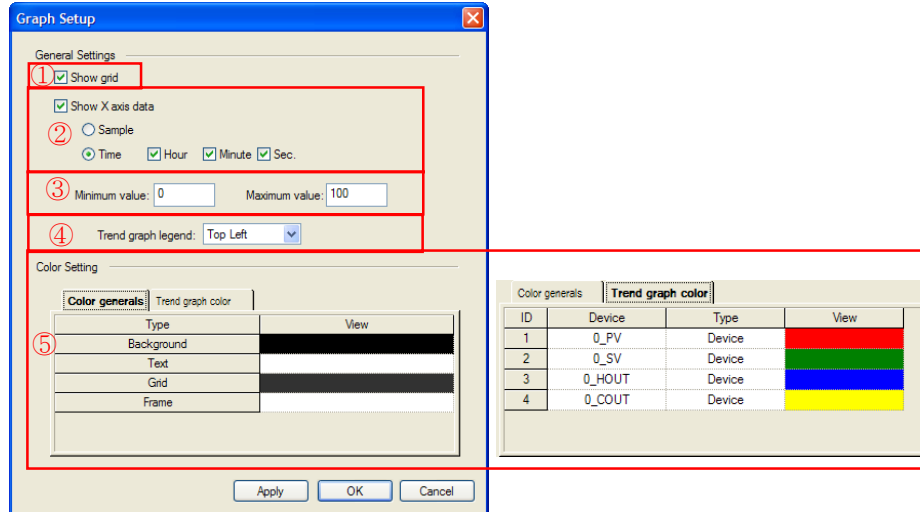

(1) Show Grid

Show/hide grid of the trend monitoring screen.

(2) Show X-axis Data

Show/hide X-axis data, and X-axis data can be displayed by the No. of samples or time.

(3) Min., Max. Graph Value

Minimum and maximum values of the Y-axis in the graph for zoom in/out can be set up.

(4) Trend Graph Index Position

The default position of the trend graph index is top left screen, which can be changed.

(5) Color Setting

Using the graph color general and trend graph color tab, graph or trend graph color can be selected.

7.3.13 Trend Setting

Trend monitoring operation can be set up in this dialog.

The PV(IN), SV, HOUT, and COUT of each loop can be easily registered, or view in graphs by selecting with check marks.

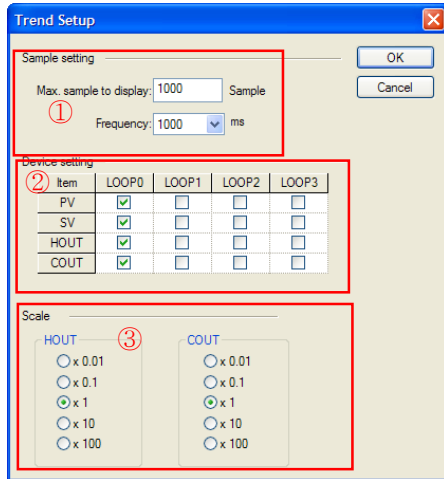

(1) Sample Setting

Maximum number of the samples indicated on the X-axis and the monitoring cycle can be set up. No. of samples is between 10 ~ 65535, and the cycle can be 200ms, 300ms, 400ms, 500ms, 1000ms, 2000ms, 3000ms, 4000ms, or 5000ms.

(2) Register Devices

The devices shown in the trend graph can be selected.

(3) Magnificent

The magnificent of HOUT and COUT can be set up. The HOUT and COUT are zoomed in/out regardless of the graph setting.

7.3.14 Logging Data Setting

The location and point of time at which the data sampled from trend monitor are saved in a file.

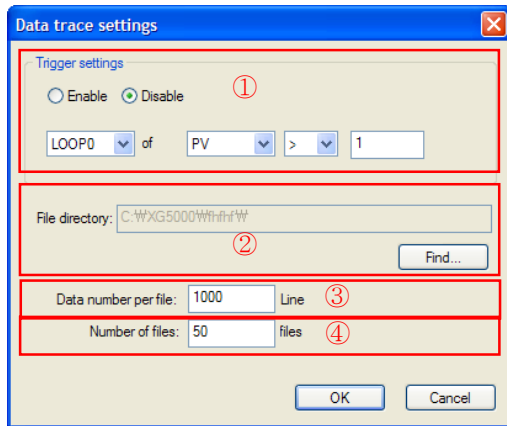

(1) Auto Start-up Condition

Sets up automatic starting conditions. If [Prohibit] is selected, auto start-up condition is saved without writing. If [Apply] is selected, automatic saving begins if the conditions are the same as those of the respective loop.

(2) File Location

Specifies the location (folder) for data saving using [Find] menu. The default folder is the folder where the present project is stored.

(3) No. of Data per File

Specifies number of data to be saved in a file, from minimum one line to maximum 10,000 lines.

(4) No. of Files for Continuous Saving

Specifies the number of files for saving, from minimum one to maximum 100.

7.3.15 Error Code

- The software package provides following error codes.

Error	Description of Error	RUN_LED
10	ASIC internal register initialization error	0.2s flicker
11	ASIC internal RAM read/write error	0.2s flicker
12	ASIC internal register read/write error	0.2s flicker
20	Backup memory checksum error	0.2s flicker
30	Overtime in access from module to refresh write area	0.2s flicker
31	Address error in access from module to refresh write area	0.2s flicker
32	Overtime in access from module to refresh read area	0.2s flicker
33	Address error in access from module to refresh read area	0.2s flicker
40	PLC CPU error	1s flicker
50	Parameter setting range excess error	1s flicker
60	AD converter H/W error	1s flicker
90	Input line open	1s flicker
100	Input type setting error	1s flicker
101	Effective input upper limit setting error	1s flicker
102	Effective input lower limit setting error	1s flicker
111	Input BIAS setting error	1s flicker
112	Average setting error	1s flicker
120	Input alarm up-upper limit setting error	1s flicker
121	Input alarm upper limit setting error	1s flicker
122	Input alarm lower limit setting error	1s flicker
123	Input alarm low-lower limit setting error	1s flicker
124	Alarm HYS setting error	1s flicker
200	Auto Tuning SV setting error	1s flicker
201	Auto Tuning HYS setting error	1s flicker

Error Code	Description of Error	RUN_LED
210	SV upper limit setting error	1s flicker
211	SV lower limit setting error	1s flicker
212	PV rise tracking setting error	1s flicker
223	PV fall tracking setting error	1s flicker
220	Control type setting error	1s flicker
221	ON/OFF control HYS setting error	1s flicker
222	Blind sector (dad zone) setting error	1s flicker
240+10n	SV(control target) setting error	1s flicker
241+10n	Kp(P-coefficient) setting error	1s flicker
242+10n	Ti(I-coefficient) setting error	1s flicker
243+10n	Td(D-coefficient) setting error	1s flicker
244+10n	Control bias setting error	1s flicker
230	Control coefficient setting error	1s flicker
310	Heating output PWM cycle setting error	1s flicker
311	Heating output upper limit setting error	1s flicker
312	Heating output lower limit setting error	1s flicker
313	Heating output variation limit setting error	1s flicker
314	Heating output reference setting error	1s flicker
315	Heating output manual value setting error	1s flicker
316	Heating output abnormal output setting error	1s flicker
320	Cooling output PWM cycle setting error	1s flicker
321	Cooling output upper limit setting error	1s flicker
322	Cooling output lower limit setting error	1s flicker
323	Cooling output variation limit setting error	1s flicker
324	Cooling output reference setting error	1s flicker
325	Cooling output manual value setting error	1s flicker
326	Cooling output abnormal output setting error	1s flicker
330	Heating upper limit setting error	1s flicker
331	Heating lower limit setting error	1s flicker
332	Cooling upper limit setting error	1s flicker
333	Cooling lower limit setting error	1s flicker
334	Alarm HYS setting error	1s flicker

※ n stands for the control coefficient

Chapter 8 Programming (for XGK)

8.1 Pre-operation Setting-up Procedure

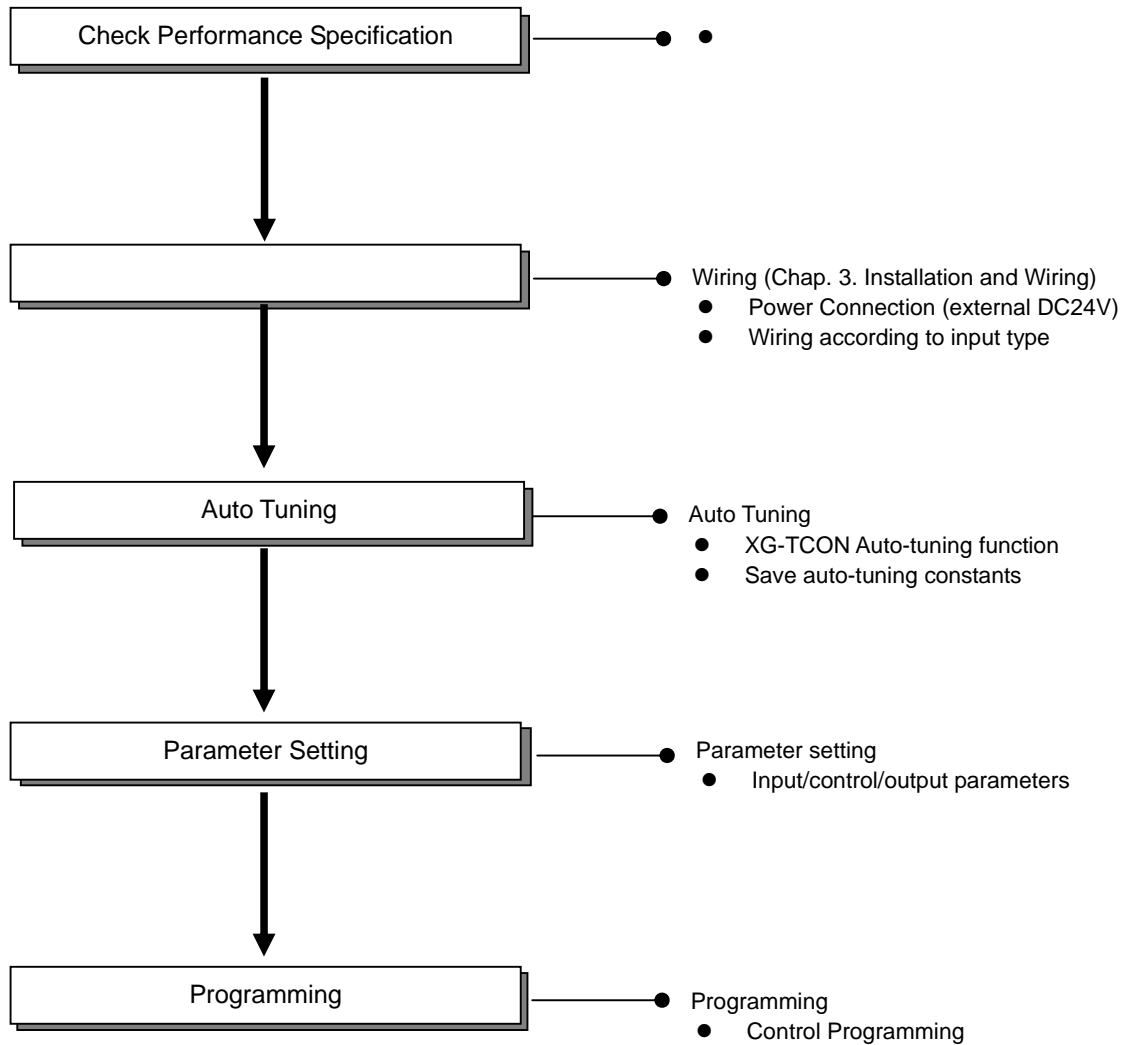

8.2 Sample Program

- Below is a sample program for temperature control with a temperature controller mounted in slot #2.

8.2.1 Auto Tuning

- This section describes auto tuning method.

- (1) In the XG-TCON software window, select [Connect] after creating a new project.

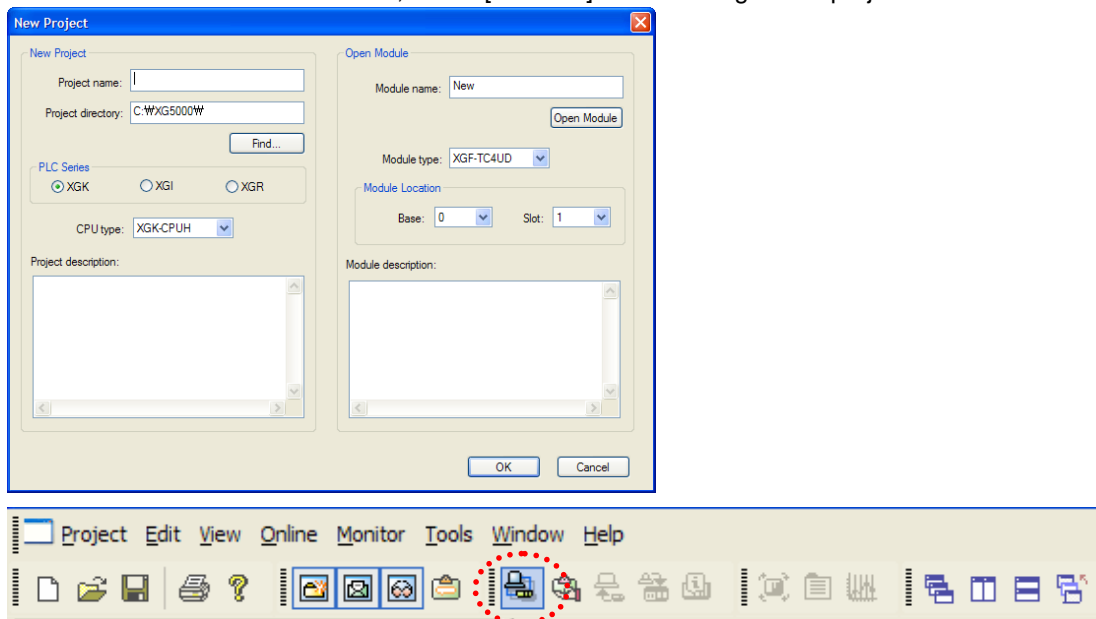

- (2) In the project window, select Input Parameter to call parameter setting window shown below.

The image shows the 'Parameter setting -New' dialog box. It has tabs for 'Input parameter', 'Control parameter', and 'Output parameter'. The 'Input parameter' tab is active, showing a table of parameters for four loops (LOOP0, LOOP1, LOOP2, LOOP3). The 'LOOP2' column has a dropdown menu open, showing 'Pt100: -200 ~ 850'. On the right side of the dialog, there are buttons for 'OK', 'Cancel', 'Default', 'Read', and 'Write'.

Parameter	Type	LOOP0	LOOP1	LOOP2	LOOP3
Input type	<input type="checkbox"/> Input type	Pt100: -200 ~ 850	Pt100: -200 ~ 850	Pt100: -200 ~ 850	Pt100: -200 ~ 850
	<input type="checkbox"/> Short circuit	Permission	Permission	Permission	Permission
	Upper limit of effective input	850.0	850.0	850.0	850.0
	Lower limit of effective input	-200.0	-200.0	-200.0	-200.0
	Upper limit of scale	850.0	850.0	850.0	850.0
	Lower limit of scale	-200.0	-200.0	-200.0	-200.0
Input process	Input BIAS	0.0	0.0	0.0	0.0
	<input type="checkbox"/> Average type	Weighted average	Weighted average	Weighted average	Weighted average
	Average value	0	0	0	0
Input alarm	High upper limit	850.0	850.0	850.0	850.0
	Upper limit	850.0	850.0	850.0	850.0
	Lower limit	-200.0	-200.0	-200.0	-200.0
	Low lower limit	-200.0	-200.0	-200.0	-200.0
Alarm HYS	0.0	0.0	0.0	0.0	

- (3) In the parameter setting window, set up input and output types. Select Write button to save the parameter setting in the temperature controller.
- (4) In the operation reference window in bottom left, select the operation of the respective loop and select Start Auto Tuning.

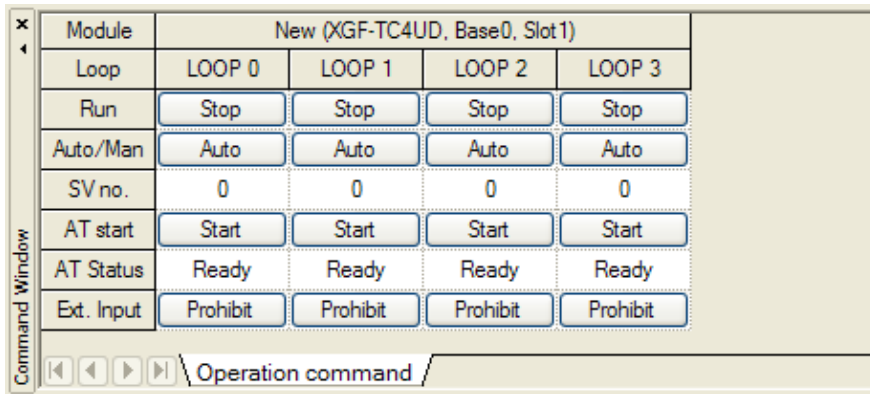

- (5) When “Completed” appears in the tuning section, open the #2 parameter setting window and select Write button to save the auto tuning constants in the temperature controller.

8.2.2 Temperature Control Program

- Below is an exemplary system where, the temperature of the temperature control chamber is measured with the T-type thermocouple connected to loop 0, and perform heating/cooling output control to maintain the temperature in the chamber at $200^{\circ}\text{C} \pm 10^{\circ}\text{C}$.

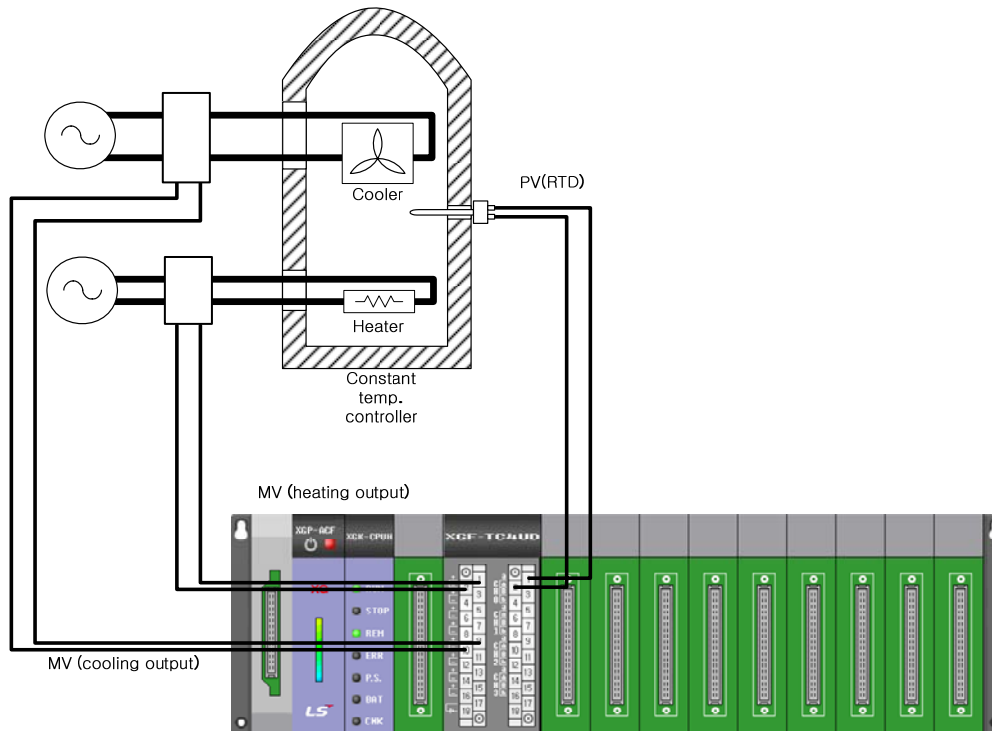

Chap. 8 Programming (for XGK)

(1) Input Parameter Setting

- Select T-type of the thermocouple for the input type of the LOOP0.

Input parameter	Control parameter	Output parameter
Parameter	Type	LOOP0
Input type	<input type="checkbox"/> Input type	Pt 100: -200 ~ 850
	<input type="checkbox"/> Short circuit	Permission
	Upper limit of effective input	850.0
	Lower limit of effective input	-200.0
	Upper limit of scale	850.0
	Lower limit of scale	-200.0

(2) Control Parameter Setting

- Set the dead band to 100(10.0 °C)
- Set the SV (control target) to 2000(200.0 °C)
- Set the Kp (proportional coefficient) to 1000(1.000)
- Set the Ti (integral coefficient) to 1000(1.000)
- When using auto tuning, set up with the value detected by auto tuning

Input parameter	Control parameter	Output parameter
Parameter	Type	LOOP0
AT start	Autotuning of SV	0.0
	Autotuning of HYS	0.0
Target setting	SV Upper limit	400.0
	SV Lower limit	-200.0
	PV Rising trackings	0.0
	PV Falling trackings	0.0
Control setting	<input type="checkbox"/> Control type	PID
	On/Off control HYS	0.0
	<input type="checkbox"/> Forward/Reverse division	Forward operation
	Dead Band	10.0
	<input type="checkbox"/> Antiwindup	Setting
	<input type="checkbox"/> Prevent the shock from manual operation changing	Permission
	<input type="checkbox"/> Proportional operation source	EV
	<input type="checkbox"/> Differential operation source	PV
Control coefficient	SV(Set value)	200.0
	Ts(Control period)	0
	Kp(Proportional coefficients)	1.000
	Ti(Integral coefficients)	1.000
	Td(Differential coefficients)	0.000
	Control BIAS	0

(3) Output Parameter Setting

- In the output setting, select Heating/Cooling.

Input parameter	Control parameter	Output parameter				
Parameter	Type	LOOP0	LOOP1	LOOP2	LOOP3	
Output setting	<input type="checkbox"/> Heating/cooling selection	Heating/Cooling	Heating	Heating	Heating	
	Cooling power ratio	100	100	100	100	

(4) Operation

- Select Connect from online menu, and select Write in the (3) Parameter Setting Window.

Input parameter		Control parameter	Output parameter			
Parameter	Type	LOOP0	LOOP1	LOOP2	LOOP3	
Input type	<input type="checkbox"/> Input type	T: -200 ~ 400 deg.	K: -200 ~ 1300 deg.	K: -200 ~ 1300 deg.	K: -200 ~ 1300 deg.	<input type="button" value="OK"/> <input type="button" value="Cancel"/> <input type="button" value="Default"/> <input type="button" value="Read"/> <input type="button" value="Write"/>
	<input type="checkbox"/> Short circuit	Permission	Permission	Permission	Permission	
	Upper limit of effective input	400.0	1300.0	1300.0	1300.0	
	Lower limit of effective input	-200.0	-200.0	-200.0	-200.0	
	Upper limit of scale	400.0	1300.0	1300.0	1300.0	
	Lower limit of scale	-200.0	-200.0	-200.0	-200.0	
	<input type="checkbox"/> Decial point of scale value	1	1	1	1	
Input process	<input type="checkbox"/> Square root	Prohibit	Prohibit	Prohibit	Prohibit	
	LOW CUT	0.0	0.0	0.0	0.0	
	Input BIAS	0.0	0.0	0.0	0.0	
	<input type="checkbox"/> Average type	Weighted average	Weighted average	Weighted average	Weighted average	
	Average value	0	0	0	0	

- After writing, select Stop of loop0 from the operation command in the module state window to change to the operation state.

Module	LOOP 0	LOOP 1	LOOP 2	LOOP 3
Loop				
Run	<input type="button" value="Stop"/>	<input type="button" value="Stop"/>	<input type="button" value="Stop"/>	<input type="button" value="Stop"/>
Auto/Man	<input type="button" value="Auto"/>	<input type="button" value="Auto"/>	<input type="button" value="Auto"/>	<input type="button" value="Auto"/>
SV no.	0	0	0	0
AT start	<input type="button" value="Start"/>	<input type="button" value="Start"/>	<input type="button" value="Start"/>	<input type="button" value="Start"/>
AT Status	Ready	Ready	Ready	Ready
Ext. Input	<input type="button" value="Prohibit"/>	<input type="button" value="Prohibit"/>	<input type="button" value="Prohibit"/>	<input type="button" value="Prohibit"/>

- The temperature controller will provide cooling output (Ch 1) when the present temperature exceeds 200°C, or heating output (Ch 0) when the present temperature is below 200°C.

(5) Data Monitor

- Select [Monitor]-[Data Monitor] to check control status.

Chap. 8 Programming (for XGK)

	Type	LOOP 0	LOOP 1	LOOP 2	LOOP 3
Operation information	Sensor input	[Bum-out]	0.0 °C	0.0 °C	0.0 °C
	Operation	Run	Stop	Stop	Stop
	Automatic/Manual operation	Auto	Auto	Auto	Auto
	Control setting	0	0	0	0
	Automatic tuning status	Ready	Ready	Ready	Ready
	Operation error	[70]	Normal	Normal	Normal
Alarm condition	LOW CUT Operation	Prohibit	Prohibit	Prohibit	Prohibit
	Input High upper limit	Normal	Normal	Normal	Normal
	Input upper limit	Normal	Normal	Normal	Normal
	Input lower limit	Alarm	Normal	Normal	Normal
	Input Low lower limit	Alarm	Normal	Normal	Normal
	Heating upper limit	Normal	Normal	Normal	Normal
	Heating lower limit	Alarm	Normal	Normal	Normal
Control information	Cooling upper limit	Normal	Normal	Normal	Normal
	Cooling lower limit	Normal	Normal	Normal	Normal
	Control type	PID	PID	PID	PID
	Forward/Reverse operation	Forward	Forward	Forward	Forward
	PV(Control Input)	[Bum-out]	0.0 °C	0.0 °C	0.0 °C
	SV(Control target)	-200.0 °C	0.0 °C	0.0 °C	0.0 °C
	PV rising tracking	Prohibit	Prohibit	Prohibit	Prohibit
	PV falling tracking	Prohibit	Prohibit	Prohibit	Prohibit
	EV(Control error value)	0.000000	0.000000	0.000000	0.000000
Output information	Dead Band	Prohibit	Prohibit	Prohibit	Prohibit
	Prevention of nover-integral operation	Setting	Setting	Setting	Setting
	MV(Control output)	0.00	0.00	0.00	0.00
	Heating output type	Analog	Analog	Analog	Analog
	Heating output	0.00%	0.00%	0.00%	0.00%
Output information	Cooling output type	Analog	Analog	Analog	Analog
	Cooling output	0.00%	0.00%	0.00%	0.00%

8.2.3 Sample Program using PUT/GET Command

- Below is an exemplary program to change parameters using PUT/GET command.
- The U device contacts and description required for using PUT/GET command are as follows.

Device Name		Symbol Name	Description
Word	Bit		
U00.01	U00.01.0	_00_WR_ING	Parameter being saved (writing)
	Read only area which shows backup operation of the module. If the respective bit is On, the module data is being written for saving.		
	U00.01.8	_00_RD_ING	Parameter being retrieved (reading)
	Read only area which shows backup operation of the module. If the respective bit is ON, the module data is being retrieved.		
U00.30	U00.30.0	_00_WRITE	Parameter save command (write)
	U00.30.8	_00_READ	Parameter restore command (read)

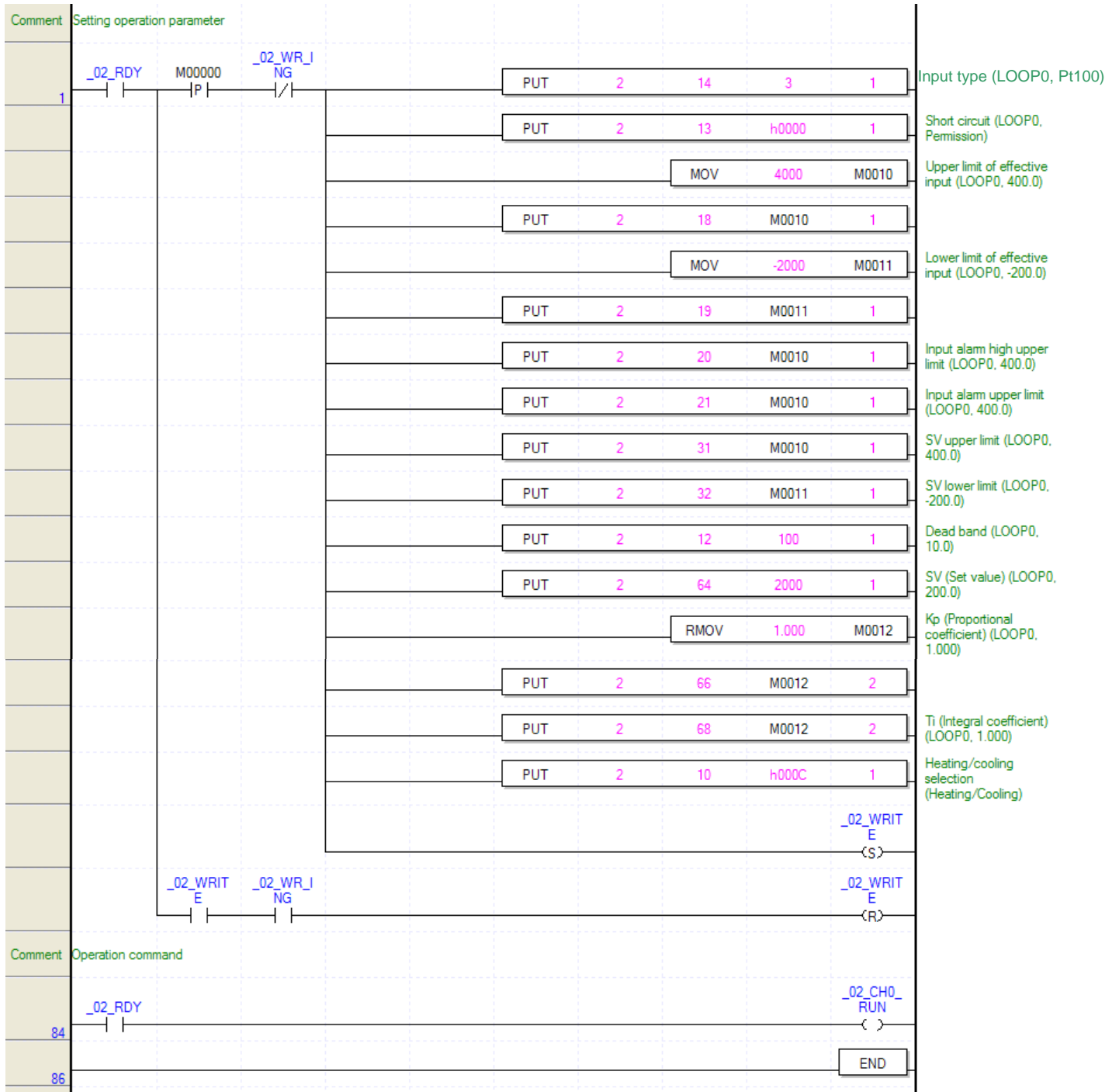

Chapter 9 Programming (for XGI/XGR)

9.1 Pre-operation Setting-up Procedure

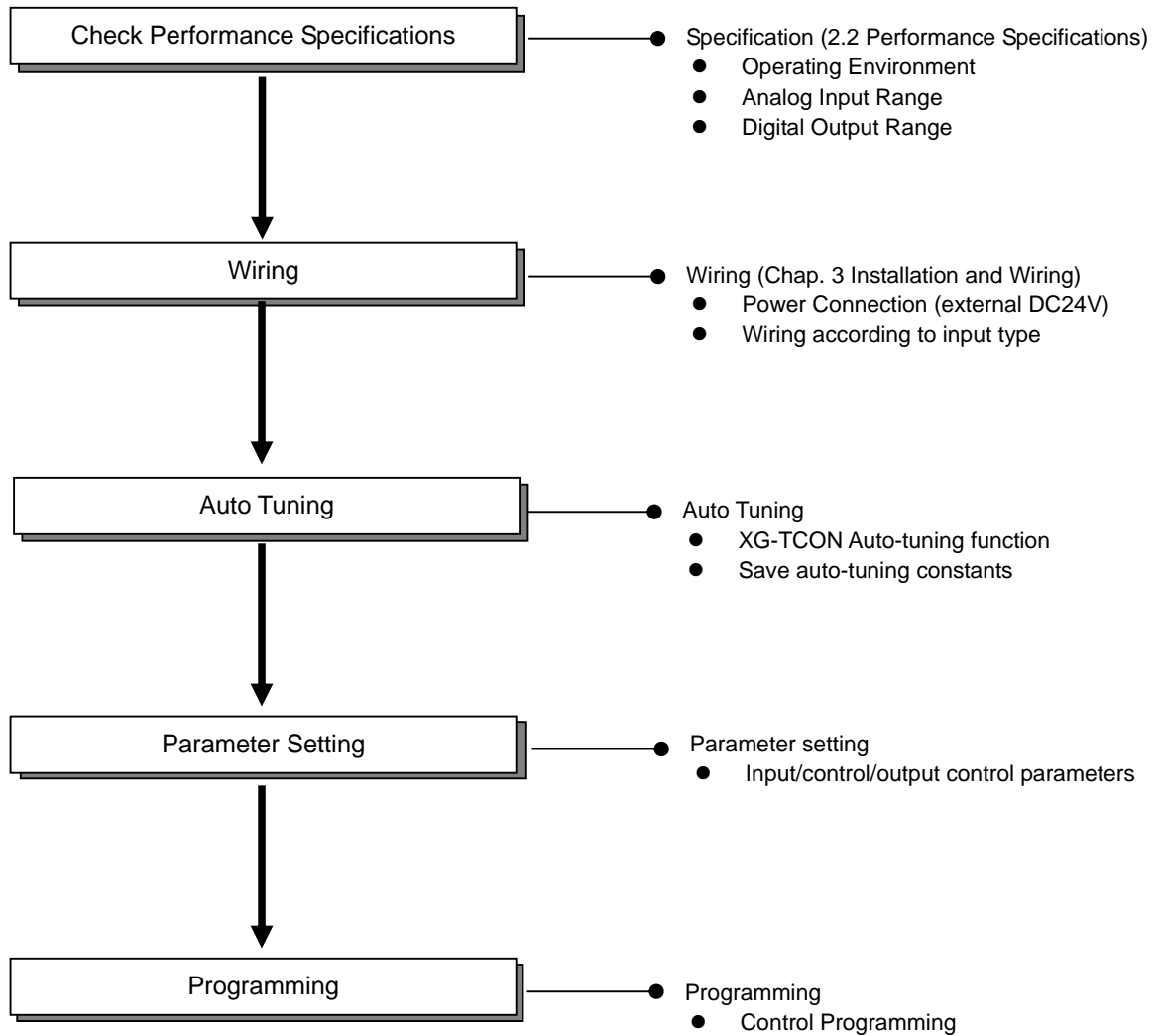

9.2 Sample Program

- Below is a sample program for temperature control with a temperature controller mounted in slot #2.

9.2.1 Auto Tuning

- This section describes auto tuning method.

- (1) In the XG-TCON software window, select [Connect] after creating a new project.

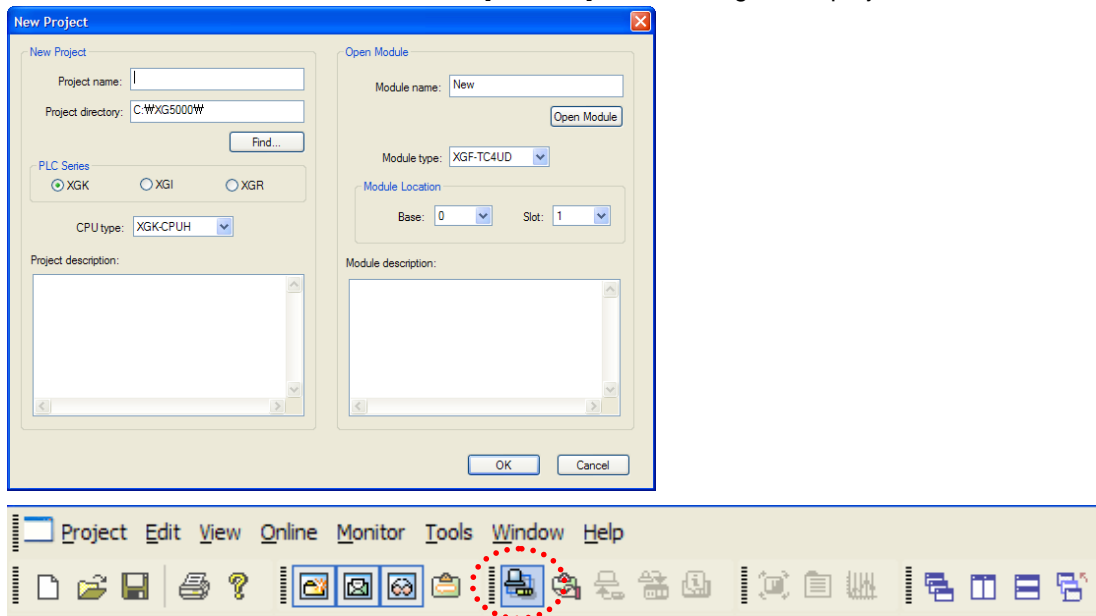

- (2) In the project window, select Input Parameter to call parameter setting window shown below.

The 'Parameter setting -New' dialog box displays a table of parameters for four loops (LOOP0, LOOP1, LOOP2, LOOP3). The table is organized into three main sections: Input parameter, Input process, and Input alarm. The 'Input parameter' section includes checkboxes for 'Input type' and 'Short circuit', and numerical values for 'Upper limit of effective input', 'Lower limit of effective input', 'Upper limit of scale', and 'Lower limit of scale'. The 'Input process' section includes checkboxes for 'Average type' and 'Average value'. The 'Input alarm' section includes numerical values for 'High upper limit', 'Upper limit', 'Lower limit', 'Low lower limit', and 'Alarm HYS'. The 'LOOP2' column has a dropdown menu set to 'Pt100: -200 ~ 850'. Buttons for 'OK', 'Cancel', 'Default', 'Read', and 'Write' are located on the right side of the dialog.

Parameter	Type	LOOP0	LOOP1	LOOP2	LOOP3
Input type	<input type="checkbox"/> Input type	Pt100: -200 ~ 850	Pt100: -200 ~ 850	Pt100: -200 ~ 850	Pt100: -200 ~ 850
	<input type="checkbox"/> Short circuit	Permission	Permission	Permission	Permission
	Upper limit of effective input	850.0	850.0	850.0	850.0
	Lower limit of effective input	-200.0	-200.0	-200.0	-200.0
	Upper limit of scale	850.0	850.0	850.0	850.0
Lower limit of scale	-200.0	-200.0	-200.0	-200.0	
Input process	<input type="checkbox"/> Input BIAS	0.0	0.0	0.0	0.0
	<input type="checkbox"/> Average type	Weighted average	Weighted average	Weighted average	Weighted average
Input alarm	Average value	0	0	0	0
	High upper limit	850.0	850.0	850.0	850.0
	Upper limit	850.0	850.0	850.0	850.0
	Lower limit	-200.0	-200.0	-200.0	-200.0
	Low lower limit	-200.0	-200.0	-200.0	-200.0
Alarm HYS	0.0	0.0	0.0	0.0	

- (3) In the parameter setting window, set up input and output types. Select Write button to save the parameter setting in the temperature controller.
- (4) In the operation reference window in bottom left, select the operation of the respective loop and select Start Auto Tuning.

Module		New (XGF-TC4UD, Base0, Slot1)			
Loop		LOOP 0	LOOP 1	LOOP 2	LOOP 3
Run		Stop	Stop	Stop	Stop
Auto/Man		Auto	Auto	Auto	Auto
SV no.		0	0	0	0
AT start		Start	Start	Start	Start
AT Status		Ready	Ready	Ready	Ready
Ext. Input		Prohibit	Prohibit	Prohibit	Prohibit

Command Window

⏪ ⏩ \ Operation command /

- (5) When “Completed” appears in the tuning section, open the #2 parameter setting window and select Write button to save the auto tuning constants in the temperature controller.

9.2.2 Temperature Control Program

- Below is an exemplary system where, the temperature of the temperature control chamber is measured with the Pt100 type RTD connected to loop 0, and perform heating/cooling output control to maintain the temperature in the chamber at $200^{\circ}\text{C} \pm 10^{\circ}\text{C}$.

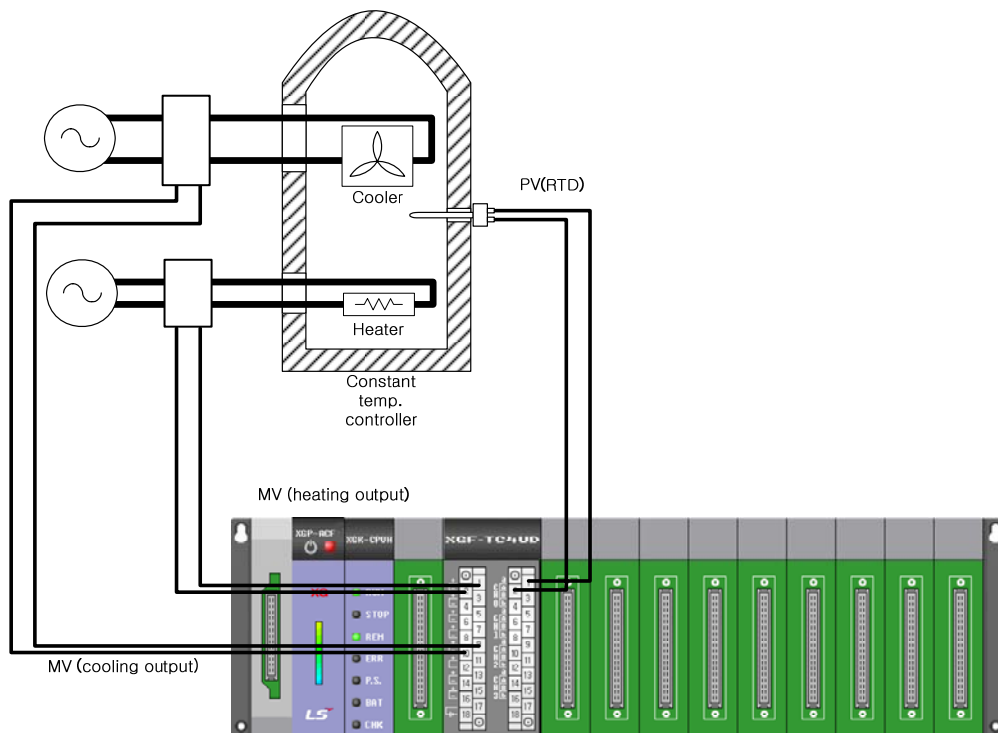

Chap. 9 Programming (for XGI/XGR)

(1) Input Parameter Setting

- Select Pt100type for the input type of the LOOP0.

Input parameter		Control parameter	Output parameter
Parameter	Type	LOOP0	
Input type	<input type="checkbox"/> Input type	Pt 100: -200 ~ 850	
	<input type="checkbox"/> Short circuit	Permission	
	Upper limit of effective input	850.0	
	Lower limit of effective input	-200.0	
	Upper limit of scale	850.0	
	Lower limit of scale	-200.0	

(2) Control Parameter Setting

- Set the deadband to 100(10.0°C)
- Set the SV (control target) to 2000(200.0°C)
- Set the Kp (proportional coefficient) to 1000(1.000)
- Set the Ti (integral coefficient) to 1000(1.000)
- When using auto tuning, set up with the value detected by auto tuning

Input parameter		Control parameter	Output parameter
Parameter	Type	LOOP0	
AT start	Autotuning of SV	0.0	
	Autotuning of HYS	0.0	
Target setting	SV Upper limit	400.0	
	SV Lower limit	-200.0	
	PV Rising trackings	0.0	
	PV Falling trackings	0.0	
Control setting	<input type="checkbox"/> Control type	PID	
	On/Off control HYS	0.0	
	<input type="checkbox"/> Forward/Reverse division	Forward operation	
	Dead Band	10.0	
	<input type="checkbox"/> Antiwindup	Setting	
	<input type="checkbox"/> Prevent the shock from manual operation changing	Permission	
	<input type="checkbox"/> Proportional operation source	EV	
	<input type="checkbox"/> Differential operation source	PV	
Control coefficient	SV(Set value)	200.0	
	Ts(Control period)	0	
	Kp(Proportional coefficients)	1.000	
	Ti(Integral coefficients)	1.000	
	Td(Differential coefficients)	0.000	
	Control BIAS	0	

(3) Output Parameter Setting

- In the output setting, select Heating/Cooling.

Input parameter		Control parameter	Output parameter			
Parameter	Type	LOOP0	LOOP1	LOOP2	LOOP3	
Output setting	<input type="checkbox"/> Heating/cooling selection	Heating/Cooling	Heating	Heating	Heating	
	Cooling power ratio	100	100	100	100	

(4) Operation

- Select Connect from online menu, and select Write in the (3) Parameter Setting Window.

Input parameter		Control parameter	Output parameter			
Parameter	Type	LOOP0	LOOP1	LOOP2	LOOP3	
Input type	<input type="checkbox"/> Input type	T: -200 ~ 400 deg.	K: -200 ~ 1300 deg.	K: -200 ~ 1300 deg.	K: -200 ~ 1300 deg.	<input type="button" value="OK"/> <input type="button" value="Cancel"/> <input type="button" value="Default"/> <input type="button" value="Read"/> <input type="button" value="Write"/>
	<input type="checkbox"/> Short circuit	Permission	Permission	Permission	Permission	
	Upper limit of effective input	400.0	1300.0	1300.0	1300.0	
	Lower limit of effective input	-200.0	-200.0	-200.0	-200.0	
	Upper limit of scale	400.0	1300.0	1300.0	1300.0	
	Lower limit of scale	-200.0	-200.0	-200.0	-200.0	
Input process	<input type="checkbox"/> Decial point of scale value	1	1	1	1	
	<input type="checkbox"/> Square root	Prohibit	Prohibit	Prohibit	Prohibit	
	LOW CUT	0.0	0.0	0.0	0.0	
	Input BIAS	0.0	0.0	0.0	0.0	
	<input type="checkbox"/> Average type	Weighted average	Weighted average	Weighted average	Weighted average	
	Average value	0	0	0	0	

- After writing, select Stop of loop0 from the operation command in the module state window to change to the operation state.

Module	LOOP 0	LOOP 1	LOOP 2	LOOP 3
Loop	LOOP 0	LOOP 1	LOOP 2	LOOP 3
Run	<input type="button" value="Stop"/>	<input type="button" value="Stop"/>	<input type="button" value="Stop"/>	<input type="button" value="Stop"/>
Auto/Man	<input type="button" value="Auto"/>	<input type="button" value="Auto"/>	<input type="button" value="Auto"/>	<input type="button" value="Auto"/>
SV no.	0	0	0	0
AT start	<input type="button" value="Start"/>	<input type="button" value="Start"/>	<input type="button" value="Start"/>	<input type="button" value="Start"/>
AT Status	Ready	Ready	Ready	Ready
Ext. Input	<input type="button" value="Prohibit"/>	<input type="button" value="Prohibit"/>	<input type="button" value="Prohibit"/>	<input type="button" value="Prohibit"/>

- The temperature controller will provide cooling output (Ch 1) when the present temperature exceeds 200 °C, or heating output (Ch 0) when the present temperature is below 200 °C.

(5) Data Monitor

- Select [Monitor]-[Data Monitor] to check control status.

Chap. 9 Programming (for XGI/XGR)

	Type	LOOP 0	LOOP 1	LOOP 2	LOOP 3
Operation information	Sensor input	[Burn-out]	0.0 °C	0.0 °C	0.0 °C
	Operation	Run	Stop	Stop	Stop
	Automatic/Manual operation	Auto	Auto	Auto	Auto
	Control setting	0	0	0	0
	Automatic tuning status	Ready	Ready	Ready	Ready
	Operation error	[70]	Normal	Normal	Normal
	LOW CUT Operation	Prohibit	Prohibit	Prohibit	Prohibit
Alarm condition	Input High upper limit	Normal	Normal	Normal	Normal
	Input upper limit	Normal	Normal	Normal	Normal
	Input lower limit	Alarm	Normal	Normal	Normal
	Input Low lower limit	Alarm	Normal	Normal	Normal
	Heating upper limit	Normal	Normal	Normal	Normal
	Heating lower limit	Alarm	Normal	Normal	Normal
	Cooling upper limit	Normal	Normal	Normal	Normal
Cooling lower limit	Normal	Normal	Normal	Normal	
Control information	Control type	PID	PID	PID	PID
	Forward/Reverse operation	Forward	Forward	Forward	Forward
	PV(Control Input)	[Burn-out]	0.0 °C	0.0 °C	0.0 °C
	SV(Control target)	-200.0 °C	0.0 °C	0.0 °C	0.0 °C
	PV rising tracking	Prohibit	Prohibit	Prohibit	Prohibit
	PV falling tracking	Prohibit	Prohibit	Prohibit	Prohibit
	EV(Control error value)	0.000000	0.000000	0.000000	0.000000
	Dead Band	Prohibit	Prohibit	Prohibit	Prohibit
	Prevention of nover-intergal operation	Setting	Setting	Setting	Setting
MV(Control output)	0.00	0.00	0.00	0.00	
Output information	Heating output type	Analog Output	Analog Output	Analog Output	Analog Output
	Heating output	0.00%	0.00%	0.00%	0.00%
	Cooling output type	Analog Output	Analog Output	Analog Output	Analog Output
	Cooling output	0.00%	0.00%	0.00%	0.00%

9.2.3 Sample Program

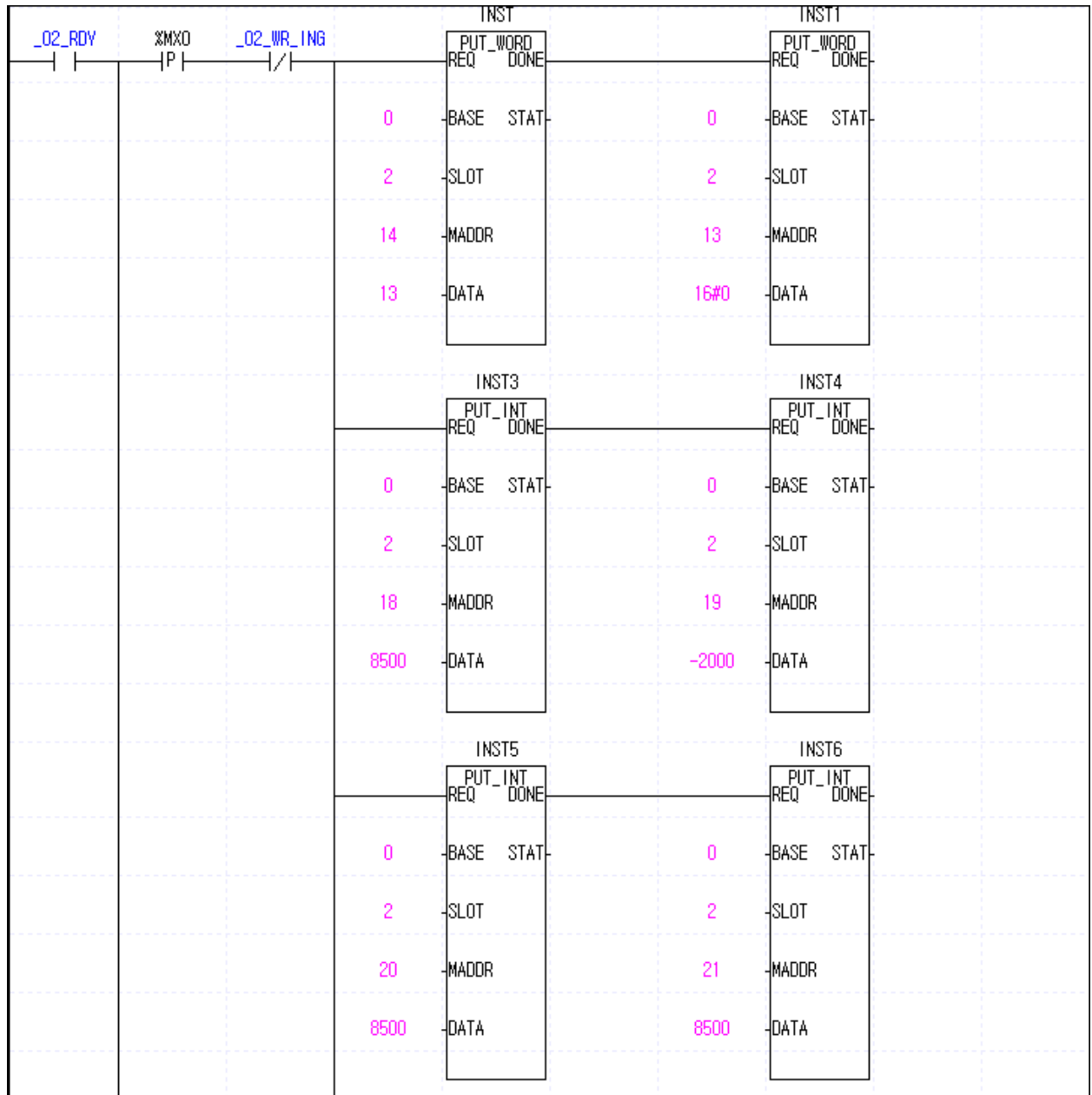

Chap. 9 Programming (for XGI/XGR)

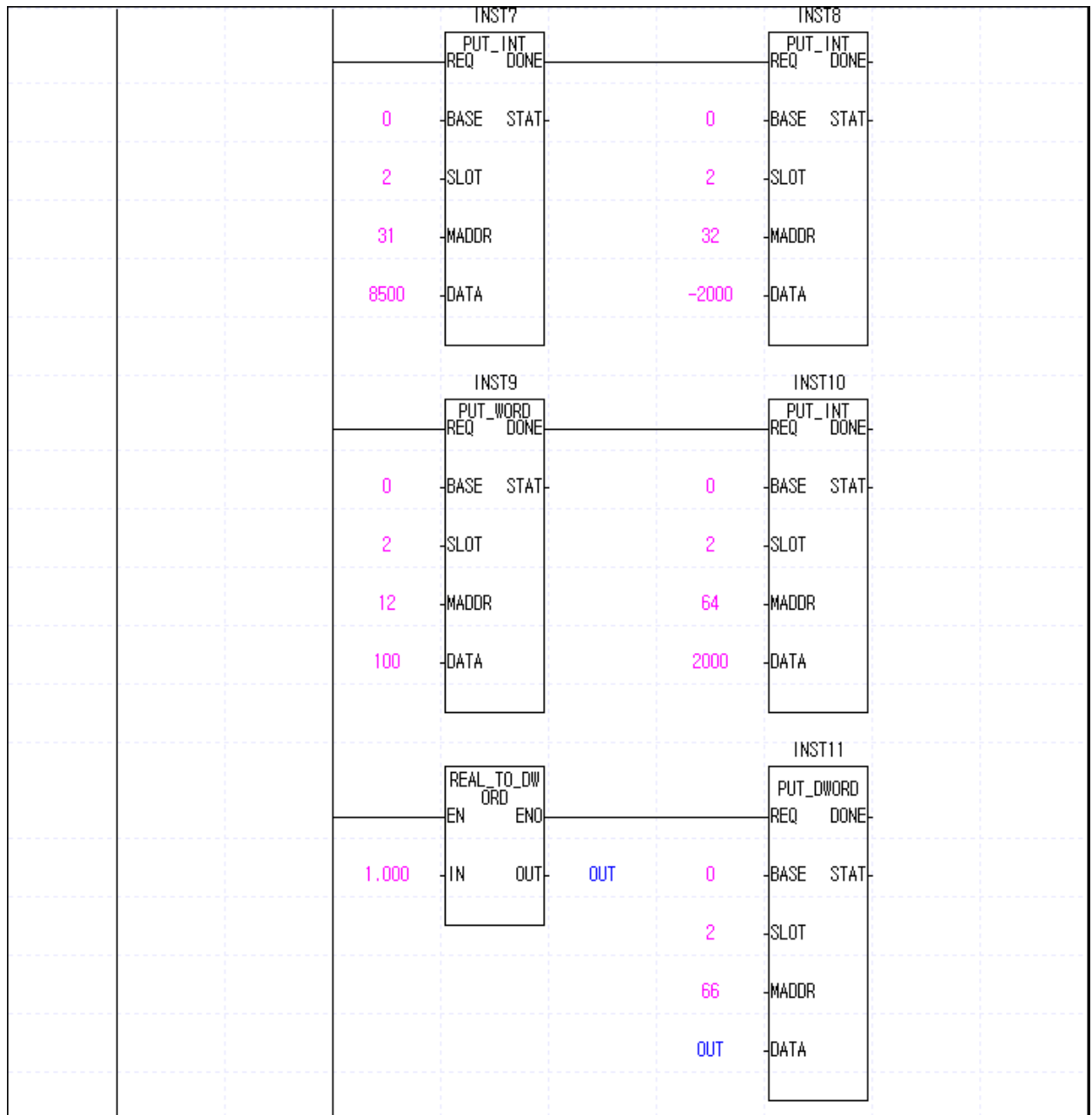

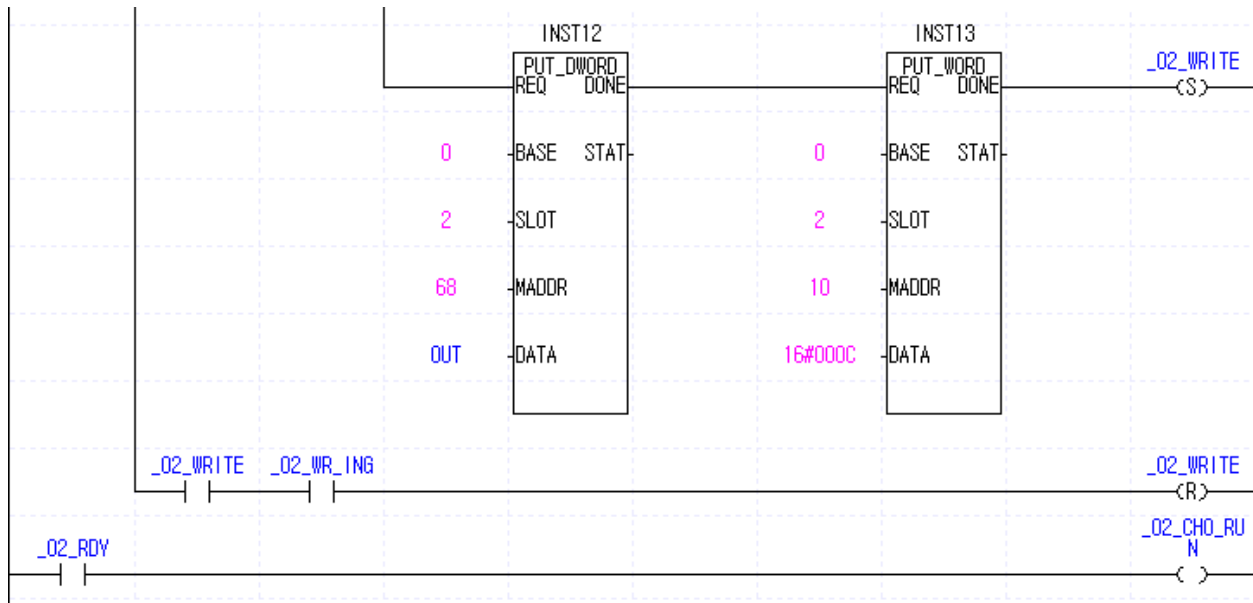

Chapter 10 Diagnosis

10.1 Error Code

[Table 10.1 Error code]

Error	Description of Error	RUN_LED
10	ASIC internal register initialization error	0.2s flicker
11	ASIC internal RAM read/write error	0.2s flicker
12	ASIC internal register read/write error	0.2s flicker
20	Backup memory checksum error	0.2s flicker
30	Overtime in access from module to refresh write area	0.2s flicker
31	Address error in access from module to refresh write area	0.2s flicker
32	Overtime in access from module to refresh read area	0.2s flicker
33	Address error in access from module to refresh read area	0.2s flicker
40	PLC CPU error	1s flicker
50	Parameter setting range excess error	1s flicker
60	AD converter H/W error	1s flicker
90	Input line open	1s flicker
100	Input type setting error	1s flicker
101	Effective input upper limit setting error	1s flicker
102	Effective input lower limit setting error	1s flicker
111	Input BIAS setting error	1s flicker
112	Average setting error	1s flicker
120	Input alarm up-upper limit setting error	1s flicker
121	Input alarm upper limit setting error	1s flicker
122	Input alarm lower limit setting error	1s flicker
123	Input alarm low-lower limit setting error	1s flicker
124	Alarm HYS setting error	1s flicker
200	Auto Tuning SV setting error	1s flicker
201	Auto Tuning HYS setting error	1s flicker

※ n stands for the loop number.

Error Code	Description of Error	RUN_LED
210	SV upper limit setting error	1s flicker
211	SV lower limit setting error	1s flicker
212	PV rise tracking setting error	1s flicker
223	PV fall tracking setting error	1s flicker
220	Control type setting error	1s flicker
221	ON/OFF control HYS setting error	1s flicker
222	Blind sector (dad zone) setting error	1s flicker
240+10n	SV(control target) setting error	1s flicker
241+10n	Kp(P-coefficient) setting error	1s flicker
242+10n	Ti(I-coefficient) setting error	1s flicker
243+10n	Td(D-coefficient) setting error	1s flicker
244+10n	Control bias setting error	1s flicker
230	Control coefficient setting error	1s flicker
310	Heating output PWM cycle setting error	1s flicker
311	Heating output upper limit setting error	1s flicker
312	Heating output lower limit setting error	1s flicker
313	Heating output variation limit setting error	1s flicker
314	Heating output reference setting error	1s flicker
315	Heating output manual value setting error	1s flicker
316	Heating output abnormal output setting error	1s flicker
320	Cooling output PWM cycle setting error	1s flicker
321	Cooling output upper limit setting error	1s flicker
322	Cooling output lower limit setting error	1s flicker
323	Cooling output variation limit setting error	1s flicker
324	Cooling output reference setting error	1s flicker
325	Cooling output manual value setting error	1s flicker
326	Cooling output abnormal output setting error	1s flicker
330	Heating upper limit setting error	1s flicker
331	Heating lower limit setting error	1s flicker
332	Cooling upper limit setting error	1s flicker
333	Cooling lower limit setting error	1s flicker
334	Alarm HYS setting error	1s flicker

※ n stands for the loop number.

10.2 Diagnosis

10.2.1 RUN LED is OFF

Checklist	Action
Is the temperature module correctly installed in the base?	Install temperature module correctly in the base.
Does the power module have sufficient capacity?	Calculate power consumption rates of the modules and review system constitution.
Mew, replaced temperature module works correctly.	Turn power ON and OFF again. If the problem persists, the module may have problem. Contact nearest dealer.

10.2.2 ALM LED is ON

Checklist	Action
Does the input value exceed the value entered in the input alarm?	In the temperature controller module software package, check [Alarm Status] to take countermeasures.
Does the output value exceed the value entered in the output alarm?	In the temperature controller module software package, check [Alarm Status] to take countermeasures.

10.2.3 RUN LED flashes at 1 second intervals

Checklist	Action
Is there any parameter setting out of the allowable range?	In the temperature controller module software package, check error code in the [Operation Error] of the [Operation Information] to take countermeasures.

10.2.4 A/D Converted value is not changed

Checklist	Action
Is the loop whose A/D conversion value was not changed was set to [Operation]?	If it is set to [Stop], change it to [Operation].
Is the loop input terminal wiring correct?	See 3.2 for correct wiring.

10.2.5 The digital output is not in relation with the analog input value.

Checklist	Action
Are the types of the analog inputs to the loops in accordance with the designated types?	Check the analog input types. Correct it if necessary.
Is the loop input terminal wiring correct?	See 3.2 for correct wiring.
Does the environment provide noise?	Process with weighted average method or moving average method.

10.2.6 Out of Control.

Checklist	Action
Is the loop set in [Operation]?	If it is set to [Stop], change it to [Operation].
Is the designated [Control Type] appropriate?	Of the [PID], [CASCADE] or [ON/OFF], check that desired control type is set up.
Are the PID [control coefficients] appropriately set up?	If the set up control coefficient is inappropriate, calculate the coefficient through [Auto Tuning].
Is the wiring of the control output terminal correct?	See 3.2.2 to check that heating/cooling output terminals are correctly connected with respective line.

10.2.7 Checking Temperature Controller Module Status with Software Package

Using the [Module Information] function of the software package, name, OS version, date of OS, and status of the module can be checked.

(1) Procedure

[Online] -> [Module Information]

(2) Module Information

(a) Module Name: shows the information of the present module.

(b) OS version: shows the OS version of the temperature controller module.

(c) OS date: shows the date of the OS release of the temperature controller module.

(e) Module status: shows present error code. (see Table 9.1 for error codes)

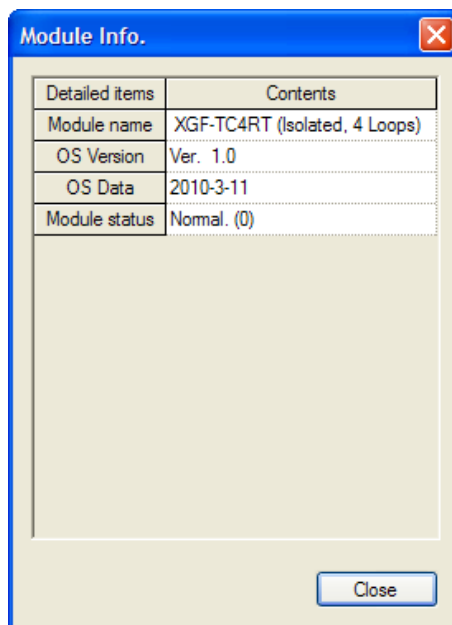
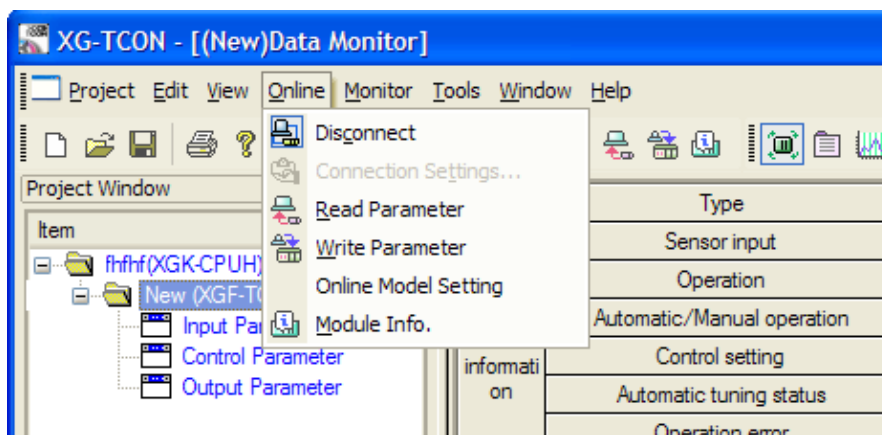

Appendix 1 Terminology

Describes terminologies used in this manual

Terminology related with control

- Channel and loop: XGF-TC4RT module is having 4 inputs and 4 outputs and IO's unit is called a channel. A loop means one PID operation and IO related with that PID operation. Generally, a loop is composed of one PID, one input and one output and specially, for heating/cooling simultaneous output, one input, one PID, two outputs composes one loop. Since XGT-TC4RT supports 4 channels of input and output and 4 PID operations, up to 4 loops are available. In case of heating/cooling simultaneous output, a loop occupies 2 outputs so up to 2 loops are available.
- Input and PV: Input is a signal coming form RTD sensor. Current temperature is changed into an electrical signal by sensor and this signal flows into the module. And then that changes into a number through A/D conversion. XGF-TC4RT takes the A/D converted number and executes PID operation with that number. So the process converting a temperature into a number is input process. The final number is called PV (PrOcess Value)
- SV (Set-point Value): SV means a number indicating a target temperature. This value is a A/D converted value of target temperature like a above PV
- EV (Error Value): EV means difference between a PV and a SV. If EV is big, that means it will take long time for a PV to reach a SV value. And if EV is small, that means PV is similar with SV. And if EV is 0, that means PV is same as SV.
- Control cycle Ts: It means a cycle refreshing control output through an input and PID operation in the loop.
- Proportional coefficient Kp and P operation: Kp is first coefficient of PID operation. It affects all operations, P operation, I operation and D operation. P operation outputs the EV multiplied by Kp.
- Integral coefficient Ti and I operation: Ti is second coefficient of PID and affects I operation. When I operation, integral calculus is executed. At this time, since PLC is a digital device, discrete integral is executed. It makes the increment by dividing a change of EV with Ti and multiplying Kp. So the smaller Ti is and the larger Kp, the larger I operation results.
- Differential coefficient Td and D operation: Td is third coefficient of PID and affects D operation. D operation yields a result by multiplying Td and Kp to a change of EV. This value, when PV is rising, reduces output and when PV is falling, increases output. This causes high stability of the system. D operation acts reversely with P, I operation. So excessive Td value can disturb the entire operation
- Output and MV, control BIAS: MV is result of PID operation and is yielded by adding P operation, I operation, D operation and control BIAS value together. MV is changed into output through some process (Max Min limit and change limit) and output is changed into time and drives output TR. The above SV and PV use same temperature value but MV is a signal transmitted to a heater and it has different unit with SV and PV.
- Auto-tuning SV and auto-tuning HYS: When using auto-tuning, you can another SV. But generally, auto-tuning SV is same as SV. When auto-tuning, it outputs maximum value and determines whether PV exceeds the auto-tuning SV. At this time, if there is a noise, it makes that hard. To solve this problem, when rising, it compares PV with [Auto-tuning SV+Auto-tuning HYS] and when falling, it compares PV with [Auto-tuning – Auto-tuning HYS]
- SV upper/lower limit: When SV changes frequently, it is used to prevent from invalid input.

- PV rising/falling tracking: When EV is large, to prevent excessive output, it limits SV value used in operation to [PV+PV rising tracking] ~ [PV-PV falling tracking].
- Control type: PID or ON/OFF control available
- ON/OFF control and HYS: ON/OFF control (based on heating output) turns the TR on when PV is smaller than SV and turns the TR off when PV is larger than SV. At this time, to ignore variation of PV by sensor noise, you can set HYS value. When PV's rising, it compares PV with [SV+ON/OFF HYS] and when falling, it compares PV with [SV-ON/OFF HYS]
- Forward/reversion division: The system where if output increases, PV increase is defined as forward action system. Reverse system is defined as reverse action system
- Deadband (DB): If PV comes in $SV \pm DB$ range, it considers EV is 0
- Anti-windup: If EV is large with one direction, integral result increases excessively, which causes it takes long time to recover integral result when entering stable status. If you set anti-windup, it stops integral operation for a while under proportional operation saturation condition (When EV is quite large)
- No impulse manual escape: when automatic/manual conversion, if manual operation changes into automatic operation, since there is no accumulated integral result, it may cause impulse. If you use "No impulse manual escape", XGF-TC4RT saves the integral result at the manual operation and uses that integral result when escaping from the manual mode.

Terminology related with output

- Heating/cooling selection: selects output type by heating or cooling system. In case of forward action, heating output operates to increase MV when heating is needed and cooling output operates to increase MV when cooling is needed. For [Heating] and [Cooling], it outputs through the output channel which is same as each loop number. For [Heating/Cooling], odd number loop's (Loop number +1) output is prohibited and it is used as cooling output channel of even loop
- Cooling output ratio: in case characteristic of cooling system is quite different with that of heating system, you can set the ration of heating to output.
- PWM cycle: in case output is PWM type, it specified a change cycle of output. This cycle is different with control cycle (Ts) and means total time of rising + falling PWM signal
- Output upper/lower limit: it is used to specify the range of output.
- Output change limit: you can set a limit on the output varying every control cycle.
- Output reference: You can set the output BIAS. This value is added to output value.
- Manual output value: when changing into a manual operation mode, this value is outputted through output channel
- Abnormal condition output: when PLC and the module are abnormal, this value is outputted.
- Output alarm: if heating/cooling output value is larger than the upper limit or smaller than the lower limit, alarm bit will be set. Upper limit alarm is canceled when output is falling under the output alarm value - HYS value and lower limit alarm is canceled when output is rising over output alarm value + HYS value.

Terminology related with input

- Input type: Pt100, jPt100, Pt1000 are available for RTD sensor. And it can get an external input. The external input means taking a digital value in the PLC as input. Put the input value in the U area and select [Ext. input] at the command window.
- Disconnection detection: detects the disconnection of input sensor
- Effective input upper/lower limit: when you want to use specific section of sensor range, you can set effective input upper/lower limit
- Scale upper/lower limit: this function is available when you set the input type as voltage or current in the XGF-TC4UD, you can scale the converted value of input signal.
- Input BIAS: When sensor reference is not correct, you can correct it through software.
- Average: if you set the averaging type and averaging value, average of input is used for operation
- Input alarm: if input value is larger than upper limit (or high upper limit) or smaller than lower limit (or low lower limit), alarm bit will be set. Upper limit alarm is canceled when input is falling under input alarm value – HYS and lower limit alarm is canceled when input is rising over input alarm value + HYS

Appendix 2 Dimension

1) Dimension of XGF-TC4RT

Unit: mm

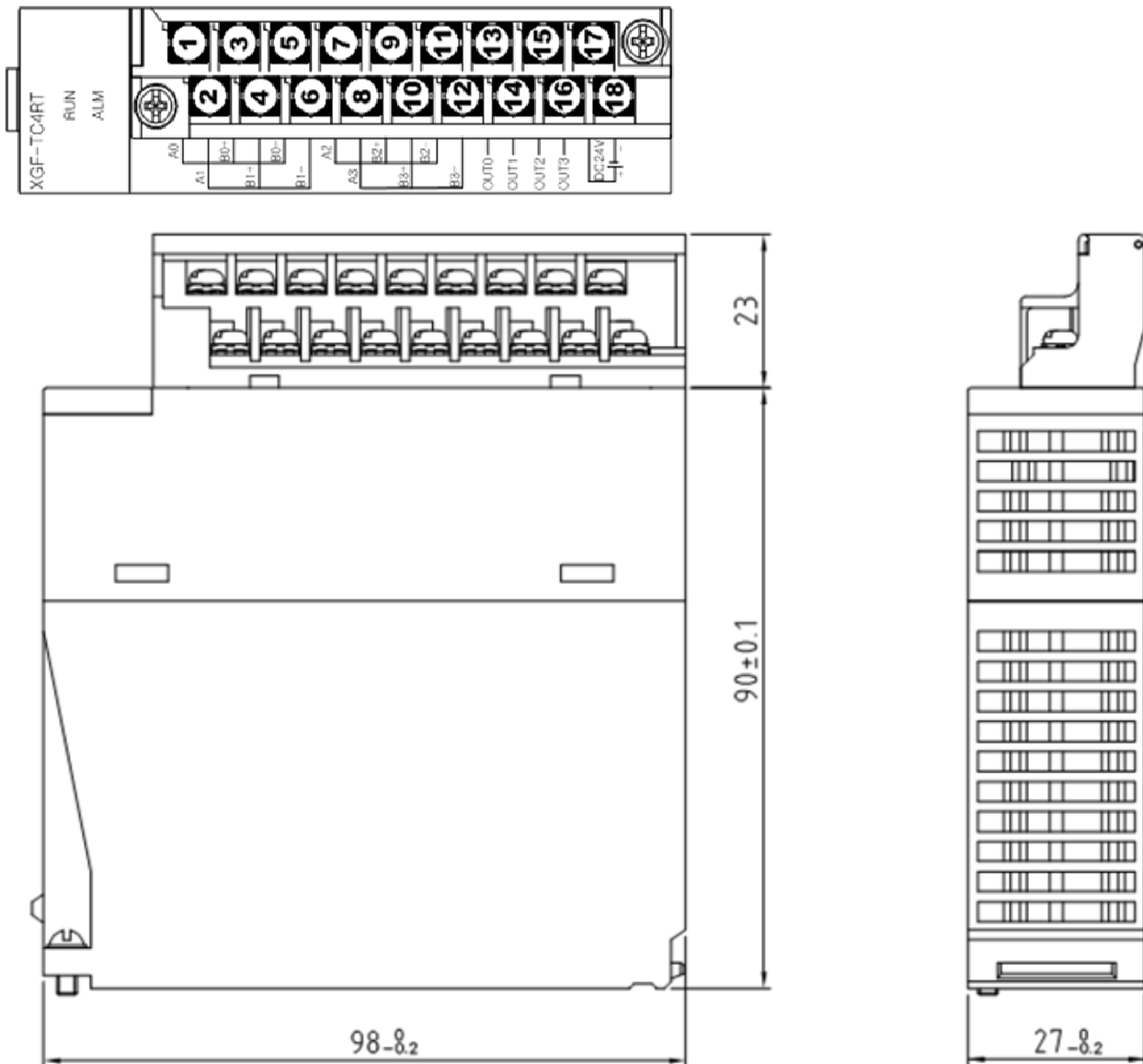

Warranty

1. Warranty Period

The product you purchased will be guaranteed for 18 months from the date of manufacturing.

2. Scope of Warranty

Any trouble or defect occurring for the above-mentioned period will be partially replaced or repaired. However, please note the following cases will be excluded from the scope of warranty.

- (1) Any trouble attributable to unreasonable condition, environment or handling otherwise specified in the manual,
- (2) Any trouble attributable to others' products,
- (3) If the product is modified or repaired in any other place not designated by the company,
- (4) Due to unintended purposes
- (5) Owing to the reasons unexpected at the level of the contemporary science and technology when delivered.
- (6) Not attributable to the company; for instance, natural disasters or fire

3. Since the above warranty is limited to PLC unit only, make sure to use the product considering the safety for system configuration or applications.

Environmental Policy

LS Industrial Systems Co., Ltd supports and observes the environmental policy as below.

Environmental Management

LS Industrial Systems considers the environmental preservation as the preferential management subject and every staff of LS Industrial Systems use the reasonable endeavors for the pleasurable environmental preservation of the earth.

About Disposal

LS Industrial Systems' PLC unit is designed to protect the environment. For the disposal, separate aluminum, iron and synthetic resin (cover) from the product as they are reusable.



**LS values every single customers.
Quality and service come first at LSIS.
Always at your service, standing for our customers.**

<http://eng.lsis.biz>

LS Industrial Systems

10310001123

■ **HEAD OFFICE**

LS tower, Hogye-dong, Dongan-gu, Anyang-si, Gyeonggi-do 1026-6,
Korea <http://eng.lsis.biz>
Tel : (82-2)2034-4870/Fax : 82-2-2034-4648 e-mail : cshwang@lsis.biz

■ **LS Industrial Systems Tokyo Office _ Tokyo, Japan**

Address: 16FL, Higashi-Kan, Akasaka Twin Tower 17-22,
Akasaka.Monato-ku Tokyo 107-8470. Japan
Tel : 81-3-3582-9128/Fax : 81-3-3582-2667 e-mail : jschuna@lsis.biz

■ **LS Industrial Systems(ME) FZE _ Dubai, U.A.E.**

Address : Jafza View Tower Lob 19, Room 205 Along Sheikh Zayed
Road Jebel Aali Free Zone Dubai, United Arab Emirates
Tel : 971-4-886-5360/Fax : 971-4-886-5361 e-mail : jungyongl@lsis.biz

■ **LS Industrial Systems Shanghai Office _ Shanghai, China**

Address : Room E-G, 12FL Hiamin Empire Plaza, No.726, West,
Yan'an Road Shanghai 200050, P.R. China e-mail : liyong@lsis.com.cn
Tel : 86-21-5237-9977(609)/Fax : 89-21-5237-7189

■ **LS Industrial Systems Beijing Office _ Beijing, China**

Address : B-Tower 17FL, Beijing Global Trade Center B/D, No. 36,
East BeisanHuan-Road, DongCheng-District, Beijing 100013, P.R. China
Tel : 86-10-5825-6027(666)/Fax : 86-10-5825-6028 e-mail : xunmj@lsis.com.cn

■ **LS Industrial Systems Guangzhou Office _ Guangzhou, China**

Address : Room 1403.14FL, New Poly Tower,
2 Zhongshan Liu Road,Guangzhou,P.R China
Tel : 86-20-8328-6754/Fax : 86-20-8326-6287 e-mail : chenxs@lsis.com.cn

■ **LS Industrial Systems Chengdu Office _ Chengdu, China**

Address : 12FL, Guodong Buiding, No.52 Jindun
Road Chengdu.610041, P.R. China
Tel : 86-28-8612-9151(9226)/Fax : 86-28-8612-9236 e-mail : comysb@lsis.biz

■ **LS Industrial Systems Qingdao Office _ Qingdao, China**

Address : YinHe Bldg, 402 Room No. 2P Shandong Road,
Qingdao-City,Shandong-province 266071, P.R. China
Tel : 86-532-8501-6068/Fax : 86-532-8501-6057 e-mail : wangzy@lsis.com.cn

■ **LS Industrial Systems Europe B.V. , Netherlands**

Address : 1st Floor, Tupolevlaan 48, 1119NZ, Schiphol-Rijk, The Netherlands
Tel : +31 (0)20 654 1420/Fax : +31 (0)20 654 1429 e-mail : junshickp@lsis.biz

■ **Wuxi LS Industrial Systems Co., Ltd _ Wuxi, China**

Address : 102-A, National High & New Tech Industrial Development Area,
Wuxi, Jiangsu, 214028, P.R. China
Tel : 86-510-8534-6666/Fax : 86-510-8534-4078 e-mail : caidx@lsis.com.cn

■ **Dalian LS Industrial Systems Co., Ltd. _ Dalian, China**

Address : No. 15, Liaohexi 3-Road, Economic and Technical Development zone,
Dalian 116600, China
Tel : 86-411-273-7777/Fax : 86-411-8730-7560 e-mail : cuibx@lsis.com.cn

※ LS Industrial Systems constantly endeavors to improve its product so that information in this manual is subject to change without notice.

© LS Industrial Systems Co., Ltd 2010 All Rights Reserved.

2010. 9