

1 Safety information



WARNING

Follow the instructions

The mechanical and electrical installation instructions must be adhered to. Any questions or doubt should be referred to the supplier of the equipment. It is the responsibility of the owner or user to ensure that the installation of the drive and any external option unit, and the way in which they are operated and maintained, comply with the requirements of the Health and Safety at Work Act in the United Kingdom or applicable legislation and regulations and codes of practice in the country in which the equipment is used.



WARNING

Competence of the installer



The drive must be installed by qualified personnel who are familiar with the requirements for safety and EMC. The installer is responsible for ensuring that the end product or system complies with all the relevant laws in the country where it is to be used.

2 Introduction

This document covers through-panel mounting instructions for Unidrive M600, M700 and M800 Size 5 drives. The standard drive is rated to IP20 pollution degree 2 (dry, non-conductive contamination only, NEMA 1), however it is possible to configure the device to achieve IP65 rating (NEMA 12). This is done by sealing the heat sink vents at the rear of the heatsink by installing the high IP inserts as illustrated in Figure 3-1. Some current derating is required, and reference should be made to the drive User Guide for current derating information.

The following items are supplied in the kit bag:

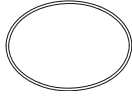
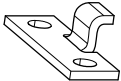
Table 2-1 Contents of the bag (CT Part Number: 3470-0067-03)

Description	Image	Qty
Through panel mounting gasket		x 1
Through panel securing brackets		x 2
High IP inserts		x 2
Through panel mounting installation sheet		x 1

The following items are included in the kit boxes 3470-0071 and 3470-0072, both of which are supplied with the drive.

Table 2-2 Additional items required

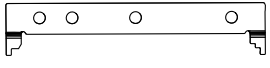
Description	Image	Qty
Frame 5 mounting brackets		x 2

3 Instructions

3.1 Installing the high IP inserts

Figure 3-1 Installing the high IP inserts

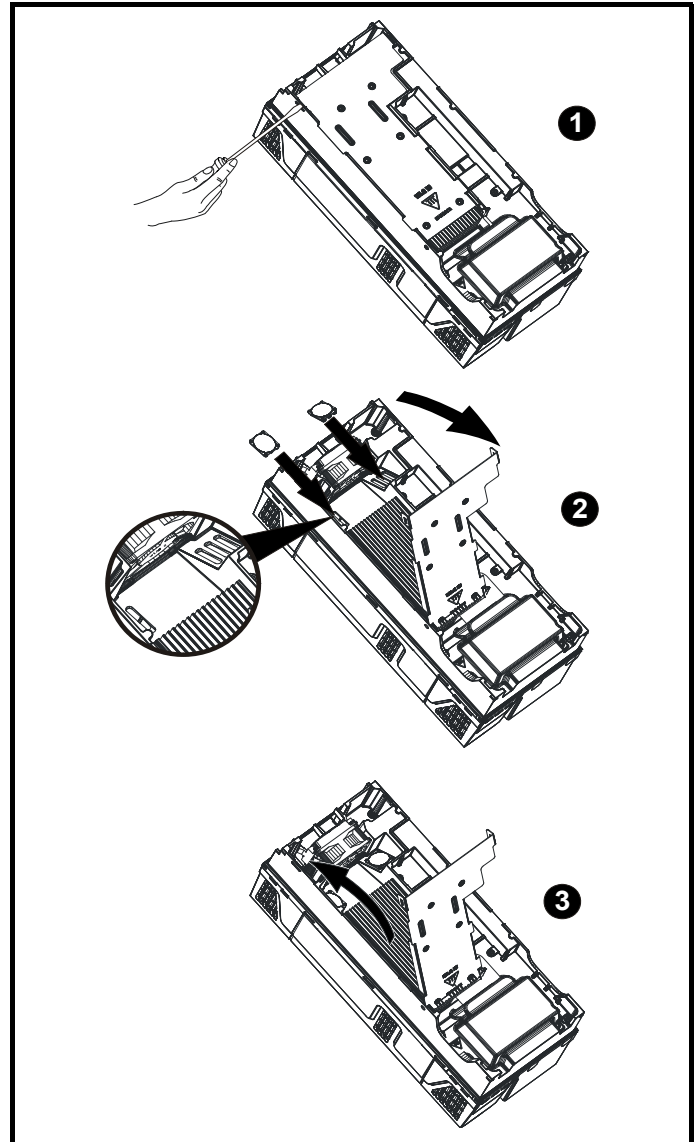

1. To install the high IP inserts, first unclip the baffle plate using a flat bladed screwdriver inserted under the slot as shown in Figure 3-1 (1).
2. Pull the hinged baffle plate down to expose the ventilation holes. Install the two high IP inserts into the ventilation holes in the heatsink (2). Ensure the high IP inserts are fully installed by pressing them firmly into place.
3. Close the hinged baffle plate by rotating it upwards until the clips on the baffle plate are secure within the slots in the drive chassis as shown in (3).

3.2 Preparing the backplate

Figure 3-2 Backplate mounting detail

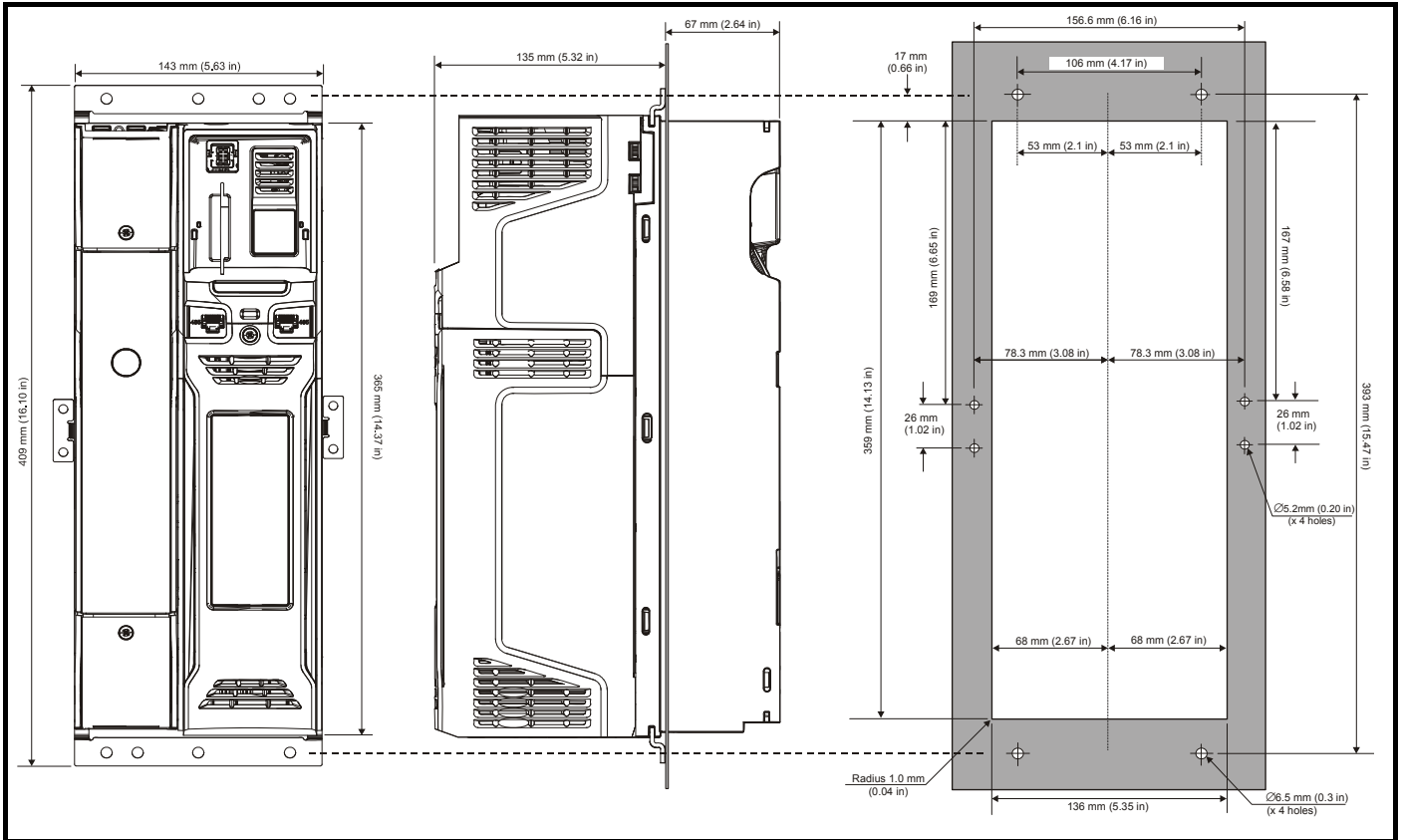

Prepare the backplate in accordance with the mounting dimensions shown in Figure 3-2.

3.3 Preparing for installation

Figure 3-3 Installing the gasket

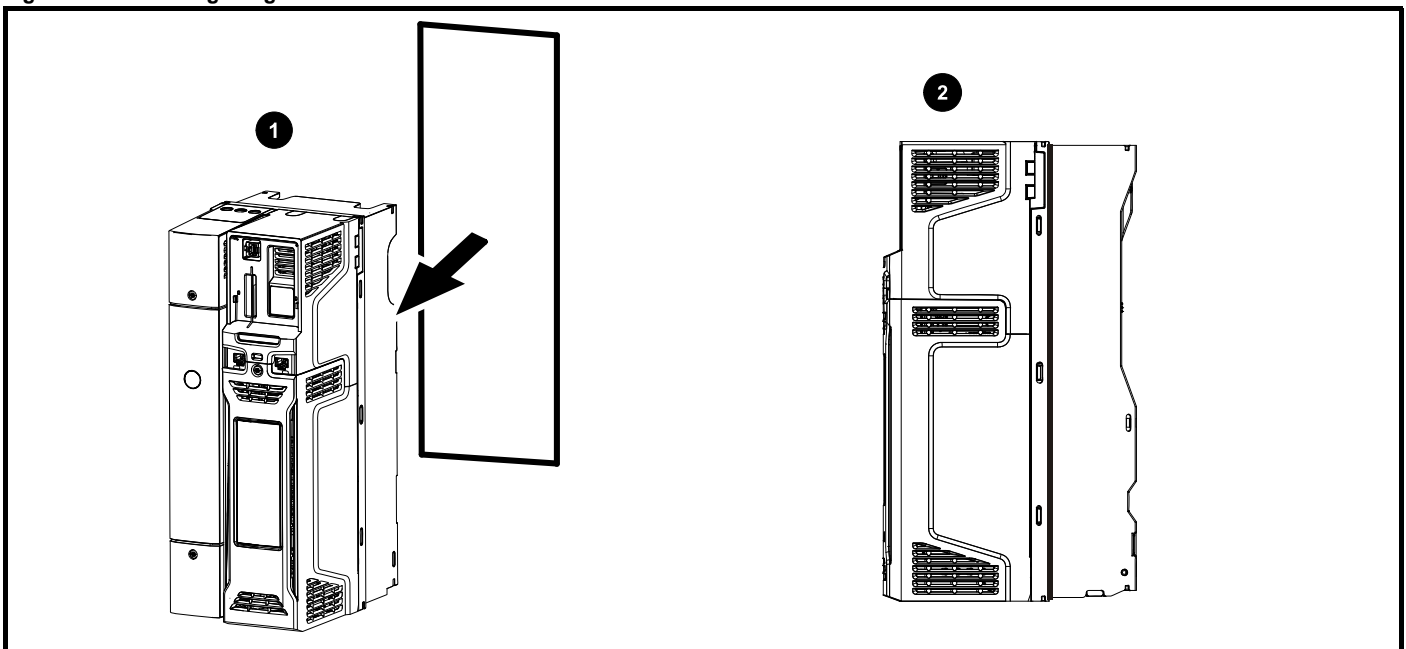

1. Install the main gasket with the kit provided as shown (1).
2. The image on the right shows the assembled drive and gasket (2).

3.4 Through hole mounting installation

Figure 3-4 Position the drive through the backplate

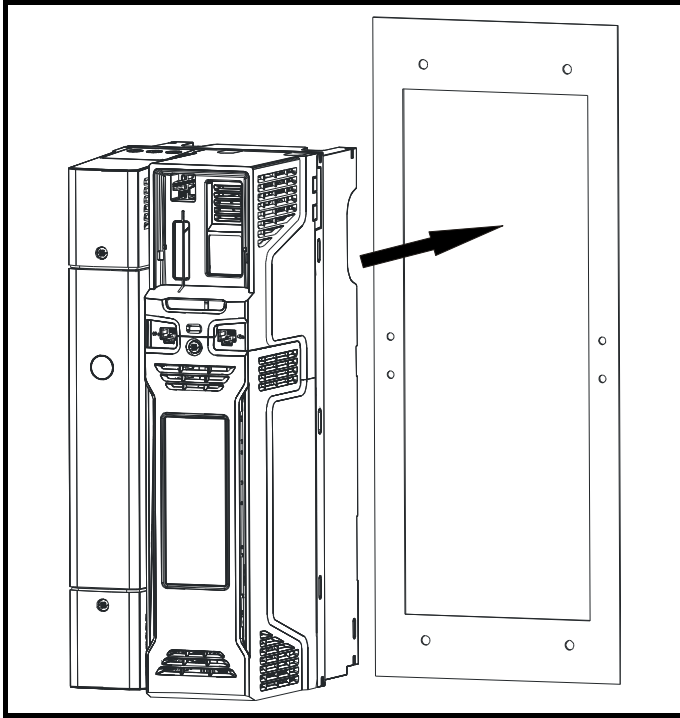

Insert the drive through the backplate.

Figure 3-5 Inserting the drive through the backplate and securing to the backplate

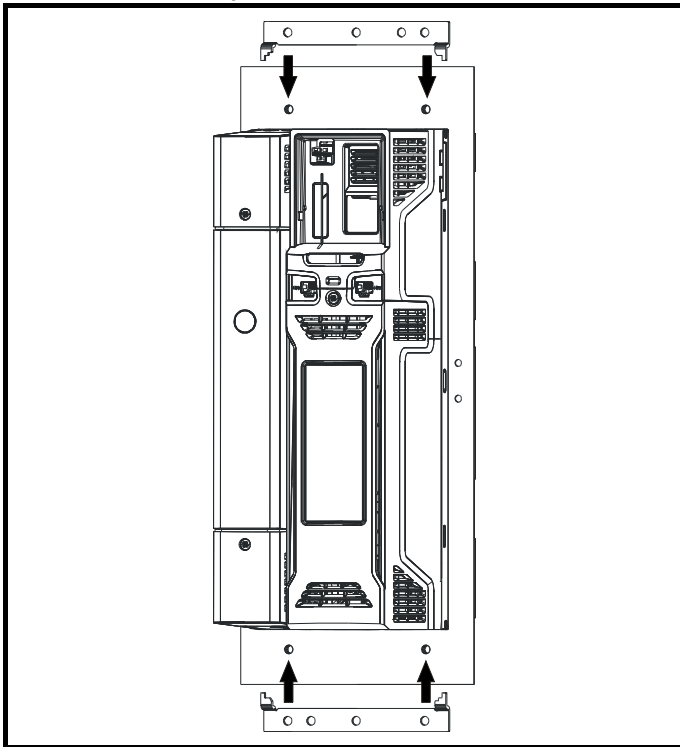

Mount the upper and lower brackets using suitable M6 fasteners.

Figure 3-6 Securing the drive mounting brackets

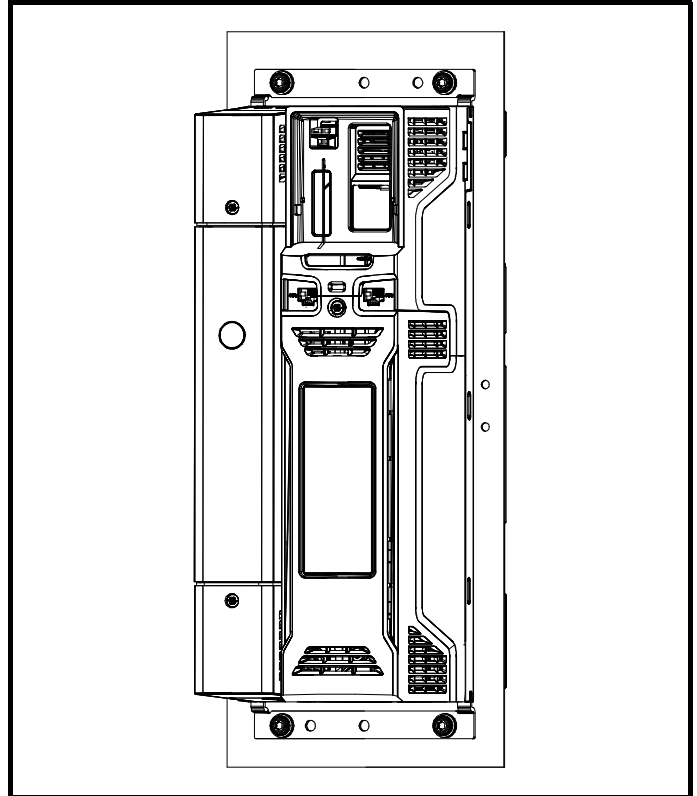

Ensure the M6 fasteners are fully secured at the top and bottom of the mounting plate before proceeding further.

Figure 3-7 Installing the through panel mounting brackets

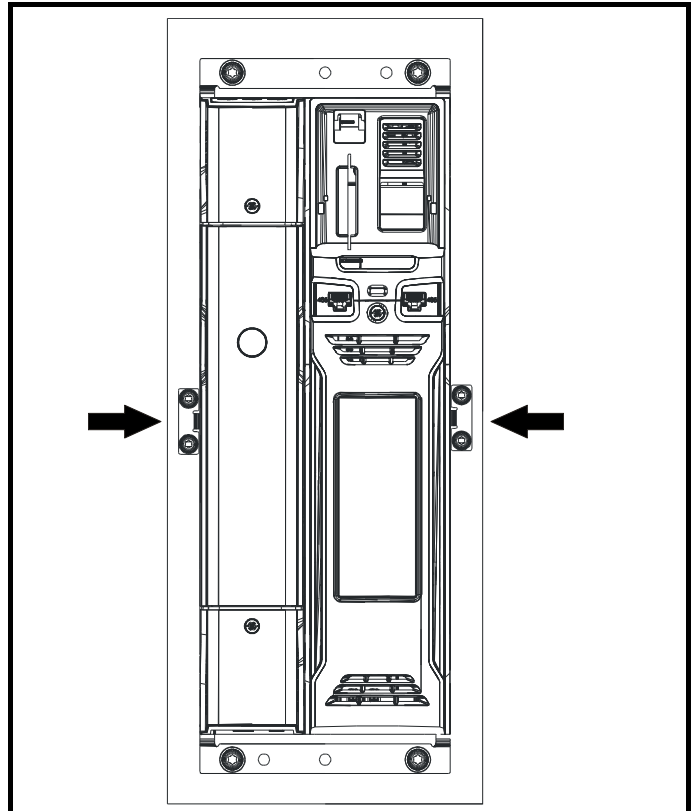

Install the through panel securing brackets (x2) into the drive chassis, and secure them to the backplate using suitable M5 fasteners. Ensure that the gasket does not become trapped under the mounting brackets before fully tightening the M5 fasteners.